

Fuel Lube Truck Off Road Articulated Schematics

2187-1045 COLEMAN TRUCK SERIAL 100980 DRAWING NOTES.....	Page 2
2187-1045 COLEMAN TRUCK SERIAL 100980 PANEL WIRING LIGHTS.....	Page 3
2187-1045 COLEMAN TRUCK SERIAL 100980 EXTERNAL WIRING LIGHTS	Page 4
2187-1045 COLEMAN TRUCK SERIAL 100980 PANEL WIRING FILL LIGHTS & FLOW LINE MONITOR.....	Page 5
2187-1045 COLEMAN TRUCK SERIAL 100980 LEVEL SENSOR WIRING.....	Page 6
2187-1045 COLEMAN TRUCK SERIAL 100980 PANEL WIRING PRODUCTS.....	Page 7
2187-1045 COLEMAN TRUCK SERIAL 100980 EXTERNAL WIRING PRODUCTS.....	Page 8
2187-1045 COLEMAN TRUCK SERIAL 100980 PANEL COMPRESSOR, COMPT LIGHTS & IGN SIGNAL.....	Page 9
2187-1045 COLEMAN TRUCK SERIAL 100980 PANEL WIRING FOR COMPT HEATING.....	Page 10
2187-1045 COLEMAN TRUCK SERIAL 100980 PANEL IGN WIRING.....	Page 11
2187-1045 COLEMAN TRUCK SERIAL 100980 PANEL WIRING CAN BUS/DATA PANEL PRODUCT.....	Page 12
2187-1045 COLEMAN TRUCK SERIAL 100980 HOSE REEL WIRING.....	Page 13
2187-1045 COLEMAN TRUCK SERIAL 100980 HATZ MOTOR WIRING.....	Page 14
2187-1052 DRAWING NOTES.....	Page 15
2187-1052 PANEL WIRING LIGHTS.....	Page 16
2187-1052 EXTERNAL WIRING LIGHTS.....	Page 17
2187-1052 PANEL WIRING FILL LIGHTS & FLOW LINE MONITOR.....	Page 18
2187-1052 LEVEL SENSOR WIRING.....	Page 19
2187-1052 PANEL WIRING PRODUCTS.....	Page 20
2187-1052 EXTERNAL WIRING PRODUCTS.....	Page 21
2187-1052 PANEL WIRING COMPRESSOR, COMPT LIGHTS & IGN SIGNAL.....	Page 22
2187-1052 PANEL WIRING FOR COMPT HEATING.....	Page 23
2187-1052 PANEL IGN WIRING.....	Page 24
2187-1052 PANEL WIRING CAN BUS/DATA PANEL PRODUCT.....	Page 25
2187-1052 HOSE REEL WIRING.....	Page 26
2187-1052 HATZ MOTOR WIRING.....	Page 27



NOTES:

1 END UPFITTER NEEDS TO RUN WIRES TO THE CAB AND INSTALL A SWITCH.

2 IGN WAS SPLICED OFF PIN G TO PROVIDED
IGN TO OUR SOLENOID TO POWER ON CURRY SYSTEM.
SPLICE LOCATION IS LOCATED AT THE CONTROL PANEL.

SHEET REFERENCE:

SHEET 1 - NOTES SHEET

SHEET 2 - ELECTRICAL PANEL WIRING FOR LIGHTS

SHEET 3 - EXTERIOR WIRING FOR LIGHTS

SHEET 4 - ELECTRICAL PANEL WIRING FOR FILL/EMPTY LIGHTS AND FLOW LINE MONITOR

SHEET 5 - LEVEL SENSOR WIRING

SHEET 6 - ELECTRICAL PANEL WIRING FOR PRODUCTS / GREASE / HYD COOLER

SHEET 7 - EXTERIOR WIRING FOR PRODUCTS / GREASE / HYD COOLER

SHEET 8 - ELECTRICAL PANEL WIRING FOR COMPRESSOR / W/O

ANTI / DEF / COMPT LIGHTS AND IGN SIGNAL FROM CONTROL PANEL

SHEET 9 - ELECTRICAL PANEL WIRING FOR COMPT HEATING WIRING

SHEET 10 - IGN WIRING FOR ELECTRICAL PANEL

SHEET 11 - ELECTRICAL PANEL WIRING FOR CAN BUS/DATA PANEL PRODUCT

SHEET 12 - HOSE REEL WIRING

SHEET 13 - HATZ MOTOR WIRING



TITLE: FUEL LUBE SCHEMATIC COLEMAN		DATE 10/29/24
SIZE B	DRAWING NO. 2187-1045	REV 0
SCALE: NTS	DRAWN BY: JS	SHEET 1 OF 13

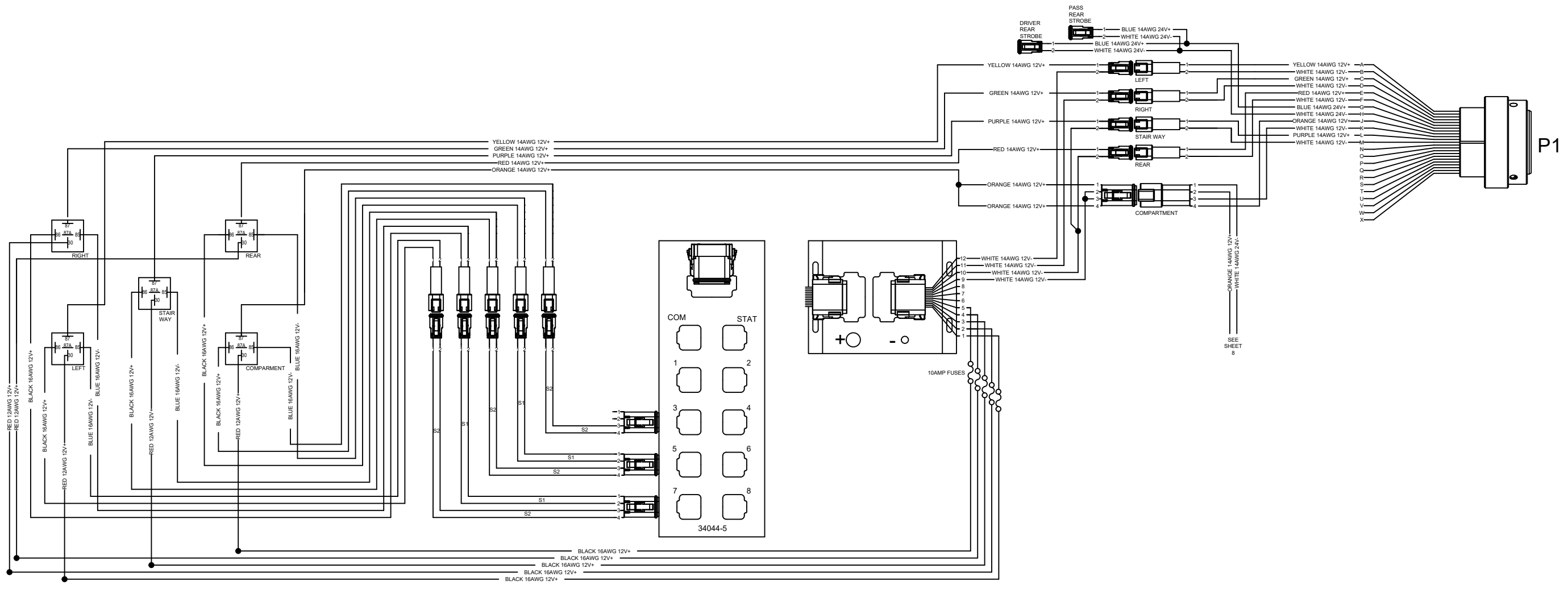

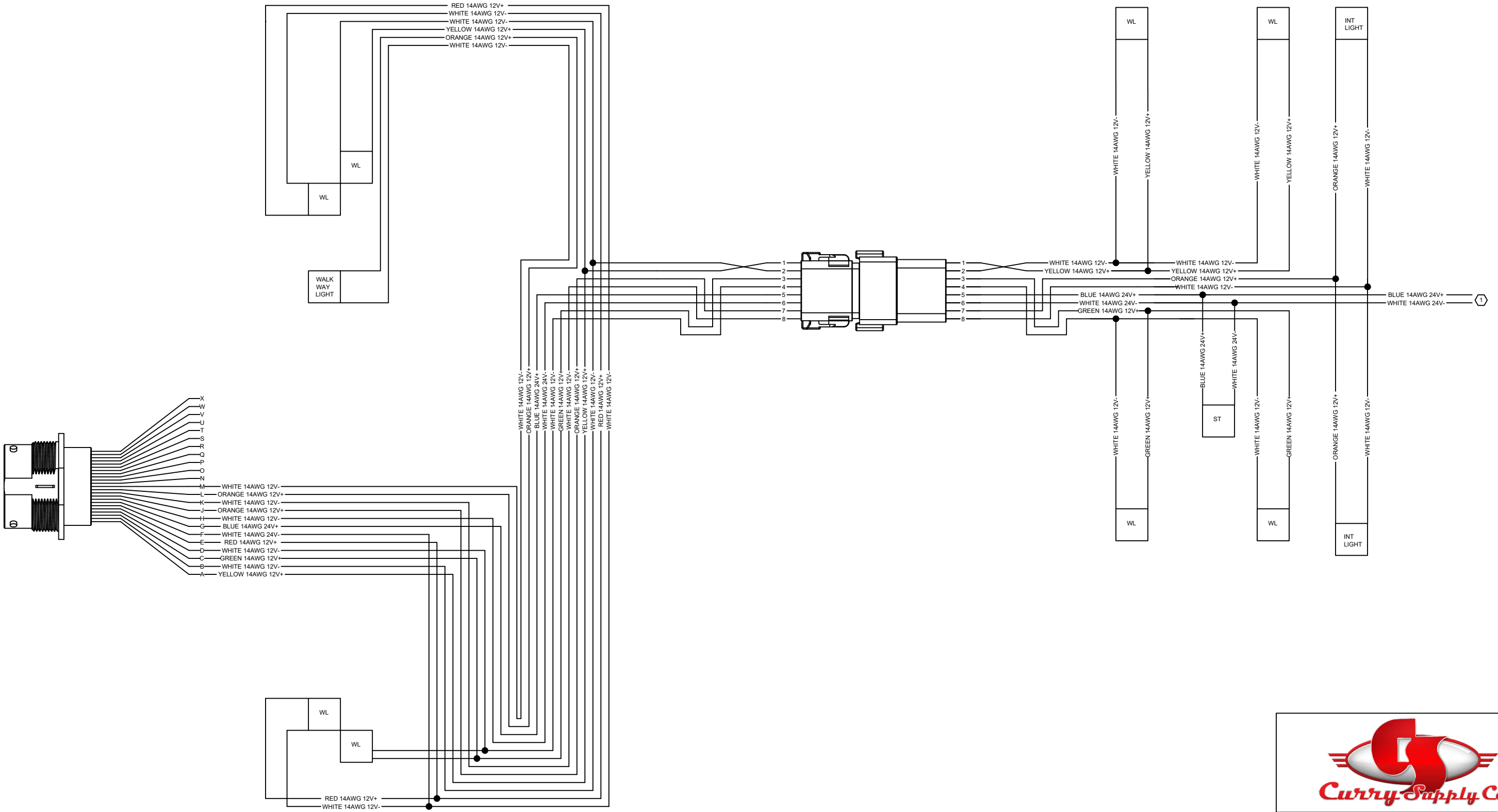

TITLE: FUEL LUBE SCHEMATIC COLEMAN		DATE 10/29/24
SIZE B	DRAWING NO. 2187-1045	REV 0
SCALE: NTS	DRAWN BY: JS	SHEET 2 OF 13

J1

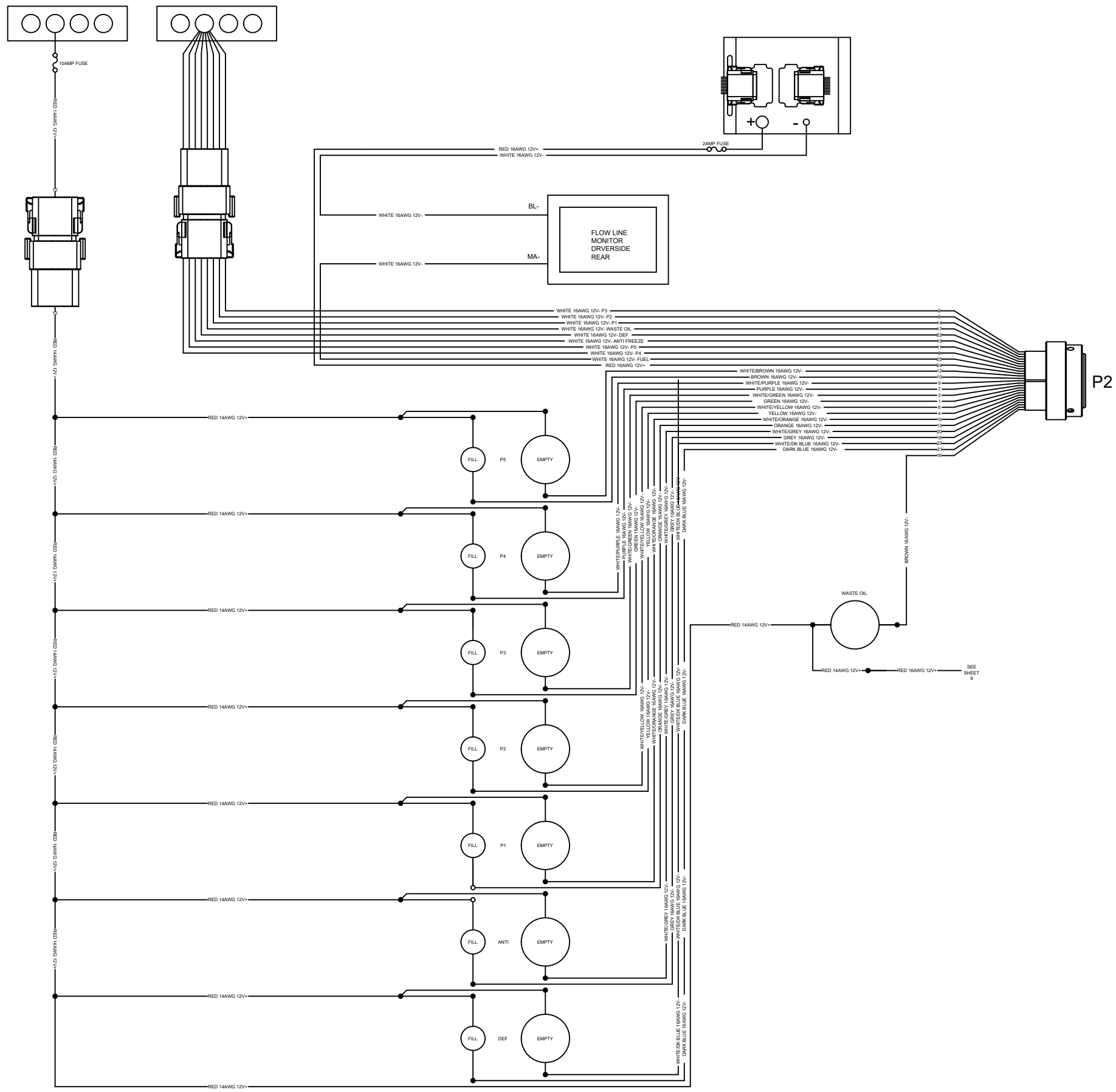

TITLE: FUEL LUBE SCHEMATIC COLEMAN		DATE 10/29/24
SIZE B	DRAWING NO. 2187-1045	REV 0
SCALE: NTS	DRAWN BY: JS	SHEET 3 OF 13



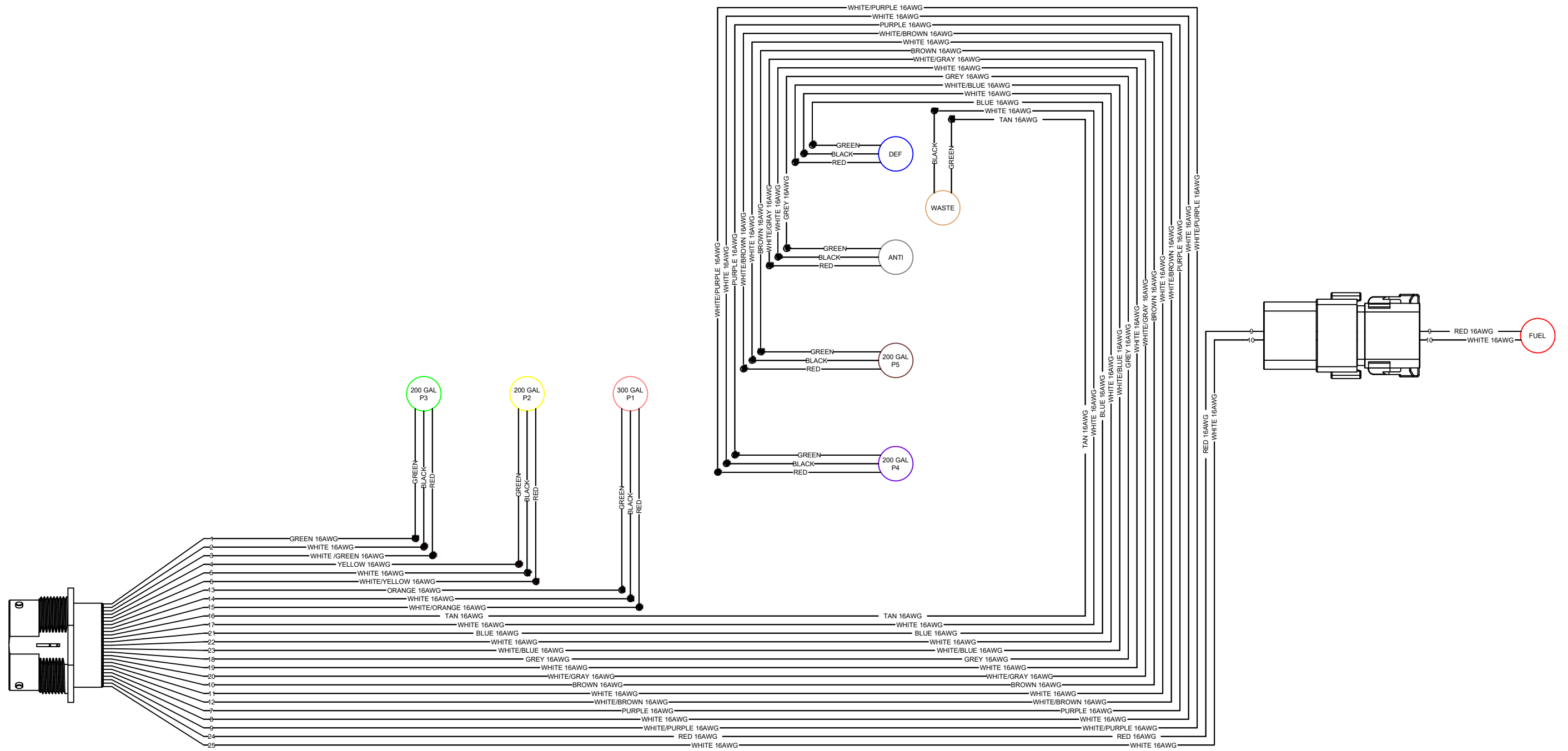

TITLE: FUEL LUBE SCHEMATIC COLEMAN		DATE 10/29/24
SIZE B	DRAWING NO. 2187-1045	REV 0
SCALE: NTS	DRAWN BY: JS	SHEET 4 OF 13

J2

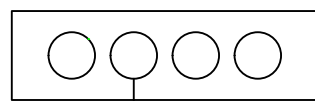

TITLE: FUEL LUBE SCHEMATIC COLEMAN		DATE 10/29/24
SIZE B	DRAWING NO. 2187-1045	REV 0
SCALE: NTS	DRAWN BY: JS	SHEET 5 OF 13



10AMP FUSE

RED 14AWG 12V+

RED 14AWG 12V+

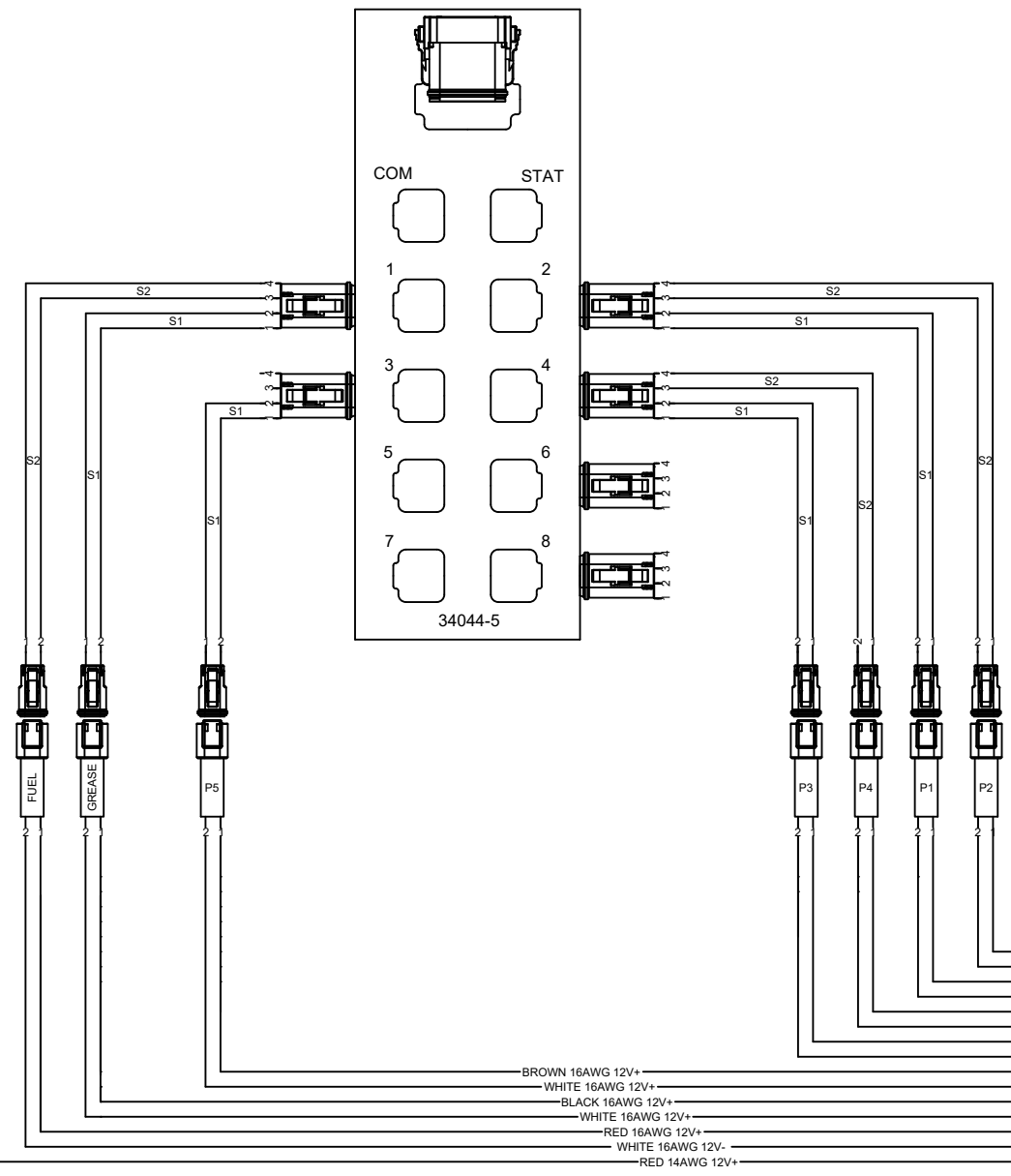

- YELLOW 16AWG 12V+ 3
- WHITE 16AWG 12V- 4
- ORANGE 16AWG 12V+ 9
- WHITE 16AWG 12V- 10
- PURPLE 16AWG 12V+ 5
- WHITE 16AWG 12V- 6
- GREEN 16AWG 12V+ 1
- WHITE 16AWG 12V- 2
- BROWN 16AWG 12V+ 7
- WHITE 16AWG 12V- 8
- BLACK 16AWG 12V+ 13
- WHITE 16AWG 12V- 14
- RED 16AWG 12V+ 11
- WHITE 16AWG 12V- 12
- RED 14AWG 12V+ 15

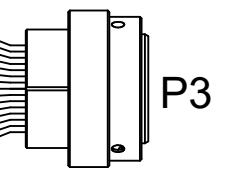

TITLE: FUEL LUBE SCHEMATIC COLEMAN		DATE 10/29/24
SIZE B	DRAWING NO. 2187-1045	REV 0
SCALE: NTS	DRAWN BY: JS	SHEET 6 OF 13

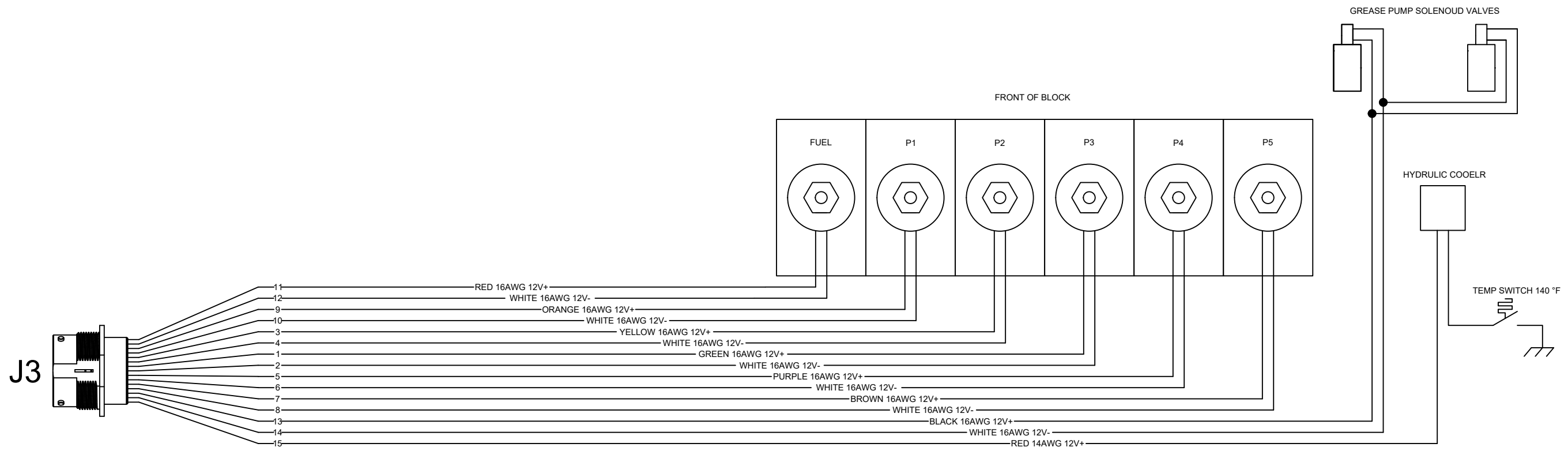

TITLE: FUEL LUBE SCHEMATIC COLEMAN		DATE 10/29/24
SIZE B	DRAWING NO. 2187-1045	REV 0
SCALE: NTS	DRAWN BY: JS	SHEET 7 OF 13

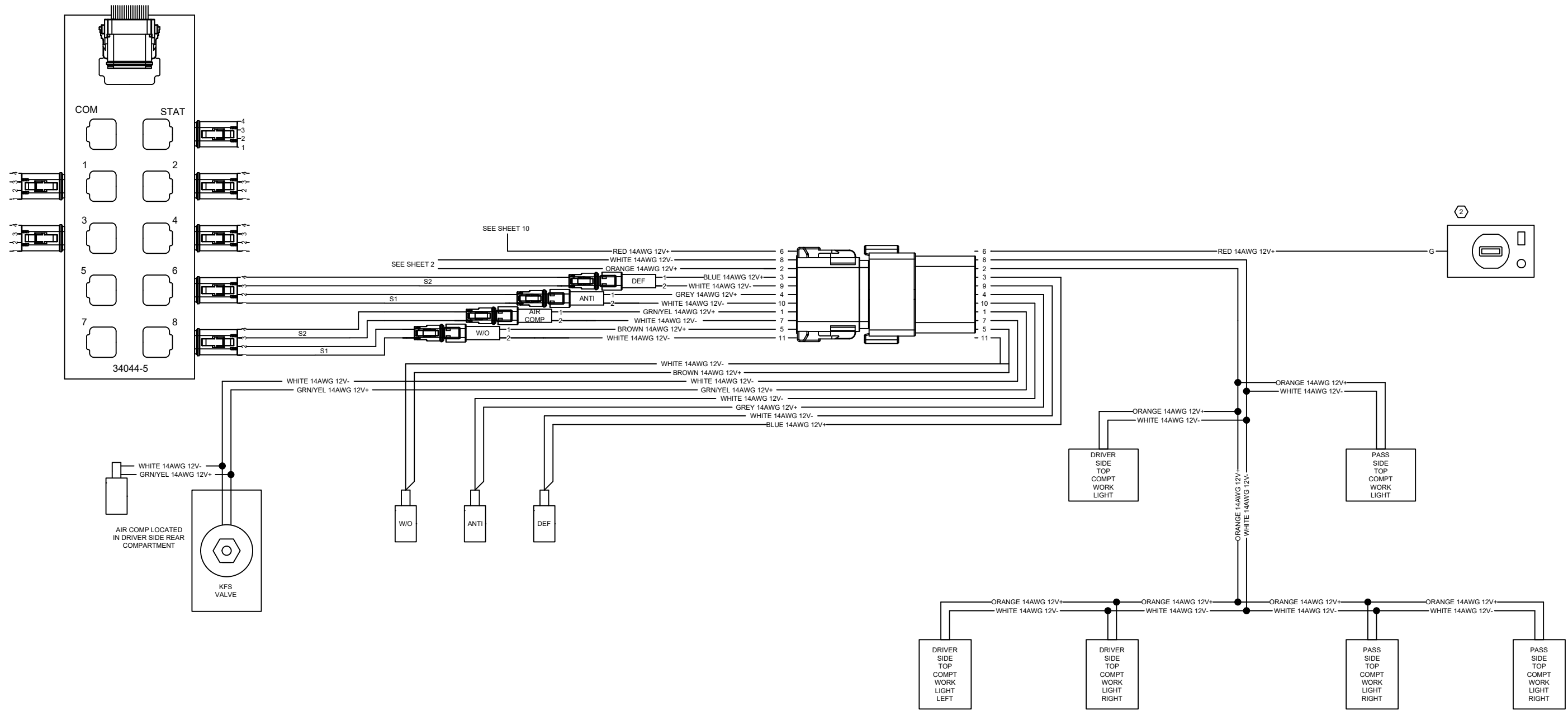

TITLE: FUEL LUBE SCHEMATIC COLEMAN		DATE 10/29/24
SIZE B	DRAWING NO. 2187-1045	REV 0
SCALE: NTS	DRAWN BY: JS	SHEET 8 OF 13

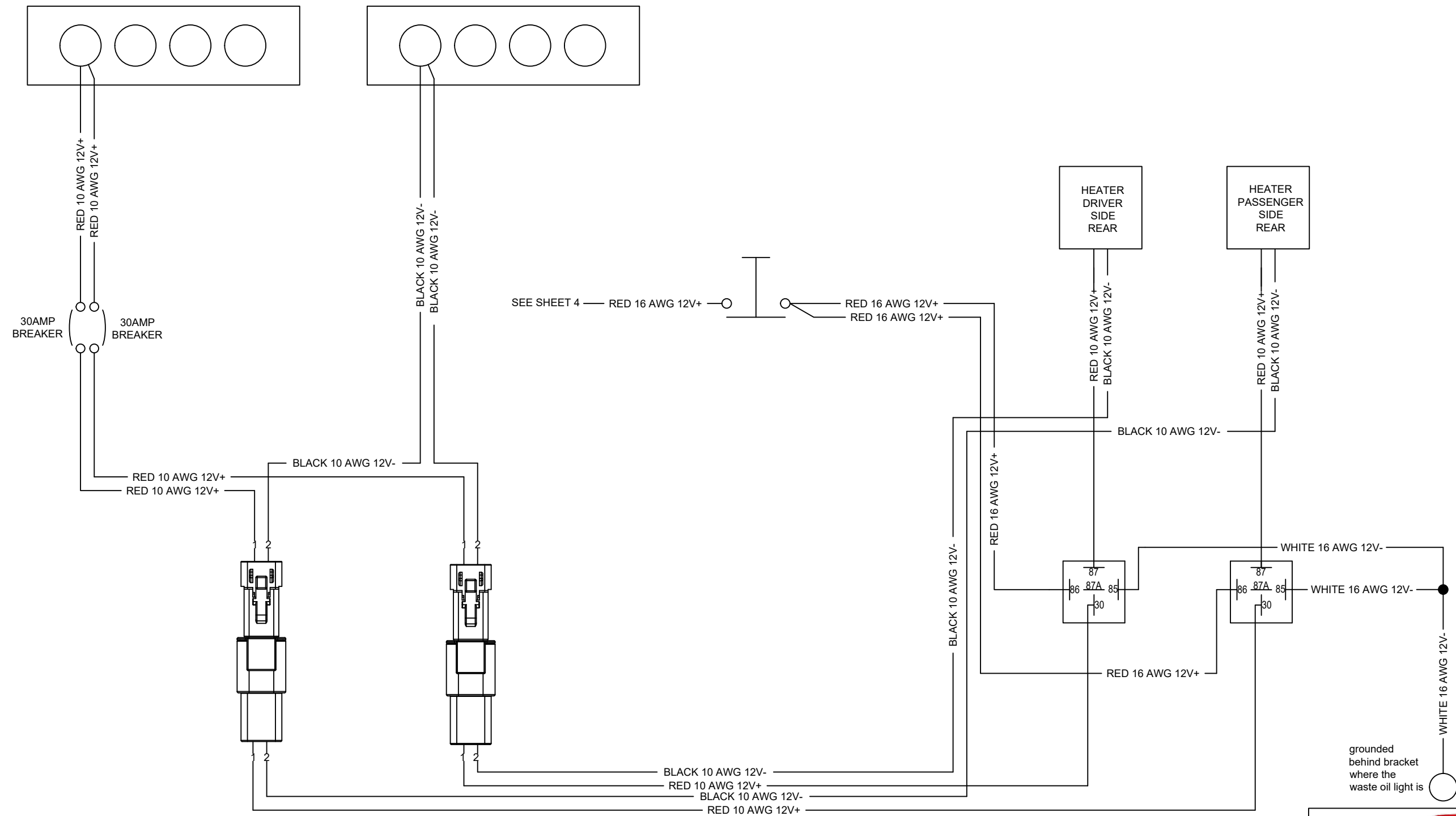

TITLE: FUEL LUBE SCHEMATIC COLEMAN		DATE 10/29/24
SIZE B	DRAWING NO. 2187-1045	REV 0
SCALE: NTS	DRAWN BY: JS	SHEET 9 OF 13

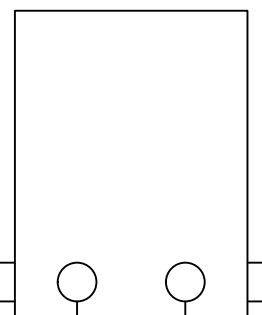
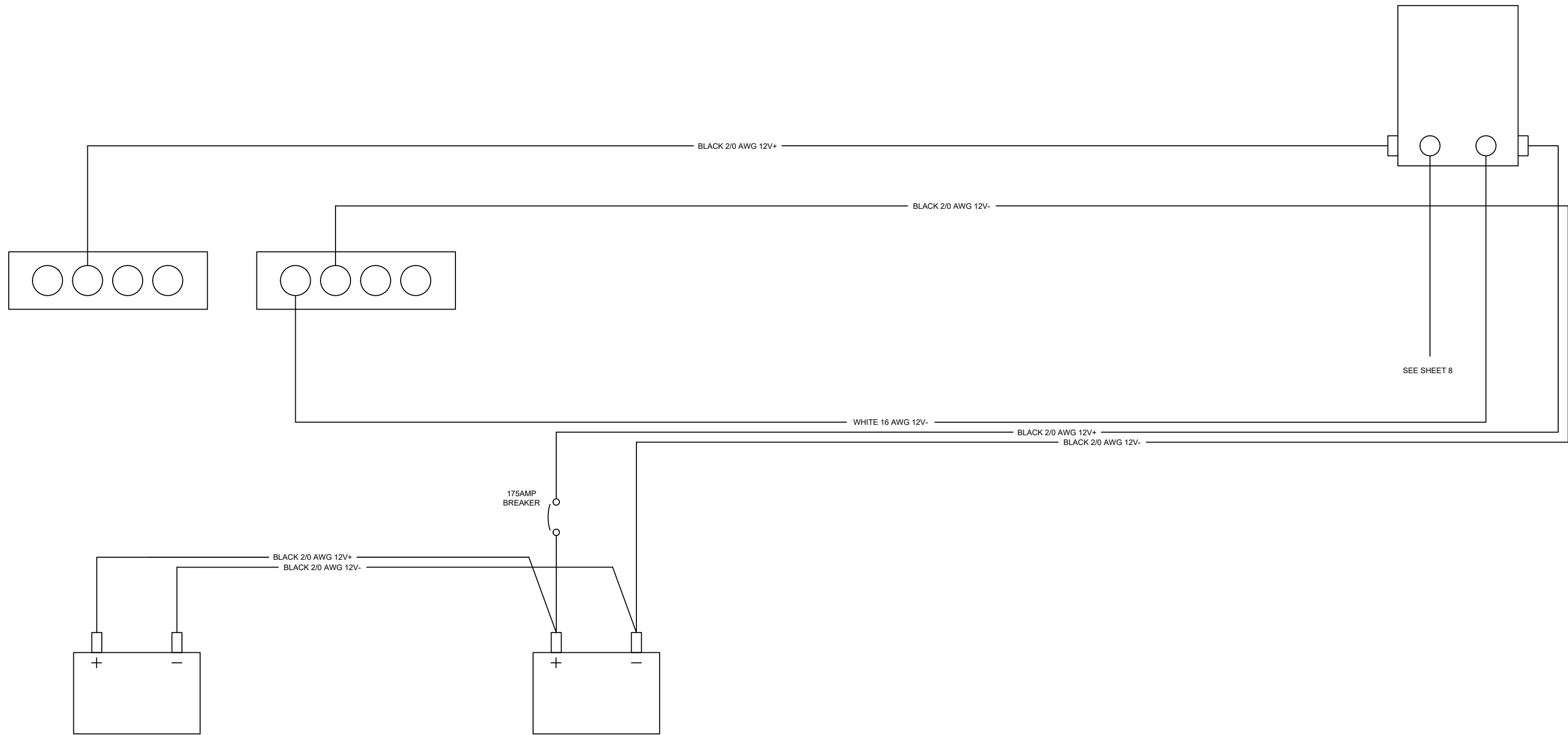

SEE SHEET 8

175AMP
BREAKER

BLACK 2/0 AWG 12V+
BLACK 2/0 AWG 12V-



WHITE 16 AWG 12V-

BLACK 2/0 AWG 12V+

BLACK 2/0 AWG 12V-

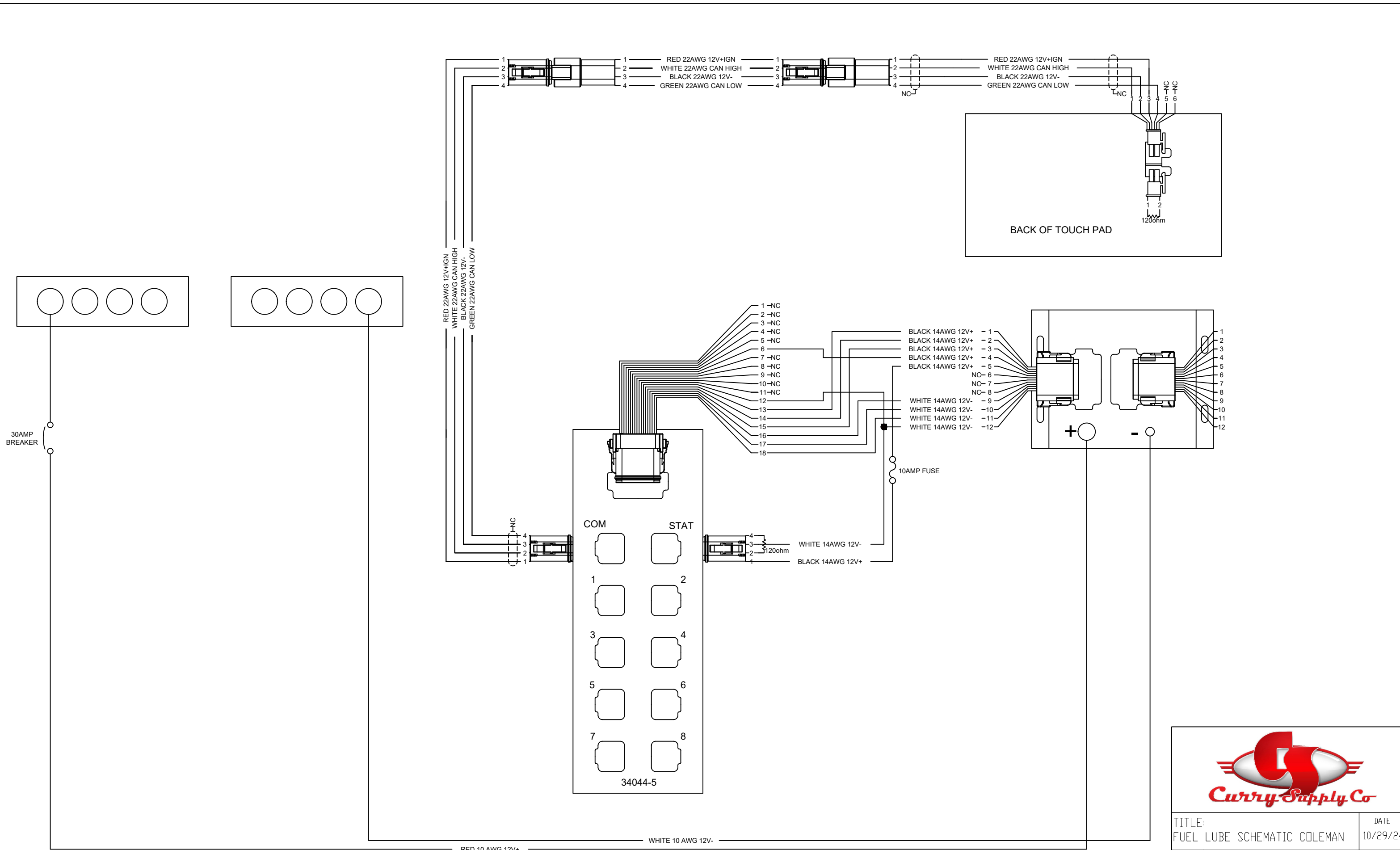

TITLE: FUEL LUBE SCHEMATIC COLEMAN		DATE 10/29/24
SIZE B	DRAWING NO. 2187-1045	REV 0
SCALE: NTS	DRAWN BY: JS	SHEET 10 OF 13

TITLE: FUEL LUBE SCHEMATIC COLEMAN		DATE 10/29/24
SIZE B	DRAWING NO. 2187-1045	REV 0
SCALE: NTS	DRAWN BY: JS	SHEET 11 OF 13

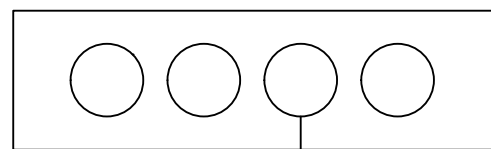
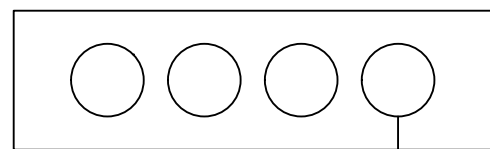

50AMP BREAKER

BLACK 6 AWG 12V+

BLACK 6 AWG 12V-

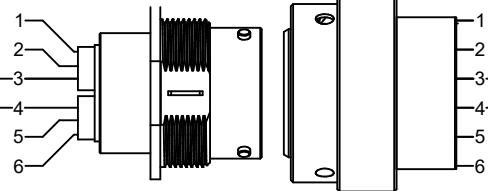

BLACK 6 AWG 12V+

BLACK 6 AWG 12V-

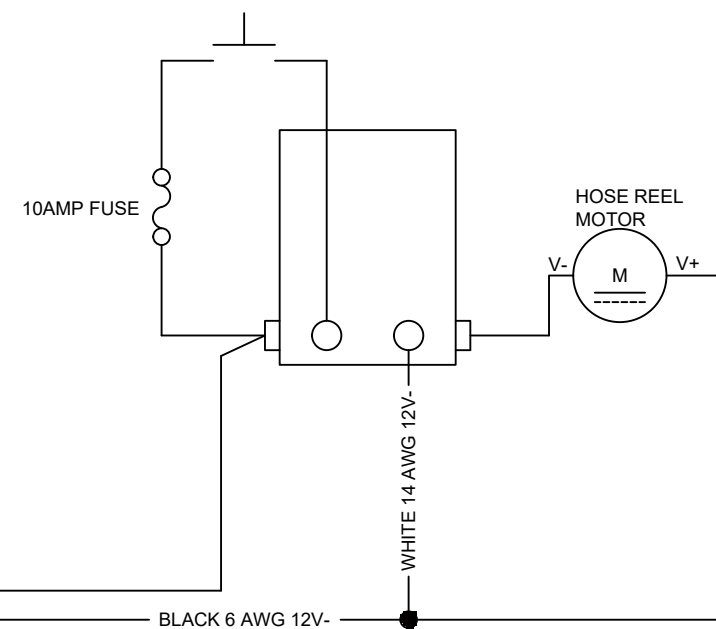

WHITE 14 AWG 12V-



TITLE: FUEL LUBE SCHEMATIC COLEMAN		DATE 10/29/24
SIZE B	DRAWING NO. 2187-1045	REV 0
SCALE: NTS	DRAWN BY: JS	SHEET 12 OF 13

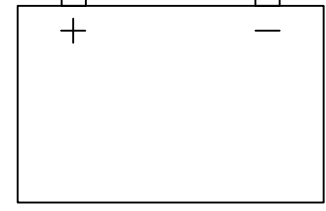
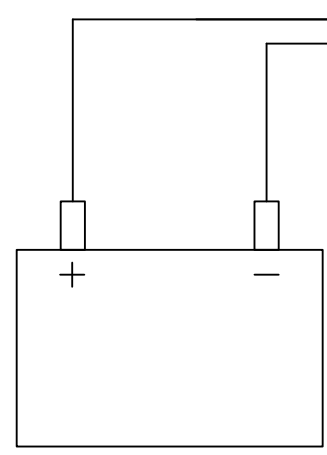
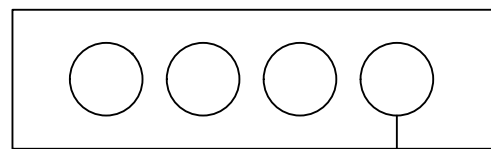
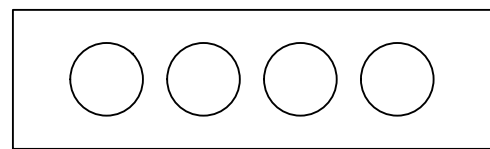

150AMP BREAKER
15AMP FUSE

WHITE 10 AWG 12V- ————— TO ENGINE CONTROLS
BLACK 1/0 AWG 12V+ ————— TO STARTER
BLACK 14 AWG 12V+ ————— TO ENGINE CONTROLS
BLACK 1/0 AWG 12V- ————— GROUNDED TO MOTOR HOUSING

BLACK 2/0 AWG 12V+
BLACK 2/0 AWG 12V-



TITLE: FUEL LUBE SCHEMATIC COLEMAN		DATE 10/29/24
SIZE B	DRAWING NO. 2187-1045	REV 0
SCALE: NTS	DRAWN BY: JS	SHEET 13 OF 13

NOTES:

① END UPFITTER NEEDS TO RUN WIRES TO THE CAB AND INSTALL A SWITCH.

② IGN WAS SPLICED OFF PIN G TO PROVIDED IGN TO OUR SOLENOID TO POWER ON CURRY SYSTEM. SPLICE LOCATION IS LOCATED AT THE CONTROL PANEL.

③ RUN 2/0 WIRE TO FRAME

SHEET REFERENCE:



- SHEET 1 - NOTES SHEET
- SHEET 2 - ELECTRICAL PANEL WIRING FOR LIGHTS
- SHEET 3 - EXTERIOR WIRING FOR LIGHTS
- SHEET 4 - ELECTRICAL PANEL WIRING FOR FILL/EMPTY LIGHTS AND FLOW LINE MONITOR
- SHEET 5 - LEVEL SENSOR WIRING
- SHEET 6 - ELECTRICAL PANEL WIRING FOR PRODUCTS / GREASE / HYD COOLER
- SHEET 7 - EXTERIOR WIRING FOR PRODUCTS / GREASE / HYD COOLER
- SHEET 8 - ELECTRICAL PANEL WIRING FOR COMPRESSOR / W/O ANTI / DEF / COMPT LIGHTS AND IGN SIGNAL FROM CONTROL PANEL
- SHEET 9 - ELECTRICAL PANEL WIRING FOR COMPT HEATING WIRING
- SHEET 10 - IGN WIRING FOR ELECTRICAL PANEL
- SHEET 11 - ELECTRICAL PANEL WIRING FOR CAN BUS/DATA PANEL PRODUCT
- SHEET 12 - HOSE REEL WIRING
- SHEET 13 - HATZ MOTOR WIRING

REVISION TABLE

ZONE	REV	DESCRIPTION	DATE	APPROVED
SHEET 4	1	CHANGE THE FILL SYMBOL TO A BIG LIGHT, THE EMPTY SYMBOL TO THE SMALL LIGHT, AND UPDATE THE PRODUCT IDENTIFIER TO ACCURATELY REFLECT HOW ITS LABELED IN PRODUCTION	12/06/2024	JS



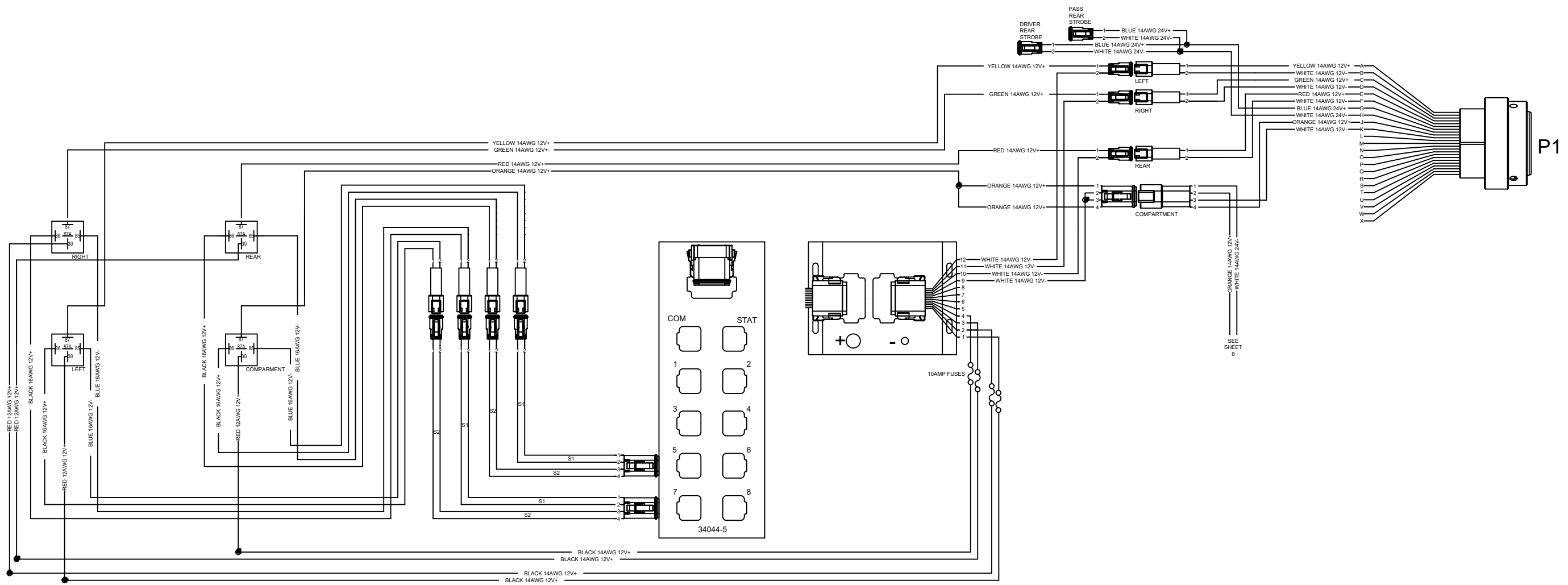

TITLE: STOCK FUEL LUBE SCHEMATIC		DATE 10/29/24
SIZE B	DRAWING NO. 2187-1052	REV 1
SCALE: NTS	DRAWN BY: JS	SHEET 1 OF 13



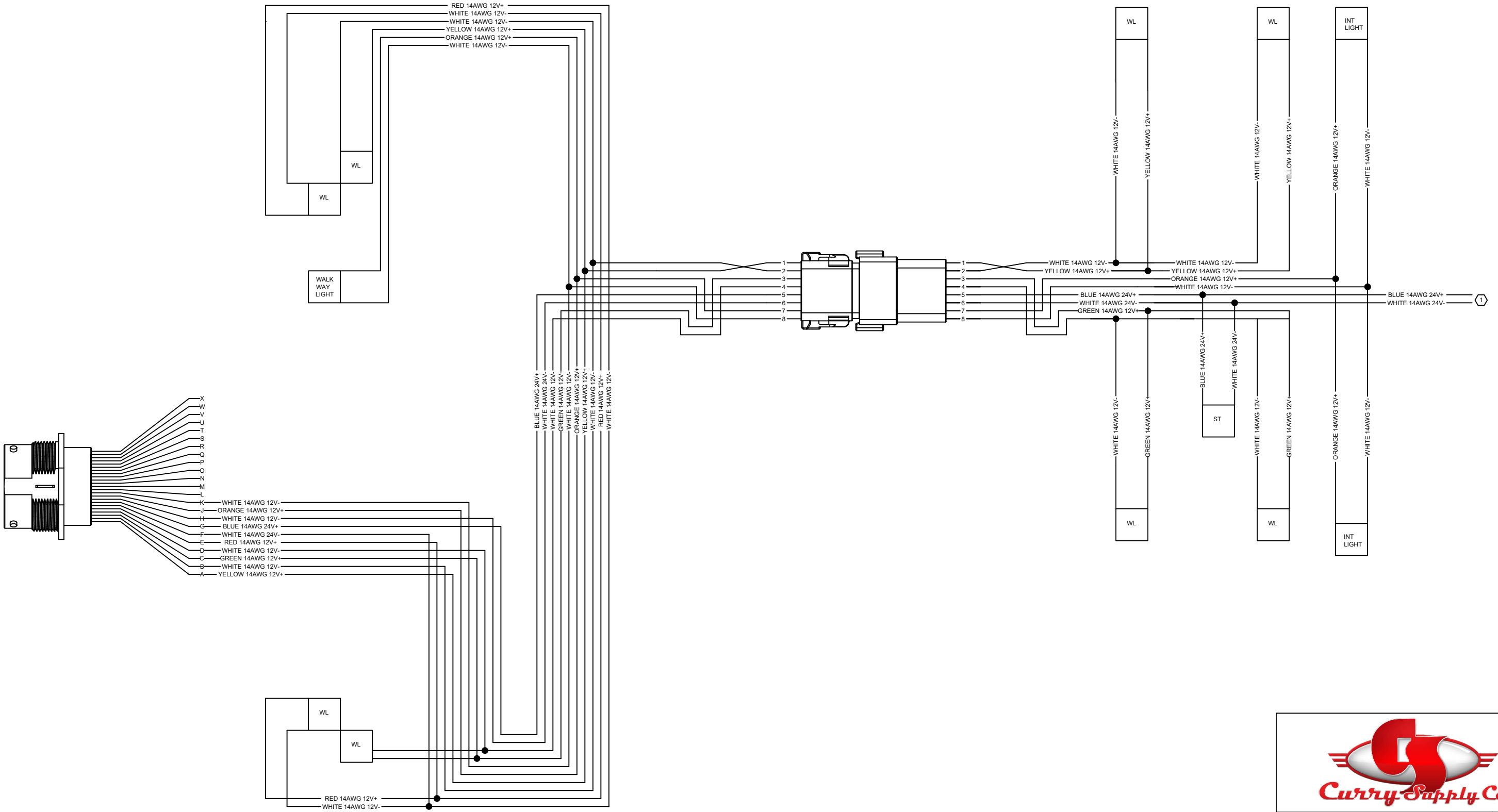

TITLE: STOCK FUEL LUBE SCHEMATIC		DATE 10/29/24
SIZE B	DRAWING NO. 2187-1052	REV 1
SCALE: NTS	DRAWN BY: JS	SHEET 2 OF 13

J1



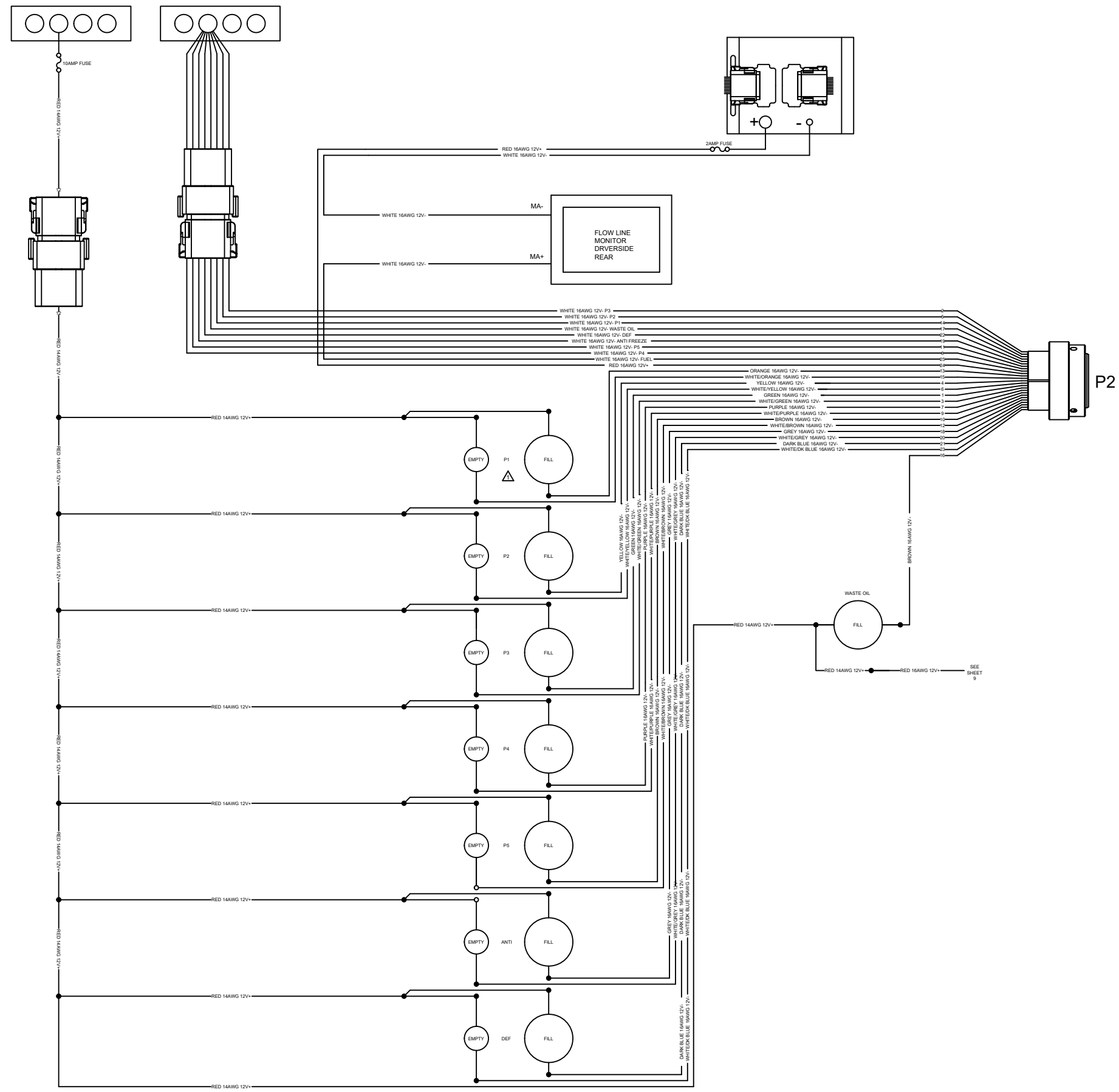

TITLE: STOCK FUEL LUBE SCHEMATIC		DATE 10/29/24
SIZE B	DRAWING NO. 2187-1052	REV 1
SCALE: NTS	DRAWN BY: JS	SHEET 3 OF 13

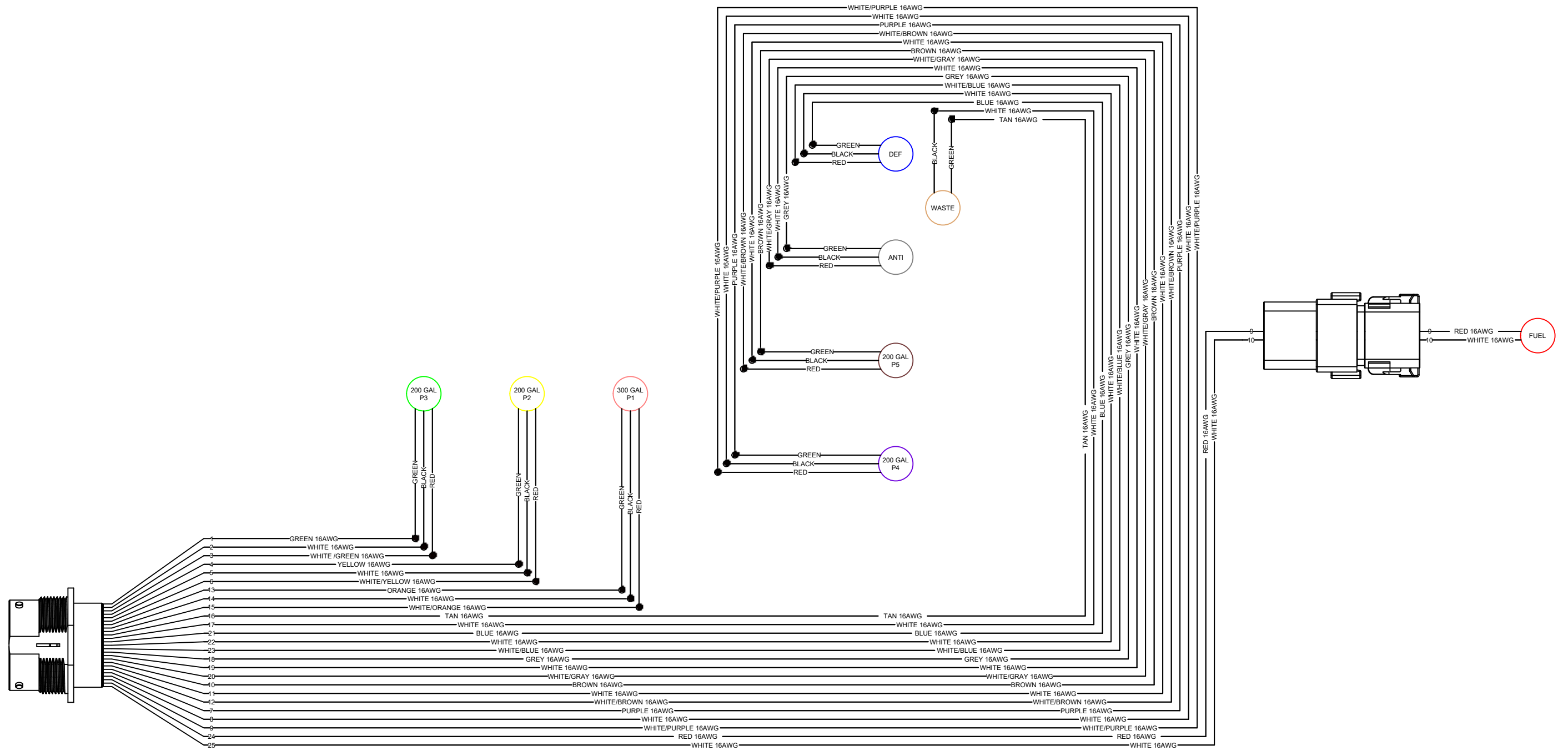

TITLE: STOCK FUEL LUBE SCHEMATIC		DATE 10/29/24
SIZE B	DRAWING NO. 2187-1052	REV 1
SCALE: NTS	DRAWN BY: JS	SHEET 4 OF 13

J2



TITLE: STOCK FUEL LUBE SCHEMATIC		DATE 10/29/24
SIZE B	DRAWING NO. 2187-1052	REV 1
SCALE: NTS	DRAWN BY: JS	SHEET 5 OF 13

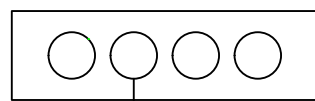

10AMP FUSE

RED 14AWG 12V+

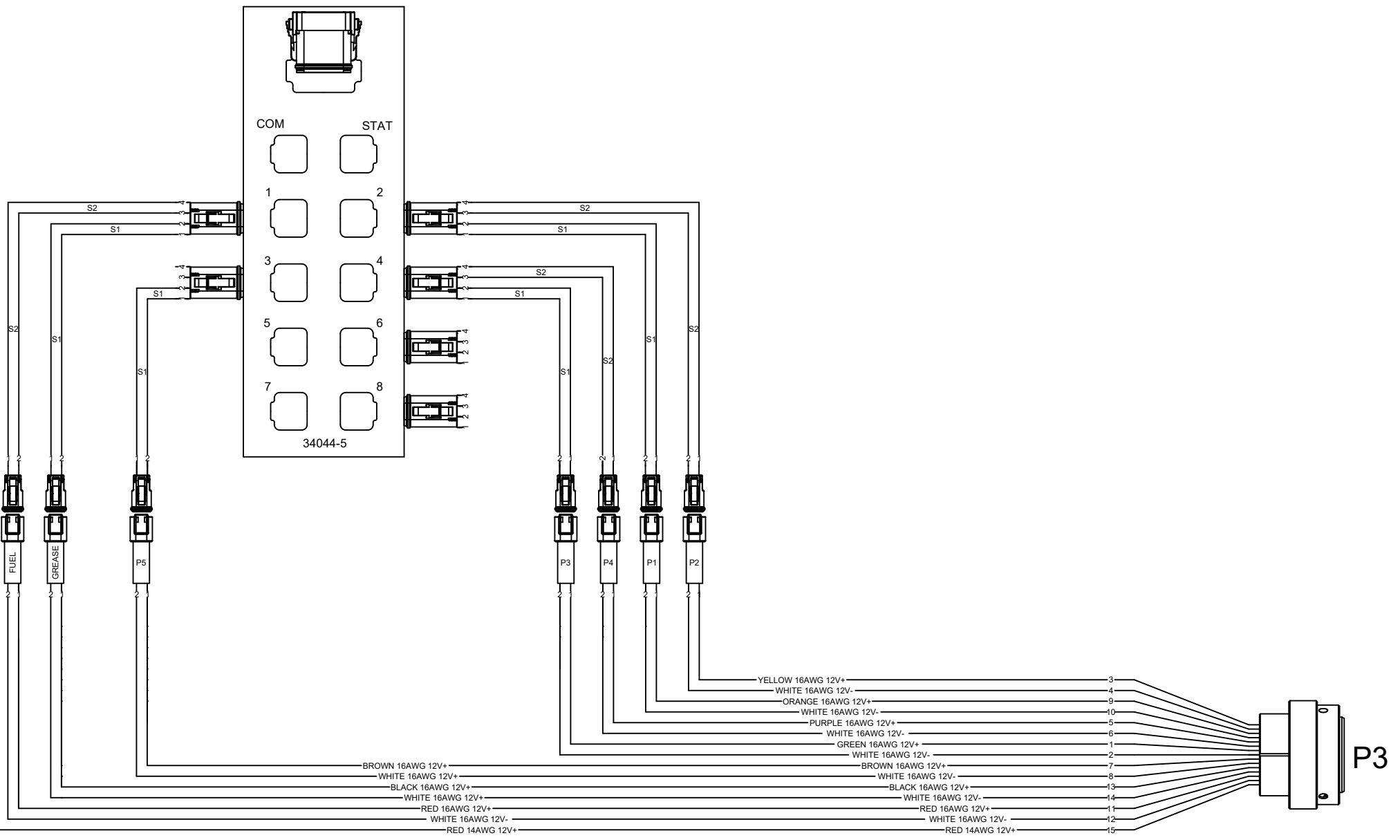

RED 14AWG 12V+

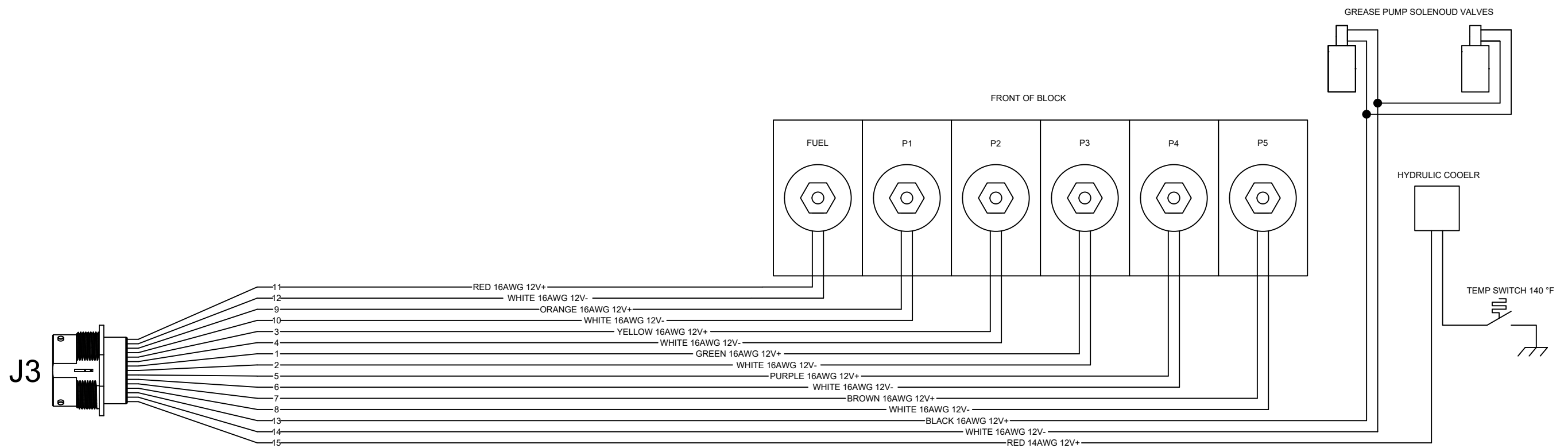

TITLE: STOCK FUEL LUBE SCHEMATIC		DATE 10/29/24
SIZE B	DRAWING NO. 2187-1052	REV 1
SCALE: NTS	DRAWN BY: JS	SHEET 6 OF 13

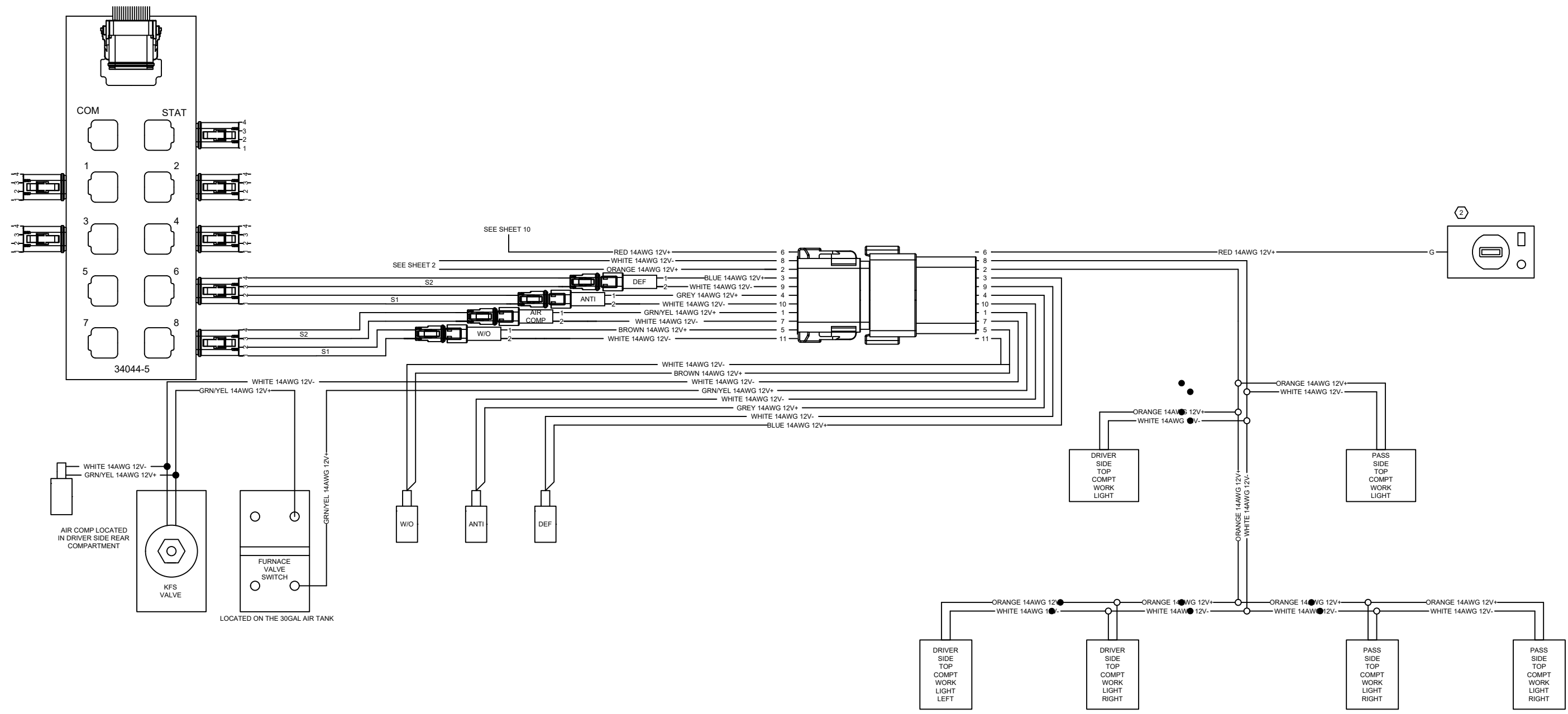

TITLE: STOCK FUEL LUBE SCHEMATIC		DATE 10/29/24
SIZE B	DRAWING NO. 2187-1052	REV 1
SCALE: NTS	DRAWN BY: JS	SHEET 7 OF 13



TITLE: STOCK FUEL LUBE SCHEMATIC		DATE 10/29/24
SIZE B	DRAWING NO. 2187-1052	REV 1
SCALE: NTS	DRAWN BY: JS	SHEET 8 OF 13

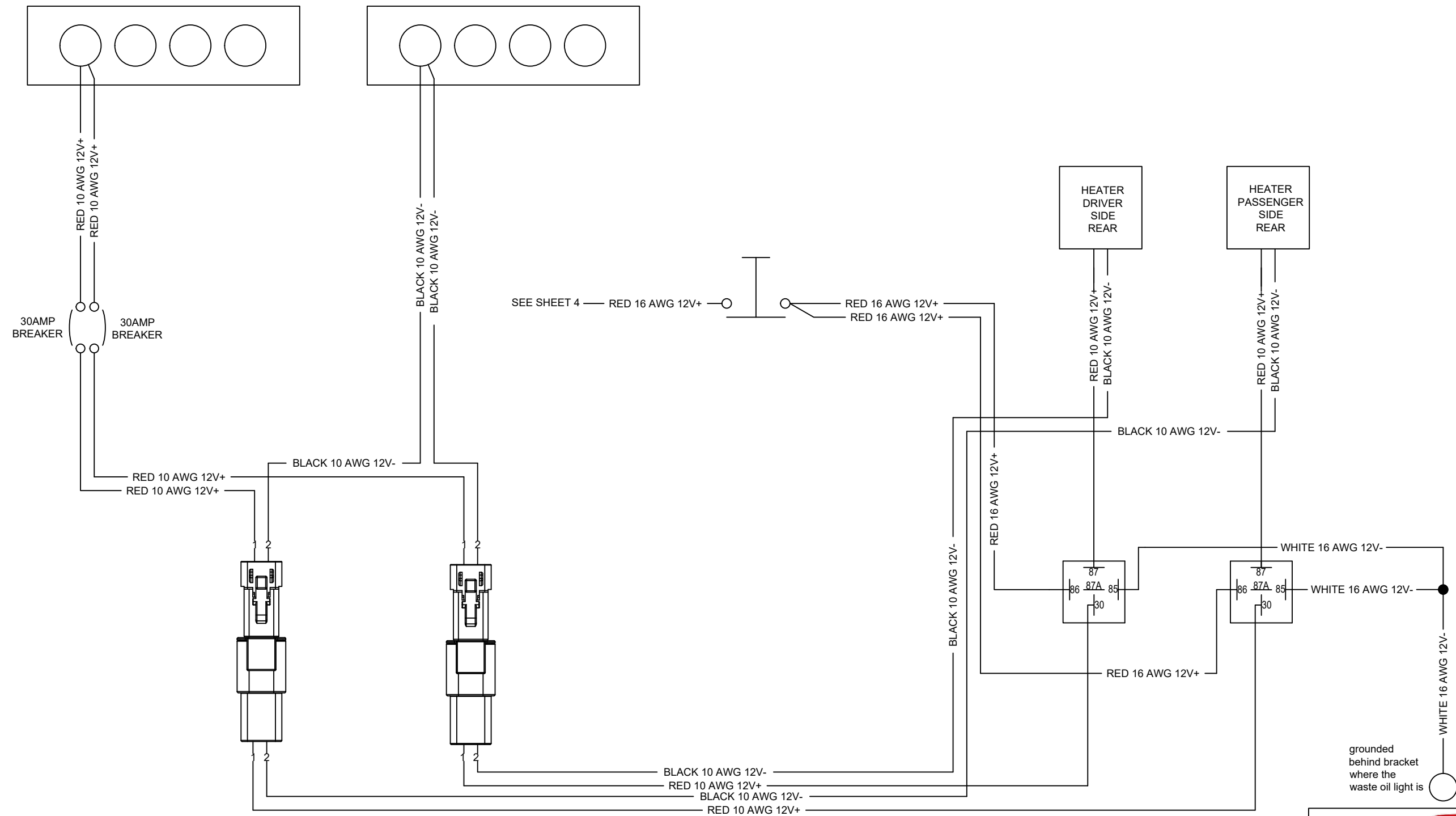

TITLE: STOCK FUEL LUBE SCHEMATIC		DATE 10/29/24
SIZE B	DRAWING NO. 2187-1052	REV 1
SCALE: NTS	DRAWN BY: JS	SHEET 9 OF 13

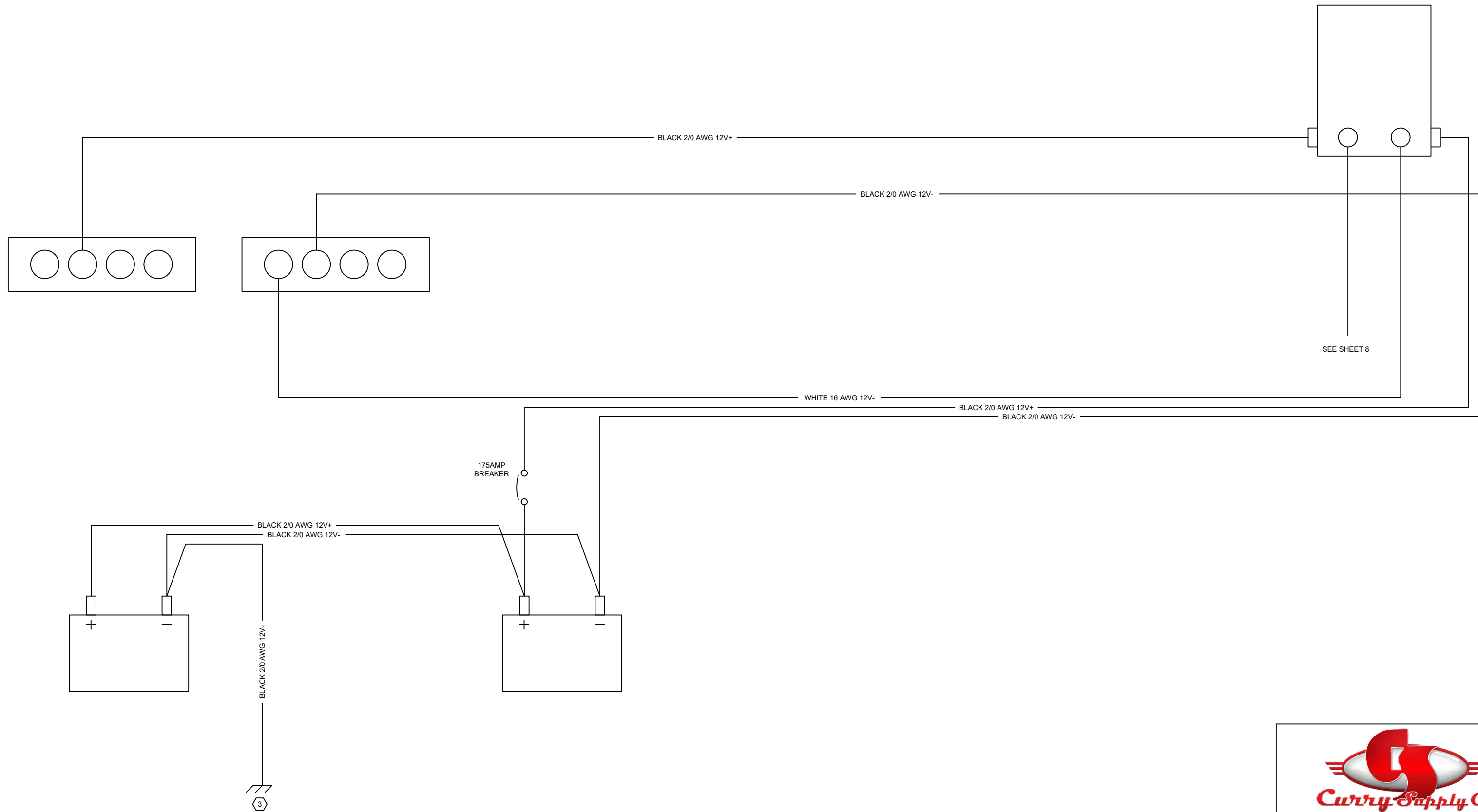

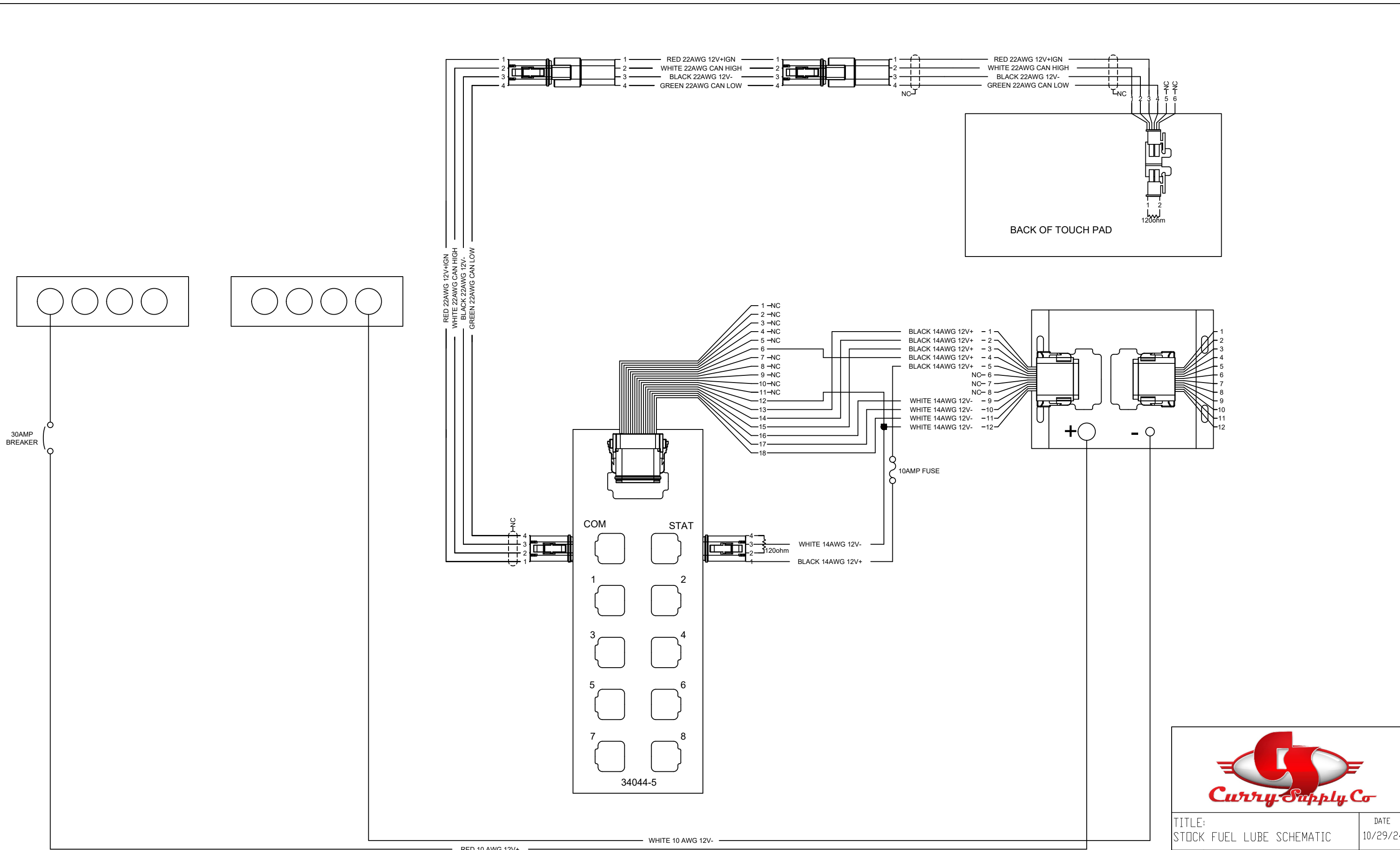
TITLE: STOCK FUEL LUBE SCHEMATIC		DATE 10/29/24
SIZE B	DRAWING NO. 2187-1052	REV 1
SCALE: NTS	DRAWN BY: JS	SHEET 10 OF 13

TITLE: STOCK FUEL LUBE SCHEMATIC		DATE 10/29/24
SIZE B	DRAWING NO. 2187-1052	REV 1
SCALE: NTS	DRAWN BY: JS	SHEET 11 OF 13

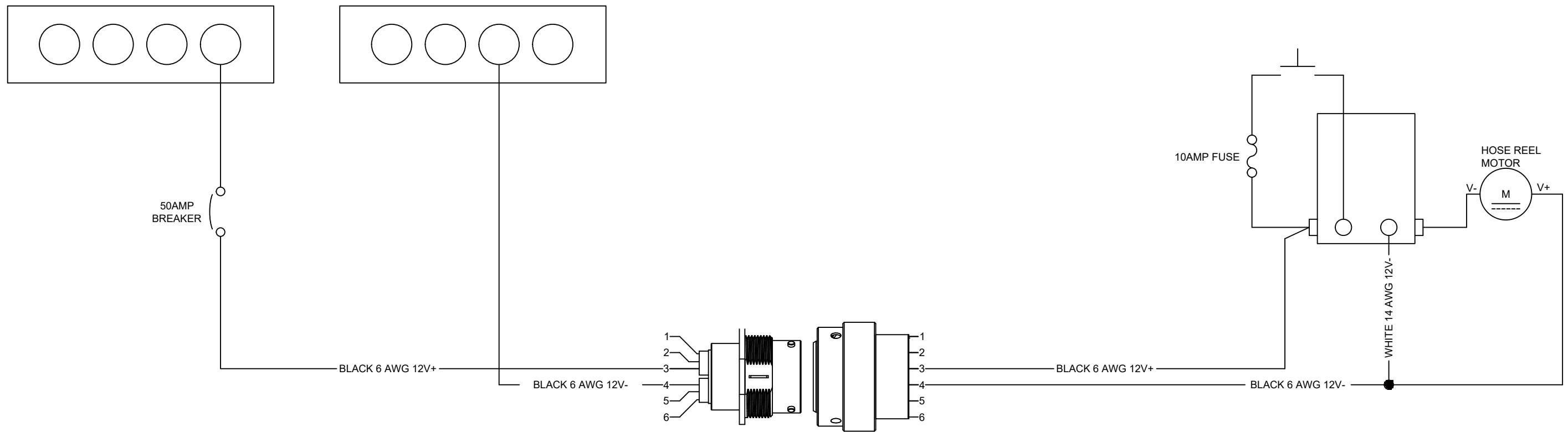

TITLE: STOCK FUEL LUBE SCHEMATIC		DATE 10/29/24
SIZE B	DRAWING NO. 2187-1052	REV 1
SCALE: NTS	DRAWN BY: JS	SHEET 12 OF 13

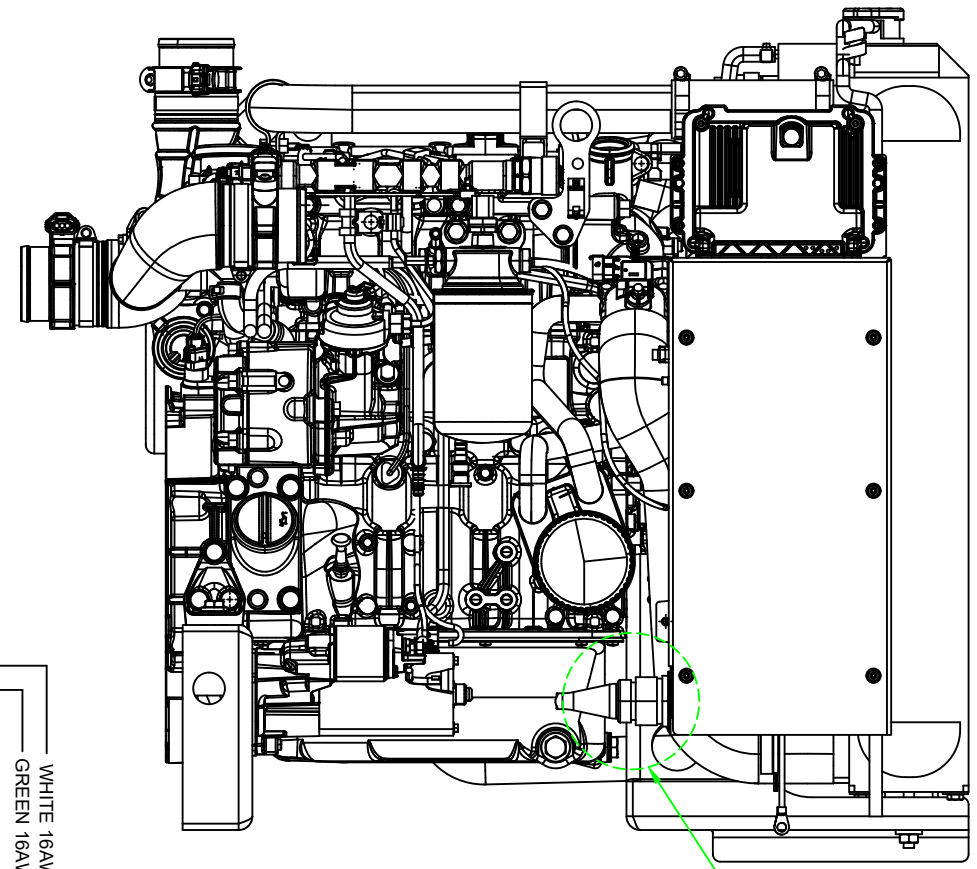
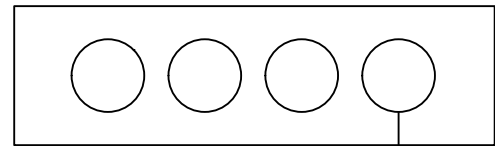
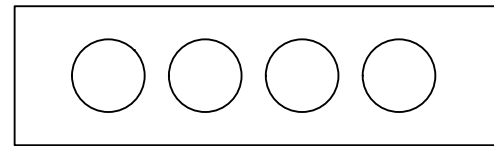

SOFT
START
SOL

WHITE 16AWG 12V-
GREEN 16AWG 12V+

YEL/RD
BLACK

YEL/RD
BLACK

WHITE 10 AWG 12V-

BLACK 1/0 AWG 12V+

BLACK 10 AWG 12V+

BLACK 1/0 AWG 12V-

TO ENGINE CONTROLS

TO STARTER

TO ENGINE CONTROLS

GROUNDED TO MOTOR HOUSING

150AMP
BREAKER

15AMP
FUSE

BLACK 2/0 AWG 12V+

BLACK 2/0 AWG 12V-

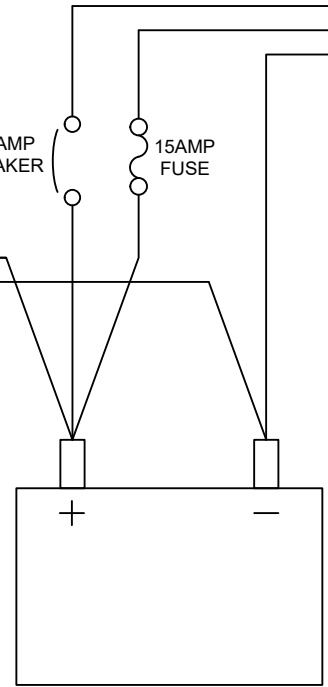
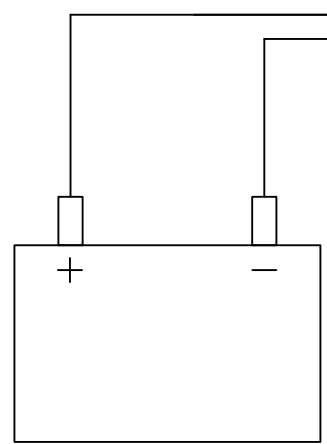

TITLE: STOCK FUEL LUBE SCHEMATIC		DATE 10/29/24
SIZE B	DRAWING NO. 2187-1052	REV 1
SCALE: NTS	DRAWN BY: JS	SHEET 13 OF 13