



Operator Manual

Fuel Lube Truck Off Road Articulated



Curry Supply Co., 1477 Degol Industrial Drive, Hollidaysburg, PA 16648

YOUR JOBS. OUR TRUCKS.



TABLE OF CONTENTS

Sections

Introduction & Safety Messages.....	3
System Descriptions.....	5
Normal Operations.....	14
Maintenance and Lubrication.....	31
Schematics.....	35
Troubleshooting.....	36
Warranty & Proprietary Information.....	39

SECTION 1

Introduction & Safety Messages

CONTACT US

Curry Supply Company

1477 DeGol Industrial Drive, Hollidaysburg, PA 16648

service@currysupply.com CurrySupply.com

Parts 800.567.5127

Warranty Service 800.345.2829

MANUAL USAGE

This Operators Manual contains information to safely operate more than (1) configuration of "Curry Supply Off-Road Articulated Lube Trucks". The parts shown may not reflect the exact configuration on your truck. "Custom" style trucks may have parts not listed. If your system is not covered in this manual, please contact Curry Supply Company support at 800-345-2829 or service@currysupply.com.

All personnel working on or operating the machine must become familiar with the following safety messages.

Due to the nature of these processes, ensure that all safety information, warnings, and instructions are read and understood before any operation or maintenance procedures are performed.

This manual does not supersede any local, state, or federal laws.

SAFETY MESSAGES

The following definitions are found throughout this manual and apply as follows:

WARNING

OPERATING PROCEDURES AND TECHNIQUES COULD RESULT IN PERSONAL INJURY OR LOSS OF LIFE IF NOT FOLLOWED CORRECTLY.

CAUTION

OPERATING PROCEDURES AND TECHNIQUES WHICH COULD RESULT IN DAMAGE TO EQUIPMENT IF NOT FOLLOWED CORRECTLY.

NOTE

OPERATING PROCEDURES AND TECHNIQUES THAT ARE CONSIDERED ESSENTIAL TO EMPHASIZE.

WARNING

IMPROPER USE OF EQUIPMENT
COULD CAUSE SERIOUS INJURY OR
DEATH. PLEASE READ AND
UNDERSTAND ALL INSTRUCTIONS.



WARNING

WHEN OPERATING OR WORKING
ON THE UNIT, KEEP HANDS AND
BODY PARTS CLEAR OF PINCH
POINTS.



WARNING

CONTACT WITH LIVE
ELECTRICAL CIRCUITS COULD
DAMAGE EQUIPMENT OR CAUSE
INJURY.



WARNING

MOVING PARTS CAN CRUSH
AND CUT. KEEP HANDS, FEET,
HAIR, AND LOOSE CLOTHING
AWAY FROM MOVING PARTS.



CAUTION

ADVERSE WEATHER CONDITIONS
CAN CAUSE EQUIPMENT DAMAGE.
WHENEVER POSSIBLE, PERFORM
MAINTENANCE INDOORS.



WARNING

ALWAYS WEAR THE PROPER PPE
WHILE OPERATING THE UNIT.



WARNING

DO NOT OPERATE THE UNIT WHILE
INTOXICATED OR EXTREMELY
EXHAUSTED.



WARNING

DO NOT WALK ON TOP OF THE
VEHICLE. FALLING FROM
VEHICLE CAN RESULT IN
SERIOUS INJURY.



CAUTION

DRAIN ALL WATER DAILY DURING
FREEZING TEMPERATURES.
FREEZING WATER CAN RESULT IN
DAMAGE TO EQUIPMENT.



WARNING

THE VEHICLE IS EQUIPPED WITH A
BACK-UP ALARM. ALARM MUST
SOUND WHEN OPERATING THIS
VEHICLE IN REVERSE.



WARNING

ALWAYS WEAR YOUR SAFETY
BELT WHILE DRIVING THE VEHICLE.
IF VEHICLE TIPS, STAY BUCKLED
AND INSIDE OF CAB AREA.



SECTION 2

System Descriptions

SIDE VIEW OF TRUCK



REAR VIEW OF TRUCK



FRONT VIEW OF TRUCK



The truck shown in the pictures has a Curry Supply Company body on a Volvo chassis. This Operator's Manual provides information on how to safely operate more than one version of the "Curry Supply Company Fuel Lube Off Road Articulated" truck. The truck shown may not exactly match your truck's configuration. "Custom" trucks may have different parts that aren't listed here. If your system isn't covered in this manual, please contact Curry Supply Co. Support at 800-345-2829 or service@currysupply.com.

EQUIPMENT

Trucks are manufactured with various equipment combinations. Find more information about these components by clicking the links in the following table. If unsuccessful finding the information needed, call Curry Supply Company at 1-800-345-2829.

19-Feb-25

Equipment	Manufacturer	Web Link
Truck	Caterpillar	745C Articulated Truck
	Volvo	A25D & A30D Articulated Truck
Remote Engine	Motorenfabrik Hatz GmbH & Co. KG	4H50TIC
Compressor	Atlas Copco Airpower n.v.	LE7-10UVB 8115460019
Pump Sliding Vane	Blackmer	TXD2A_TXD2.5A
Dry Disconnect	Banjo Corp	DM100SS_DM150SS_DM200SS
Digital Meter	Flowline Inc.	LI23
Liquid Level Transmitter		LU80
Product Dispensing Meter	Graco Inc.	EM8_EM20_IM20
Product Dispensing Valve		SDV15_XDV20
Grease Dispense Valve		Proshot 309032
Diaphragm Pump		Husky 1590
		Husky 1050A
		Husky 515
Piston Pump		Fire-Ball 425
Lube Equipment – Couplers, Adapters, Nozzles & Z-Swivels		Lube Equipment
Meter Register Fuel	Veeder-Root	7886 & 7887 Register
Strainer Fuel Meter	Liquid Controls Group	Model A2342
Air & Vapor Eliminator Fuel Meter		Model M-7-1
Compartment Heater	DAS Companies, Inc.	RoadPro 12-Volt Ceramic
Beacon/Strobe Light	Federal Signal Corporation	Spire 100 LED Beacon
Reels	Hannay Reels, Inc.	N700 Series
		N800 Series
		N7500 Series Power Rewind



800.345.2829

www.CurrySupply.com



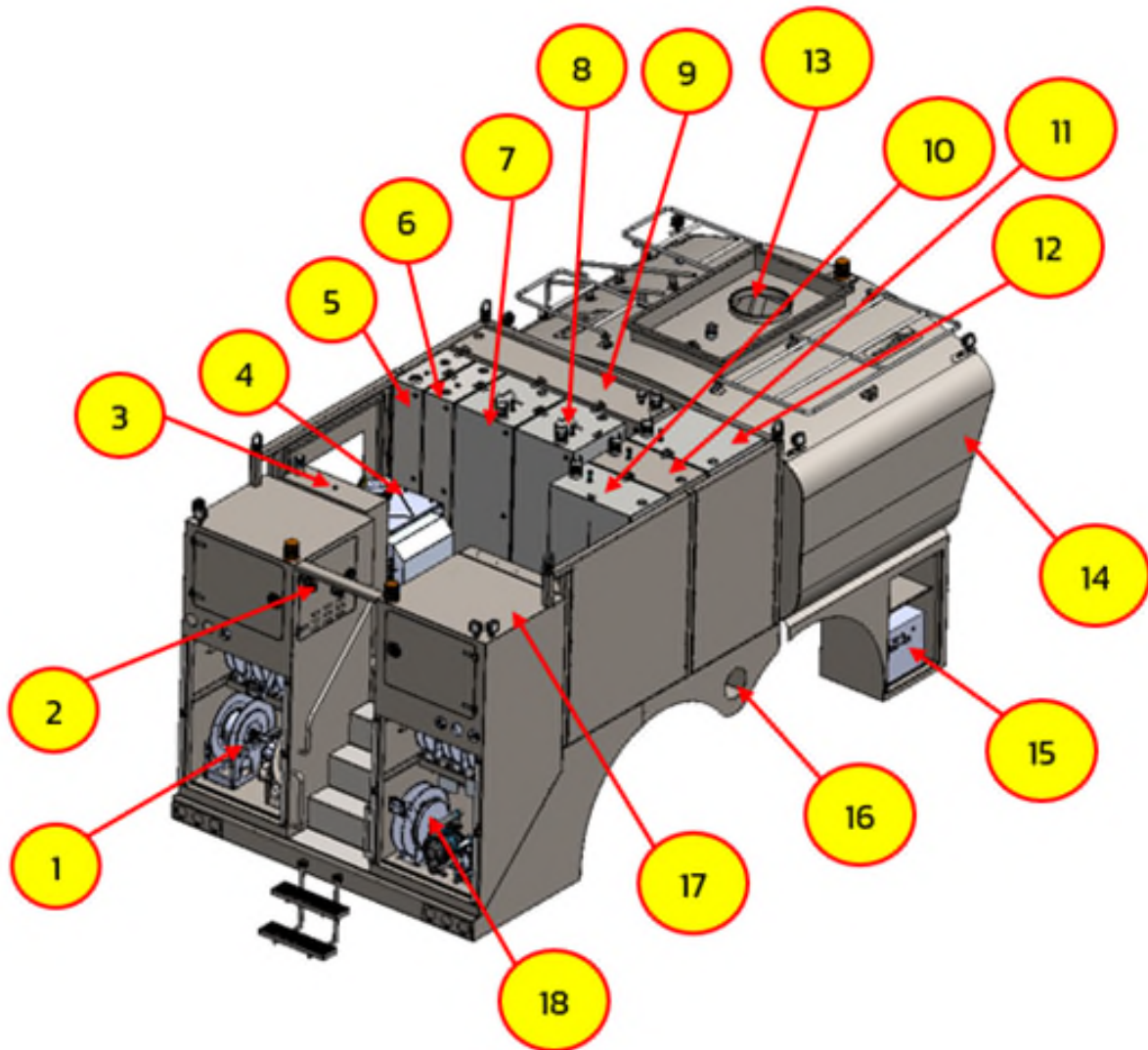

- | | |
|---|--|
| 1. Driver's Side Rear Compartment | 10. Owner's Choice Product Tank #3 (200 Gal) |
| 2. Air Compressor Compartment | 11. Owner's Choice Product Tank #2 (200 Gal) |
| 3. Hydraulic Fluid Reservoir (70 Gal) | 12. Owner's Choice Product Tank #1 (300 Gal) |
| 4. Remote Engine | 13. Fuel Tank 16" Manway Lid |
| 5. DEF Product Tank (100 Gal) | 14. 4,000 Gallon Fuel Tank |
| 6. Antifreeze Product Tank (100 Gal) | 15. Waste/Used Filter Box |
| 7. Owner's Choice Product Tank #5 (200 Gal) | 16. Grease Fill Port |
| 8. Owner's Choice Product Tank #4 (200 Gal) | 17. Electronics, Air Regulators & Batteries |
| 9. Waste/Used Oil Tank (400 Gal) | 18. Passenger Side Rear Compartment |

DRIVER SIDE REAR COMPARTMENT

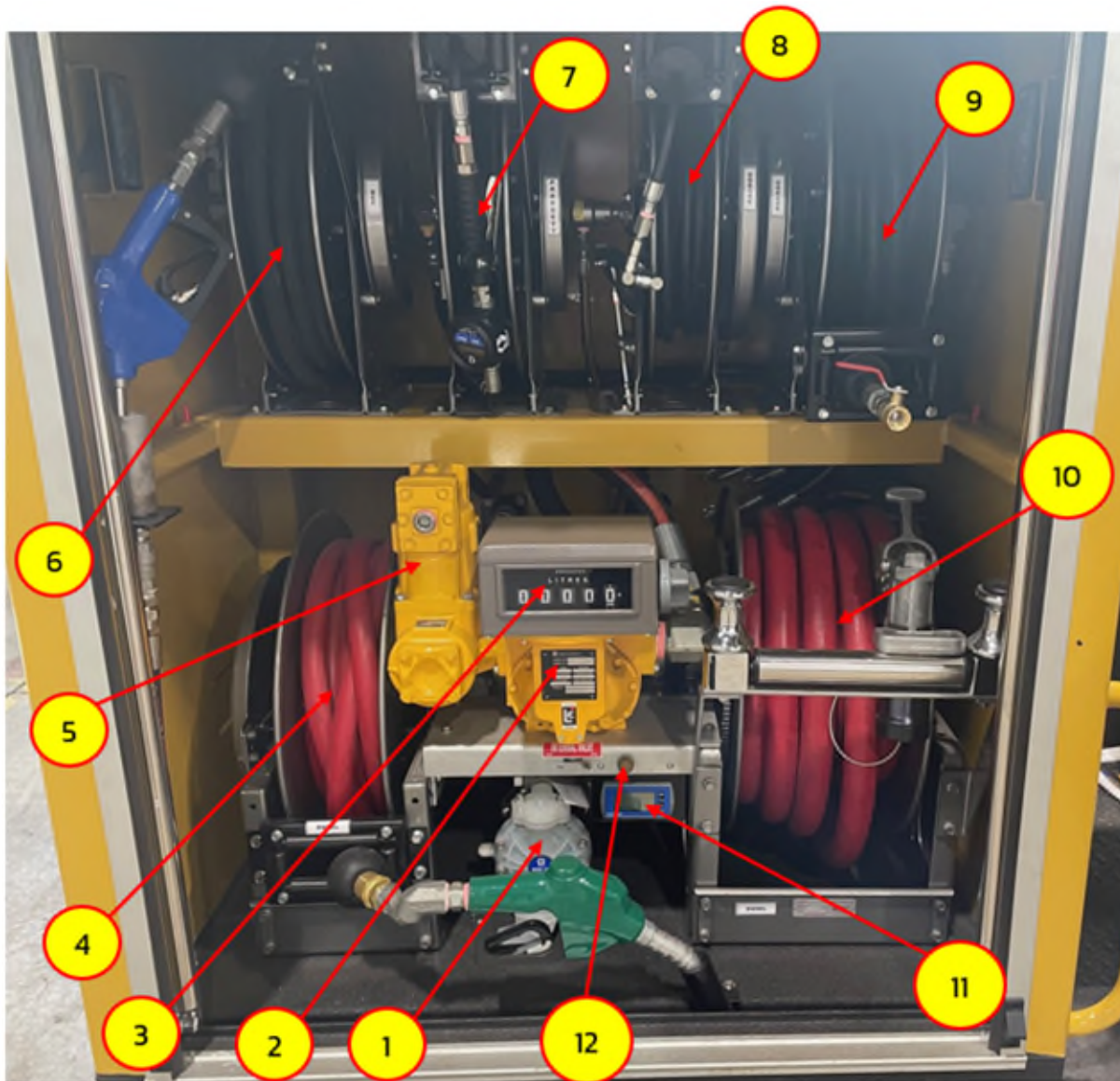

1. Diaphragm Pump for DEF Dispensing
2. Meter Drive
3. Fuel Dispensing Meter
4. 1" Low Flow Fuel Hose on Spring Return Reel
5. Air & Vapor Eliminator
6. DEF Dispensing Hose & Reel
7. Owner's Choice Prod #1 Dispensing Hose on Spring Return Reel
8. Grease Dispensing Hose w/ Proshot Tip on Spring Return Reel
9. Grease Dispensing Hose w/ Ball Valve Tip on Spring Return Reel
10. 1-1/2" High Flow Fuel Hose on Electric Return Reel
11. Fuel Tank Level Meter
12. Power Switch for Electric Return Reel

NOTE
A COMPARTMENT HEATER IS MOUNTED TO THE TOP OF THE COMPARTMENT NOT VISIBLE IN THIS PICTURE.

PASSENGER SIDE REAR COMPARTMENT

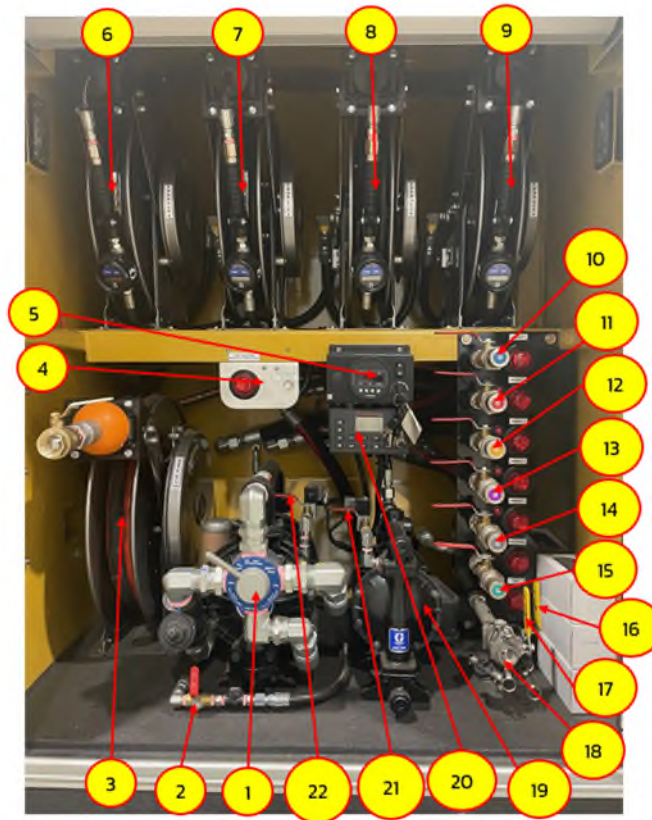

- | | |
|--|--|
| <ol style="list-style-type: none"> 1. 3-way valve for waste oil 2. Ball valve for waste oil filter box 3. 1-1/4" hose on spring return hose for waste oil 4. Waste Tank Full Indicator Light & Compartment Heaters switch 5. Remote Engine Ignition Switch 6. Owner's Choice Product 2 Dispense Hose on Spring Return Reel 7. Owner's Choice Product 3 Dispense Hose on Spring Return Reel 8. Owner's Choice Product 4 Dispense Hose on Spring Return Reel 9. Owner's Choice Product 5 Dispense Hose on Spring Return Reel 10. Owner's Choice Product 1 Tank Fill Port | <ol style="list-style-type: none"> 11. Owner's Choice Product 2 Tank Fill Port 12. Owner's Choice Product 3 Tank Fill Port 13. Owner's Choice Product 4 Tank Fill Port 14. Owner's Choice Product 5 Tank Fill Port 15. Antifreeze Tank Fill Port 16. Ball Valve 17. Ball Valve 18. DEF Tank Fill Port with dry disconnect valve 19. Diaphragm Pump 20. Control Panel 21. Ball Valve 22. Ball Valve |
|--|--|

NOTE

A COMPARTMENT HEATER IS MOUNTED TO THE TOP OF THE COMPARTMENT NOT VISIBLE IN THIS PICTURE.

DRIVER SIDE LOWER COMPARTMENT

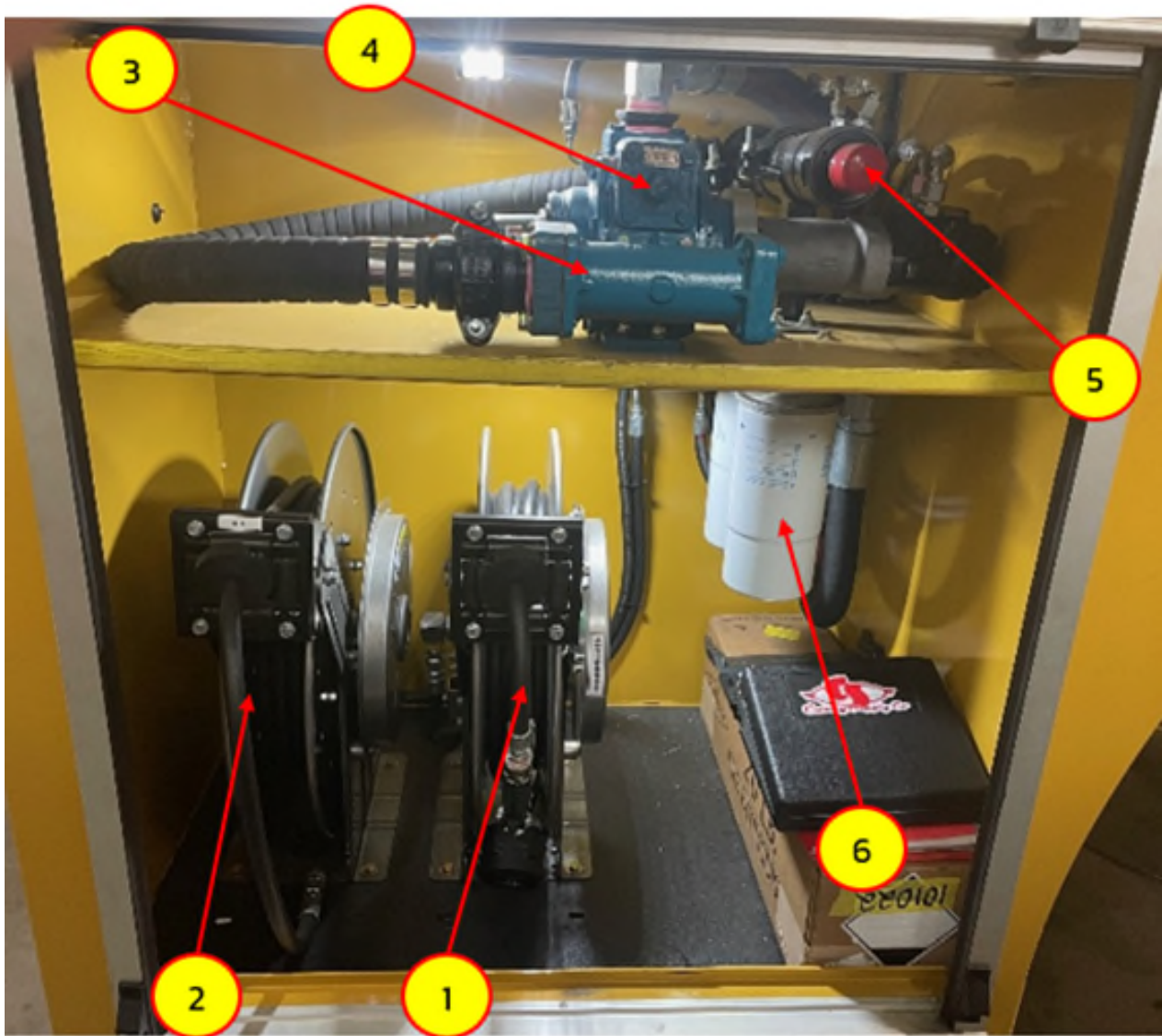

- 1. Antifreeze Dispense Hose on Spring Return Reel
- 2. Air Dispense Hose on Spring Return Reel
- 3. Fuel Strainer

- 4. Fuel Pump
- 5. Fuel Fill Tank Port
- 6. Fuel Filters

NOTE

THIS COMPARTMENT IS NOT HEATED.

REMOTE ENGINE 4H50TIC INTAKE SIDE

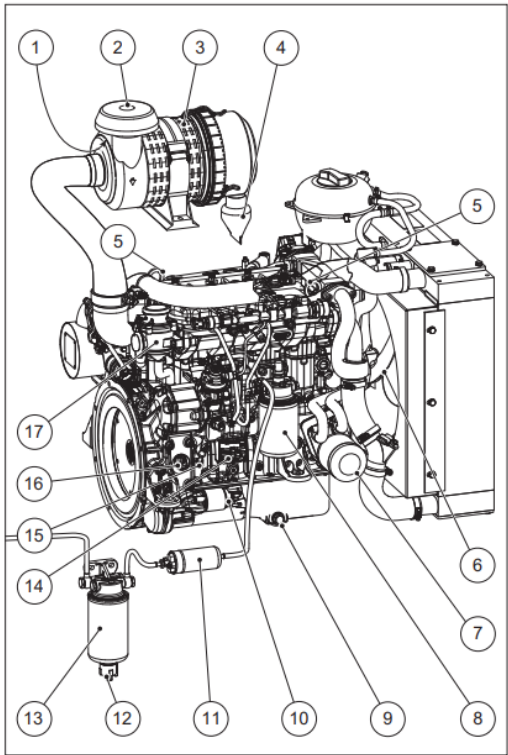

1. Intake opening for combustion air
2. Rain cap
3. Air filter (optional)
4. Dust discharge valve
5. Lifting eyes
6. Fan
7. Oil Filter
8. Fuel Fine Filter
9. Side oil drain screw
10. Starter (low mounting position)
11. Electric fuel pump
12. Drain plug on fuel prefilter
13. Fuel prefilter
14. Engine type plate
15. Dipstick
16. Oil filter plug, bottom
17. Crankcase ventilation

REMOTE ENGINE 4H50TIC EXHAUST SIDE

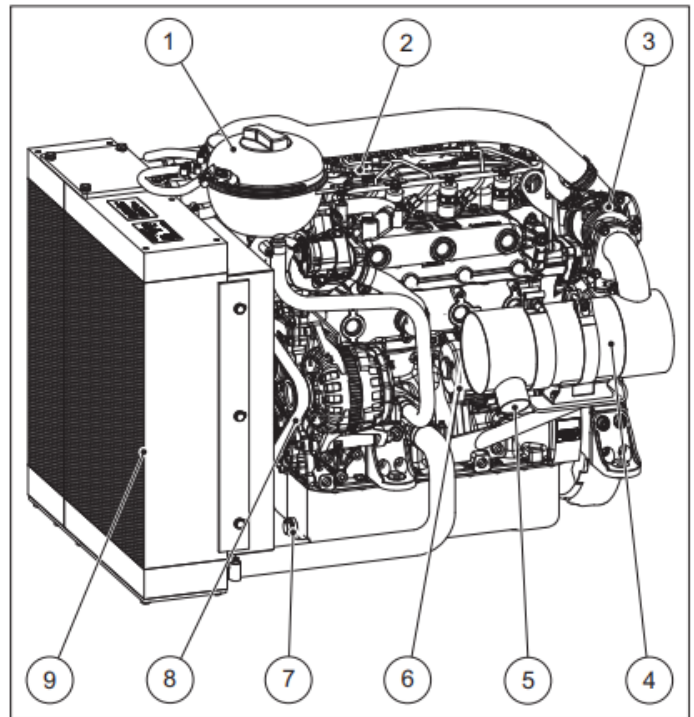

1. Expansion tank for coolant
2. Oil filter plug, top
3. Turbocharger
4. Oxidation catalytic converter
5. Exhaust outlet
6. Starter (high mounting position)
7. Oil drain screw, front
8. Poly v belt
9. Cooler

19-Feb-25

PASSENGER SIDE FRONT LOWER



Used oil filters may be placed in this box to drain. The waste oil collected in the box may be pumped to the waste oil tank using the controls at the rear of the truck.

NOTE

THIS COMPARTMENT IS NOT HEATED.

AIR DRAIN VALVE



Located in the compartment ascending the rear steps on the left This valve must be closed for the air tank to build pressure. Open this valve daily to drain water from the system.

GRACO METER



Some of the fluid dispensing hoses have a meter that shows the amount of fluid passing through the meter. It can display gallons, quarts, pints and liters.

PASSENGER SIDE LOWER



Fill port for the grease tank.

BALL VALVES

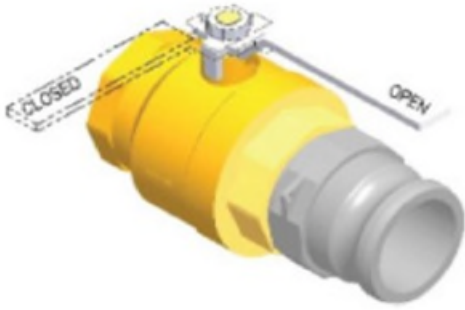

To open the valve, move the handle in line with the tube/hose.

To close the valve, move the handle 90° with the tube/hose.

TOP OF TANK

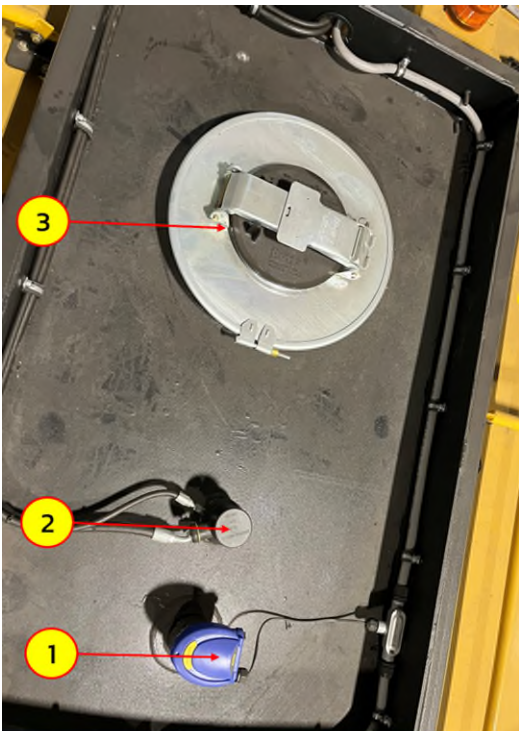

1. Liquid Level Transmitter
2. Level Sensor Nozzle Shut-off and Vent
3. 20" Manway

SECTION 3

Normal Operations

This section provides the vehicle operator with step-by-step operating procedures for the installed systems.

Prior to any operation, please perform a walk around inspection of the vehicle. Check specifically for any leaks or broken hoses.

TANK FILLING OPERATIONS

Diesel Overhead Tank Fill

1. Ensure the tank fill opening is clear of obstruction.

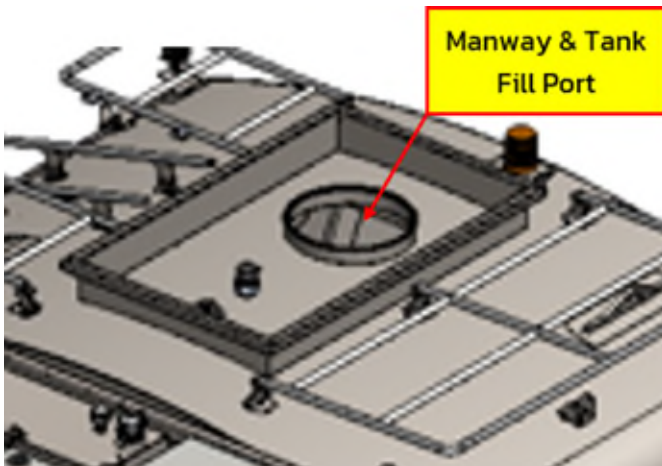

2. Pull the tank under a fill station. Place the vehicle in park/neutral and apply the emergency brake.

3. Unlatch the manway lid and insert the fill hose.



4. In the passenger side rear compartment, turn the ignition switch to "CRANK" to start the remote engine. The display will appear.



5. Begin filling the tank while watching the tank fill gauge on the display.
6. Turn the fuel source off when the tank is full.
7. Turn the ignition switch to "OFF".

Diesel Fast Tank Fill

1. In the lower driver side compartment, take the cap off the receiver port.



2. Attach the wiggins system fuel nozzle to the intake, ensuring that it is locked on before filling with fuel.



3. With your palm on the handle and your fingers on the pullback handle, pull it towards you until the locking dogs lock in the open position. (Figure 1).



Figure 1

4. To check if it is opened, look to see if the dogs are locked and are outside of the inside diameter of the front assembly. (figure 2A (open) figure 2B (closed)).

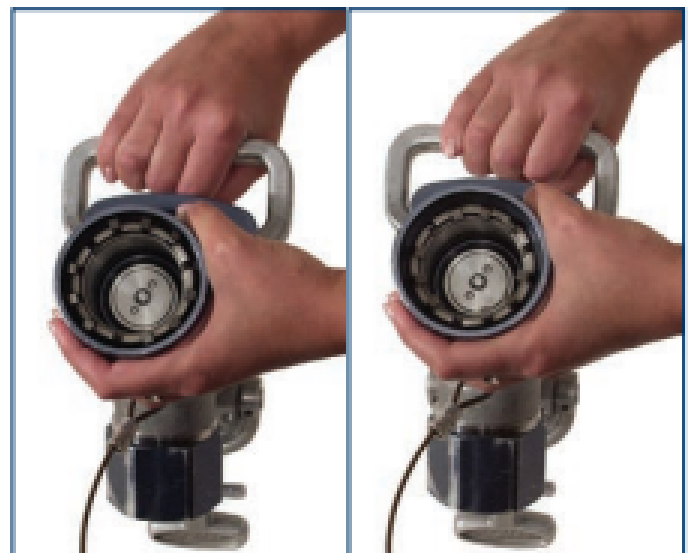

Figure 2A

Figure 2B

19-Feb-25

5. Push the nozzle all the way onto the receiver until the pullback handle snaps forward.

6. Lock the nozzle onto the receiver by lifting up the actuator handle (figure 3).



Figure 3

7. Fill the tank to the desired fuel level and then turn off the fuel source. If filling the tank full, a valve will shut off preventing overflow.

8. Disconnect the wiggins system by reversing steps 3 through 6 and reinstall the cap on the wiggins port.

DISPENSE OPERATIONS

DIESEL FUEL

1. Turn the ignition switch to "CRANK", located in the passenger side rear compartment. The remote engine will start and the display will appear.



2. In the rear driver side compartment, move the internal valve switch to the "ON" position.



- 3. At the front driver side of the tank, move the "EMERGENCY SHUT OFF" to the "ON" position.



NOTE

IF EITHER OF THESE SWITCHES ARE "OFF", DIESEL FUEL OPERATIONS WILL STOP.

- 4. Press the "DIESEL FUEL" button on the control panel. A light embedded in the button will turn on.



- 5. Select the appropriate fuel reel based on the type of nozzle needed for the application (Wiggins or standard).

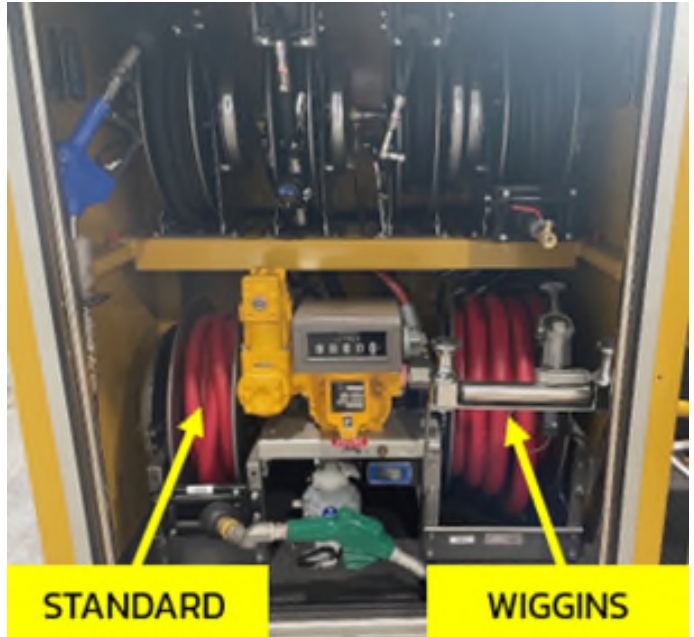

- 6. Begin dispensing fuel while watching the gallons meter and level indicator. Fill to the desired level.



19-Feb-25

- When finished, turn off the diesel fuel button on the control panel, reel in the hose, and move the internal valve switch to the "OFF" position.

NOTE
THE 1-1/2 INCH HIGH-FLOW HOSE REEL IS EQUIPPED WITH AN ELECTRIC MOTOR RETURN. PUSH THE BUTTON TO RETRACT THE HOSE.



- Turn the ignition switch to "OFF".

FILLING PRODUCT TANKS

- Turn the ignition switch to "CRANK", located in the passenger side rear compartment. The remote engine will start and the display will appear.



- Locate the product reels and fill ports in the rear passenger side compartment. Fill ports are different colors and labeled indicating the product in each tank.

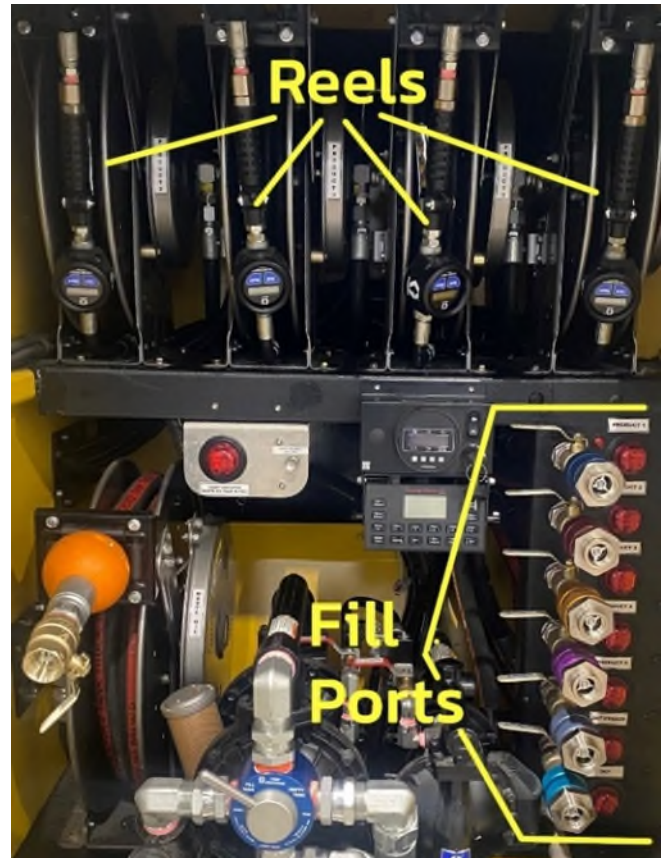

- Push the hose connection onto the corresponding port.

- Open the ball valve of the selected product port and fill the tank. The light will turn on when the tank is full.

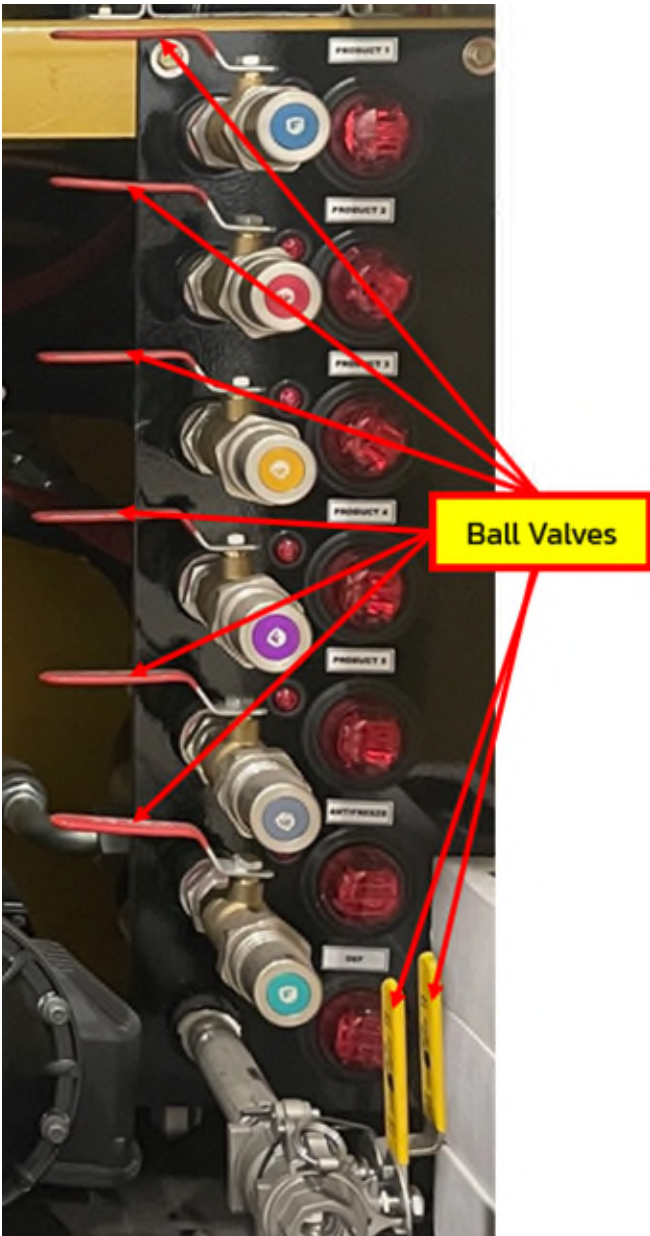

- Once complete, turn off the ball valve & detach the fill hose.
- Turn the ignition switch to "OFF".

DISPENSING METER



Press the "RESET" key to wake up the display and clear the previous quantity before dispensing fluid. The digital display goes blank after one minute of non-use. To wake the display, press the "TOTAL" key or run fluid through the meter. The meter can be adjusted to display different units of measurement:

- Pints (PTS)
- Quarts (QTS)
- Gallons (GAL)
- Liters (L)

To change the unit of measure, press the "TOTAL" & "RESET" keys together. All the segments of the digital display illuminate for 6 seconds. The software revision displays for 2 seconds. The meter goes blank and the volume unit blinks. The meter is now in Setup Mode. Release the "TOTAL" & "RESET" keys. Repeatedly press the "TOTAL" key to change the unit of measure. When the desired unit appears, press the "RESET" key to save the selection.

19-Feb-25

The meter is factory set to display "CAL" when the meter must be calibrated. To calibrate the meter, refer to page 10 of the meter manual. The manual may be obtained by clicking the link in section two of this manual.

Replacement of the meter battery may be found on page 12 in the same manual.

DISPENSING PRODUCTS:

1. Turn the ignition switch to "CRANK", located in the passenger side rear compartment. The remote engine will start and the display will appear.



2. Select the product reel on the control panel (Prod 1, Prod 2, etc.). When the button is pushed, a light embedded in the button will turn on, and the output will change from 0 to 1.



3. Pull the product reel hose to the desired location.



4. The meter display will show the amount of product passing through the meter. Push the reset button to set it to zero (note: the meter may display gallons, quarts, pints and liters. Refer to the "DISPENSING METER" procedure to switch between scales).



19-Feb-25

5. Open the no drip nozzle by turning it counterclockwise until it stops.



6. Push the black thumb lock on the handle and then squeeze the trigger to begin the flow of product.



7. When finished, close the no drip nozzle and retract the hose back onto the reel.
8. Push the button on the control panel to turn off the power to the product reel. The light will turn off.
9. Turn the ignition switch to "OFF".

DISPENSING ANTI-FREEZE

1. Turn the ignition switch to "CRANK", located in the passenger side rear compartment. The remote engine will start and the display will appear.



2. Locate and select the reel labeled "Anti-Freeze", in the driver side lower compartment.



19-Feb-25

3. Locate the diaphragm pump (the one without the 3-way valve) in the rear passenger side compartment and turn the ball valve to the open position.



4. On the control panel, push the "ANTI-FREEZE" button. The light embedded in the button will turn on.



5. Extend the hose from the reel, open the no drip nozzle, and dispense the anti-freeze.



6. When the dispensing is complete, close the nozzle and retract the hose back onto the reel.
7. On the control panel, push the "ANTI-FREEZE" button. The light embedded in the button will turn off.
8. Close the ball valve.
9. Turn the ignition switch to "OFF".

FILLING DEF TANK

1. Turn the ignition switch to "CRANK", located in the passenger side rear compartment. The remote engine will start and the display will appear.



19-Feb-25

2. Locate the DEF dry disconnect ball valves on the lower right side of the rear passenger side compartment.



3. Connect the fill hose using the cam and groove fittings that are provided.
4. Open both ball valves. When the tank is full, the "DEF" light will turn on.
5. Close both ball valves.
6. Turn the ignition switch to "OFF".

DISPENSING DEF FLUID

1. Turn the ignition switch to "CRANK", located in the passenger side rear compartment. The remote engine will start and the display will appear.



2. Turn on the DEF diaphragm pump by pressing the "DEF" button on the control board.



19-Feb-25

3. Locate and extend the hose on the reel labeled "DEF" (upper left side in driver side rear compartment) and begin pumping.



4. When pumping is complete, retract the hose.
5. Turn the DEF pump off on the control panel.
6. Turn the ignition switch to "OFF".

WASTE TANK

SUCKING WASTE OIL AND FILLING WASTE TANK

1. Turn the ignition switch to "CRANK", located in the passenger side rear compartment. The remote engine will start and the display will appear.



2. Locate the 3-way valve in the lower portion of the passenger side rear compartment. Descriptions on the valve are in reference to the waste tank on the truck. "FILL TANK" will pull into the tank. "EMPTY TANK" will expel from the tank. To fill the tank, turn the handle to "FILL TANK".



19-Feb-25

- 3. Locate the ball valve to the right of the diaphragm pump (by the anti-freeze ball valve) and turn it to the open position.



- 6. Open the ball valve on the end of the hose and suck up the waste oil into the tank.

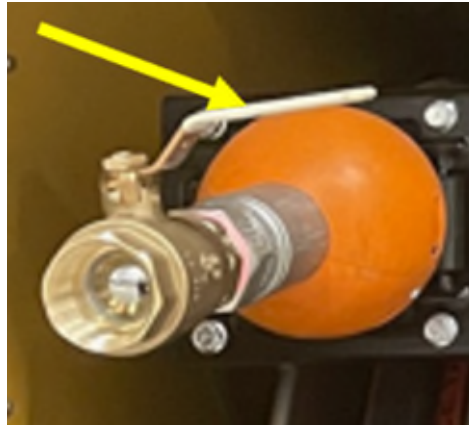

- 4. Locate the "WASTE OIL" button on the control panel and turn it on. A light embedded in the button will turn on.



NOTE
IF SUCKING THE WASTE OIL FROM THE WASTE FILTER BOX, CLOSE BALL VALVE 1 AND OPEN BALL VALVE 2.

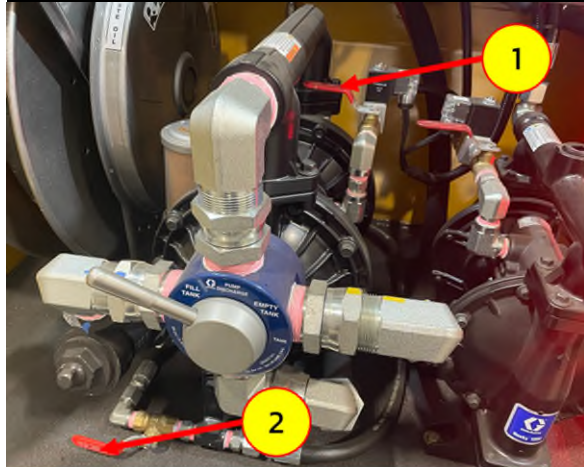

- 5. Extend the hose on the reel labeled "WASTE".



NOTE
THIS LIGHT WILL ILLUMINATE WHEN THE WASTE OIL TANK IS FULL.



19-Feb-25

7. When complete, retract the hose and return the ball valve to the closed position.
8. Press the "WASTE OIL" button on the control panel to turn the waste oil diaphragm pump off.
9. Turn the ignition switch to "OFF".

EMPTYING WASTE TANK

1. Turn the ignition switch to "CRANK", located in the passenger side rear compartment. The remote engine will start and the display will appear.



2. Locate the 3-way valve in the passenger rear compartment. Turn the handle to the "EMPTY TANK" position.



3. Locate the "WASTE OIL" ball valve and turn it to the open position.



4. Press the "WASTE OIL" button on the control panel. The waste oil diaphragm pump will turn on and the light embedded in the button will illuminate.



5. Pull the hose to the designated area and open the ball valve at the end of the hose to begin emptying the contents of the waste oil tank.



- When the tank is empty, close the hose ball valve, turn off the waste oil diaphragm pump by pressing "WASTE OIL" on the control panel, and retract the hose onto the reel.
- Return the diaphragm pump "WASTE OIL" ball valve back to the closed position.



- Open the ball valve behind the port to begin filling.



GREASE TANK

FILLING GREASE TANK

- Locate the grease fill port on the passenger side of the truck, above the rear axle.



- Remove the cap from the fill port.
- Attach the fill-hose using a cam and groove fitting.

- When finished, turn the ball valve back to the closed position.
- Remove the fill-hose.
- Replace the fill port cap.

DISPENSING GREASE

- Turn the ignition switch to "CRANK", located in the passenger side rear compartment. The remote engine will start and the display will appear.



19-Feb-25

2. Press the "GREASE" button on the control panel to turn on the pump. The light embedded in the button will turn on.



3. Locate the grease hoses in the driver's side rear compartment.



4. Choose the reel with the pro-shot nozzle or the ball valve (depending on which is needed).

Proshot



Ball Valve



5. Dispense the grease. Either pull the trigger on the Proshot hose or open the ball valve on the other hose. When complete, release the trigger on the Proshot hose or turn the ball valve to off on the other hose. Retract the hose.

6. Press the "GREASE" button on the control panel to turn off the pump.
7. Turn the ignition switch to "OFF".

AIR TANK

DISPENSE AIR

1. Turn the ignition switch to "CRANK", located in the passenger side rear compartment. The remote engine will start and the display will appear.



2. Press the "AIR COMP" button on the control panel to turn on the air compressor. The light embedded in the button will turn on.



19-Feb-25

3. Locate the reel labeled "AIR" in the lower driver's side compartment.



4. Pull the hose from the reel to the desired location and insert the desired air dispensing fitting into the chuck at the end of the hose.
5. Dispense the air.
6. When finished, retract the hose.
7. Turn off the air compressor by pressing the "AIR COMP" button on the control panel.
8. Turn the ignition switch to "OFF".

COMPARTMENT HEATING

1. Turn the ignition switch to "CRANK", located in the passenger side rear compartment. The remote engine will start and the display will appear.



2. Locate the compartment heater knob in the rear passenger side compartment, next to the "FULL WASTE OIL" warning light. Pull the knob out to turn on the heaters.



NOTE

THE TWO REAR COMPARTMENTS ARE THE ONLY HEATED COMPARTMENTS.

3. When the desired heat is obtained, turn the compartment heaters off.
4. Turn the ignition switch to "OFF".

19-Feb-25

LIGHTS

1. Turn the ignition switch to "RUN". The remote engine does not need to be running, however, if using the lights for an extended time, run the engine to prevent the batteries from depleting.
4. Press the button again to turn the light off.
5. Turn the ignition switch to "OFF".



2. Locate the control panel in the rear passenger side compartment.



3. Turn on the desired lights by pushing the corresponding button on the control panel. A light embedded in the button will indicate power to the light. Lights are labeled (left flood, rear flood, comp't lights, and right flood) on the control panel.

Section 4

Maintenance and Lubrication

Due to numerous jobs and purposes, varying environments and climates, and importance to safety, routine maintenance is highly recommended. Regular maintenance keeps the trucks functioning correctly and at optimum efficiency. The following tasks can help prevent breakdown and keep the truck on the job.

NOTE

FOR THE MOST ACCURATE MAINTENANCE FOR A SPECIFIC CHASSIS SYSTEM, REFER TO THE PRODUCT SPECIFIC USER MANUAL.

DAILY SAFETY MAINTENANCE

Tires – Check for proper inflation and tread depth.

Brake System – Routine inspections on brake pads and calipers for safe operation.

Lights – Check all lights are working and functioning correctly.

Fluids – Check that the engine oil, coolant, Hydraulic fluid, and wiper fluid are all at the right levels.

Hoses – Check for leaks and cracks, and make sure everything is securely fastened.

HYDRAULIC FLUID

FIRST 50 HOURS OF OPERATION

- Replace the fluid and filter.

DAILY

- Check the fluid level daily before use. Fill with fluid that meets specification ISO VG 68. The filter must be rated for 10 micron.



TRUCK BODY COMPARTMENTS

DAILY

- Ensure the doors latch securely.
- Insert the key into each door and turn to lock. Ensure the doors do not open.
- Insert the key into each door and turn to unlock. Ensure the doors open.

MONTHLY

- Lubricate the hinges with white lithium spray lubricant.
- Spray the door locks with lock lubricant.

19-Feb-25

DISPENSING UNIT STRAINER

Clean as needed.

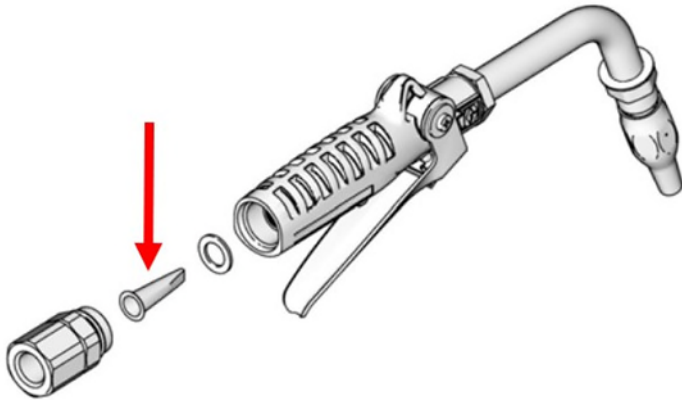

AIR DRAIN VALVE

Drain daily and after each use.



TANK AIR BREATHER

ANNUALLY

Located on top of each product tank. The breather is inside the product cap. Inspect using forced air through the filter. Replace if air does not freely move through the filter.



DIAPHRAGM PUMP

EACH USE

- Check all hoses for wear or damage and replace as necessary.
- Check all threaded connections are tight and leak-free.

EVERY 500 HOURS OR MONTHLY

- remove the hose from the pump air inlet and add two drops of machine oil to the air inlet.

CAUTION

DO NOT OVER-LUBRICATE THE PUMP. OIL IS EXHAUSTED THROUGH THE MUFFLER, WHICH COULD CONTAMINATE THE FLUID SUPPLY OR OTHER EQUIPMENT. EXCESSIVE LUBRICATION CAN ALSO CAUSE THE PUMP TO MALFUNCTION.

AS NEEDED

- Flush the pump often enough to prevent the fluid from drying or freezing in the pump. Use a compatible solvent.
- Always flush the pump and relieve the pressure before storing it for any length of time.

REMOTE ENGINE

WARNING

ONLY PERFORM MAINTENANCE WORK WHEN ENGINE IS SWITCHED OFF.

WARNING

PROTECT THE STARTING KEY FROM UNAUTHORIZED ACCESS.

WARNING

DISCONNECT THE NEGATIVE BATTERY TERMINAL.

WARNING

WHEN THE MAINTENANCE WORK HAS BEEN COMPLETED, ENSURE THAT ALL TOOLS ARE REMOVED FROM THE MACHINE.

Instructions to perform the following tasks can be found in the manufacturer's operating manual. A link to this manual can be found in section two of this manual.

DAILY

- Check the oil level.
- Check the intake area of the combustion air.
- Check the cooler fins from contamination and clean if necessary.
- Check the cooling system.

AFTER THE FIRST 50 OPERATING HOURS

- Change the engine oil & filter.
- Check the screw connections.

EVERY 500 OPERATING HOURS (OR ANNUALLY)

- Diagnosis of engine management to be performed by trained technicians. The engine control module continuously evaluates the engine-relevant data during operation. The service technician can extract and evaluate the data.
- Update engine control unit to be performed by trained technicians. The unit can only be updated using diagnostic software.
- Clean the engine.
- Check the anti-freeze concentration.
- Clean the radiator fins.
- Change the engine oil and filter.
- Check the poly v belt.
- Change the oil separator of the crankcase ventilation.
- Check the screw connections.
- Change the fuel prefilter.
- Change the fuel line filter.
- Drain the charge air cooler.
- Change the air filter cartridges.
- Drain the water separator.

19-Feb-25

EVERY FOUR YEARS

- Change the coolant.

EVERY 3,000 OPERATING HOURS

- Replace the poly V belts

EVERY 4,000 OPERATING HOURS

- Clean the main radiator of the exhaust gas recirculation (ECR) to be performed by trained technicians.

Select the recommended viscosity of oil depending on the ambient temperature at which the remote engine will be operated.

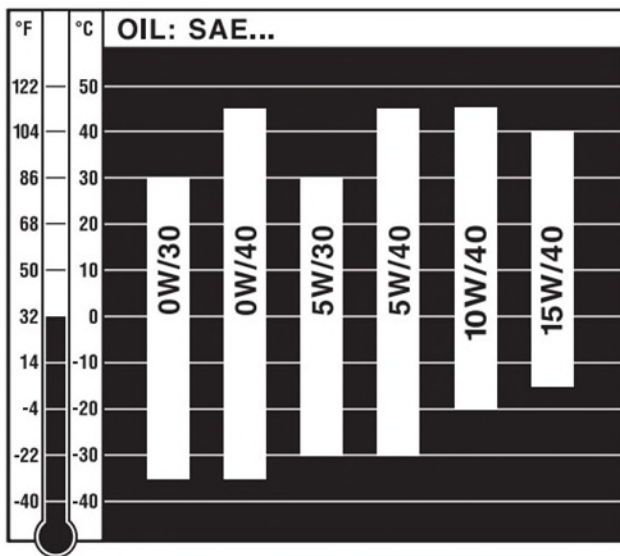

The recommended oil is ACEA E9 for engines with diesel oxidation catalyst (DOC).

The recommended oil is ACEA E6, E7 or E9 for engines without DOC.

CAUTION

UNSUITABLE ENGINE OIL CONSIDERABLY REDUCES ENGINE SERVICE LIFE. ONLY USE THE RECOMMENDED OIL WITH THE CORRECT VISCOSITY.

The recommended remote engine coolant is Mitan Alpine C40, Alpine C12+. Alternate coolants can be found in the Hatz manual (see web link to the manual in section two).

WINTERIZING/FREEZE PREVENTION

Frozen water inside of the system can lead to considerable damage. To prevent damage please consider the following:

- Air Compressor Tank – Drain the air compressor tank as much as possible.

Section 5

Schematics

Schematics may be found on the Curry Supply Company product support web page. Click the link below for quick access.

<https://currysupply.com/product-support/>

SECTION 6

Troubleshooting

PROBLEM	POSSIBLE CAUSE	REMEDIES
The compartment key will not insert into the lock.	Shield is blocking insertion of the key.	Slide shield out of the way with the tip of the key while pushing the key into the lock.
	The lock is full of ice.	Spray lock with de-ice spray.
	The key is the wrong one for the lock.	Use the correct key.
No response from hydraulic controls	The remote engine is not running.	Start the engine.
	Low hydraulic oil.	Add hydraulic oil.
	Relief valve is set too low.	Call Curry Supply Company for service 800.345.2829.
	Pinched pressure or return hydraulic line.	Repair or replace.
	Defective hydraulic pump.	Call Curry Supply Company for service 800.345.2829.
	Pressure compensated pump set too low.	Call Curry Supply Company for service 800.345.2829.
The hydraulic system is overheating.	The main system relief valve is set too low or is open because of contamination.	Call Curry Supply Company for service 800.345.2829.
	The hydraulic system operating pressure is too high.	Call Curry Supply Company for service 800.345.2829.

Slow hydraulic operations.	Valve spools are not fully open.	Call Curry Supply Company for service 800.345.2829.
	Oil is too heavy or cold.	Replace oil to correct viscosity for operating range temperature.
	Low hydraulic oil.	Add oil.
	System operating pressure or main system relief set too low.	Call Curry Supply Company for service 800.345.2829.
	Dirt or foreign matter in hydraulic system, filters valves, etc....	Call Curry Supply Company for service 800.345.2829.
	Pinched pressure or return hydraulic line.	Repair or replace.
	Excessive leakage in pump or control valve due to wear.	Call Curry Supply Company for service 800.345.2829.
Diaphragm pump cycles at stall or fails to hold pressure at stall. Diaphragm pump will not cycle, or cycles once and stops.	Worn check valve balls, seats or O-rings.	Replace.
	Air valve is stuck or dirty.	Disassemble and clean air valve. Use filtered air.
	Check valve ball severely worn and wedged in seat or manifold.	Replace ball and seat.
	Dispensing valve clogged.	Relieve pressure and clear valve.
Diaphragm Pump operates erratically.	Clogged suction line.	Clean or replace.
	Sticky or leaking balls.	Clean or replace.
	Diaphragm ruptured.	Replace.
	Restricted exhaust.	Remove restriction.

19-Feb-25

Air bubbles in hydraulic fluid from the diaphragm pump.	Suction line is loose.	Tighten.
	Diaphragm is ruptured.	Replace.
	Loose inlet manifold, damaged seal between manifold and seat, damaged O-rings.	Tighten manifold bolts or replace seats or O-rings.
	Loose diaphragm shaft bolt.	Tighten or replace.
	Damaged O-ring.	Replace.
Dispensing meter display does not wake up or displays unintelligent characters.	Electronic control is malfunctioning.	Replace electronic control.
	Batteries are depleted within the meter unit.	Replace battery.
Slow or no fluid flow.	Strainer within dispensing meter unit clogged.	Clean or replace strainer.
	Pump pressure is low.	Increase pump pressure.
	Shut off valve is not fully open.	Fully open shut off valve.
	Foreign material is jammed in the meter element.	Call Curry Supply Company for service 800.345.2829.

SECTION 7

Warranty & Proprietary Information

Curry Supply Company warrants products designed and manufactured by Curry Supply Company to be free from defects in material and workmanship under proper use and maintenance. Products must be installed and operated in accordance with Curry Supply’s written instructions and capacities. All warranty periods will begin on the in-service date as defined in this document. This warranty shall cover the following Curry Supply Products:

	1 Year	2 Years	Variable
On Road Water / Flatbed / Crash Attenuator / Lube Skid			
Curry Manufactured Components		✓	
Paint Coverage on Curry Manufactured Parts	✓		
Parts	✓		
Repair Labor	✓		
Off Road / Dump / Industrial Carrier / Vacuum / Winch / Railroad			
Tank	✓		
Tank Exterior Paint Coverage	✓		
Parts	✓		
Repair Labor	✓		
Mechanics			
Body (Refer to Manufacture Warranty)			✓
Crane (Refer to Manufacture Warranty))			✓
Paint Coverage (Refer to Manufacture Warranty)			✓
Parts (Refer to Manufacture Warranty)			✓
Repair Labor (Refer to Manufacture Warranty)			✓
Lube			
Body (Refer to Manufacture Warranty)	✓		
Tanks (Refer to Manufacture Warranty)			✓
Parts	✓		
Repair Labor	✓		
Paint Coverage	✓		
Utility Lift			
Body (Refer to Manufacture Warranty)			✓
Lift (Axion)			✓
Parts	✓		
Repair Labor	✓		
Body Paint Coverage	✓		



19-Feb-25

Definitions

Curry Supply Manufactured Components/Structures – Includes any structural weldment or load bearing support structure manufactured by Curry Supply Company.

Rust Through on Curry Supply Components/Structures – Rust Through is defined as a hole in the metal caused by corrosion. Excluded is corrosion caused by external caustics, including but not limited to improper cleaning material, road salt and other chemicals left on the structure for extended periods of time.

Paint Coverage on Curry Supply Manufactured Parts – Curry Supply guarantees that exterior paint will not fail in terms of adhesion, blistering or unreasonable loss of color or gloss for a 1-year period. Excluded is damage such as chips, dents, scratches, tank interior coating, and corrosion due to caustic chemicals (e.g. Brine Solution / Leachate) and dirt build-up. Regular cleaning and maintenance of the product to remove external factors is expected to keep this warranty in force.

Vendor Supplied Components/Structures – Products purchased by Curry Supply from outside vendors. These items shall be covered by the warranty offered by the respective manufacturer only. Curry Supply does not obligate itself to any such warranty.

Warranty Process

Curry Supply's obligation under this warranty is limited to, and the sole remedy for any such defect shall be the repair and/or replacement (at Curry Supply's option) of the unaltered part and/or component in question. Curry Supply after-sales service personnel must be notified by telephone, email, or letter of any warranty applicable damage within fourteen (14) days of its occurrence. If possible, Curry Supply will ship the replacement part within 24 hours of notification by the most economical, yet expedient, means possible. Expedited freight delivery will be at the expense of the owner.

Warranty claims must be submitted and shall be processed in accordance with Curry Supply's established warranty claim procedure. Curry Supply after-sales service personnel must be contacted prior to any warranty claim. A return materials authorization (RMA) may be issued to the claiming party prior to the return of warranty parts. Parts returned without prior authorization will not be recognized for warranty consideration. All damaged parts must be returned to Curry Supply freight prepaid; freight collect returns will be refused. Freight reimbursement of returned parts will be considered as part of the warranty claim.



Warranty Repair

Warranty service will be performed by any Curry Supply factory, Curry Supply mobile technician, Curry Supply authorized service partner, or by the affected owner. At the time of requesting warranty service, Curry Supply after-sales service personnel will verify date of delivery of the product. The owner shall be obligated to pay for any overtime labor requested of the servicing company by the owner, any field service call charges, and any towing and/or transportation charges associated with moving the equipment to the designated repair/service provider.

All obligations of Curry Supply and its service providers shall be voided if someone other than an authorized Curry Supply provider performs other than routine maintenance service without prior written or verbal approval from Curry Supply. In the case repair work is performed on a Curry Supply-manufactured product, original Curry Supply parts must be used to keep the warranty in force. The warranty may also be voided if the product is modified or altered in any way not approved, in writing, by Curry Supply.

Warranty Limitations/Responsibilities

This warranty covers only defective material and workmanship. It does not cover depreciation or damage caused by normal wear and tear, accident, mishap, untrained operators, or improper or unintended use. The owner has the obligation of performing routine care and maintenance duties as stated in Curry Supply's written instructions, recommendations, and specifications. Any damage resulting from owner/operator failure to perform such duties shall void the coverage of this warranty. The owner will pay the cost of labor and supplies associated with routine maintenance.

The only remedies the owner has in connection with the breach or performance of any warranty on the Curry Supply product specified are those set above. In no event will Curry Supply, or any company affiliated with Curry Supply, be liable for business interruptions, costs of delay, or for any special, indirect, incidental, or consequential costs or damages. Such costs may include, but are not limited to, loss of time, loss of revenue, loss of use, wages, salaries, commissions, lodging, meals, towing, hydraulic fluid, or any other incidental cost.

All products purchased by Curry Supply from outside vendors shall be covered by the warranty offered by that respective manufacturer only. Curry Supply does not participate in, or obligate itself to, any such warranty.

19-Feb-25

Curry Supply reserves the right to make changes in design or improvement upon its products without imposing upon itself the same upon its products theretofore manufactured.

This warranty will apply to all Curry Supply manufactured components/structures and upfit workmanship shipped from Curry Supply's factory. The warranty is for the use of the original owner only and is not transferable without prior written permission from Curry Supply.

Curry Supply After-Sales Contact Information:

Phone: (800) 345-2829

Email: service@currysupply.com

Mailing Address: 1477 DeGol Industrial Drive, Hollidaysburg, PA 16648

THIS WARRANTY IS EXPRESSLY IN LIEU OF ANY OTHER WARRANTIES, EXPRESS OR IMPLIED, INCLUDING ANY WARRANTY OF MERCHANTABILITY OR FITNESS FOR A PARTICULAR PURPOSE. REMEDIES UNDER THIS WARRANTY ARE LIMITED TO THE PROVISION OF MATERIAL AND SERVICES, AS SPECIFIED HEREIN. CURRY SUPPLY COMPANY IS NOT RESPONSIBLE FOR INCIDENTAL OR CONSEQUENTIAL DAMAGES.

EXCEPT AS STATED, THERE IS NO WARRANTY, EXPRESS OR IMPLIED, IN CONNECTION WITH THE DESIGN, MANUFACTURE, SALE OR USE OF THE MACHINERY, ACCESSORIES, EQUIPMENT AND PARTS SOLD BY CURRY SUPPLY CO. CURRY SUPPLY COMPANY'S LIABILITY ON ITS WARRANTY SHALL IN NO EVENT EXCEED THE COST OF THE ITEM OF SALE.



For technical help or parts, please have the serial number available and call our customer service 800.345.2829