

Lube Trucks Van

Schematics

VMAC Control Components Overview SCH1-1	Page 2
VMAC Control Module SCH2-1	Page 3
VMAC Interface Panel SCH3-1	Page 4
VMAC Digital Throttle Control SCH4-1	Page 5
VMAC WHASP Tank Mechanical Pressure Switch SCH5-1	Page 6
VMAC Electrical Schematic 1 SCH6-1	Page 7
VMAC Electrical Schematic 2 SCH6-2	Page 8

CAUTION

PLEASE CONTACT CURRY SUPPLY BEFORE ATTEMPTING ANY CHANGES TO THE ELECTRICAL SYSTEMS. DOING SO MAY CAUSE EQUIPMENT DAMAGE OR VOID WARRANTY.

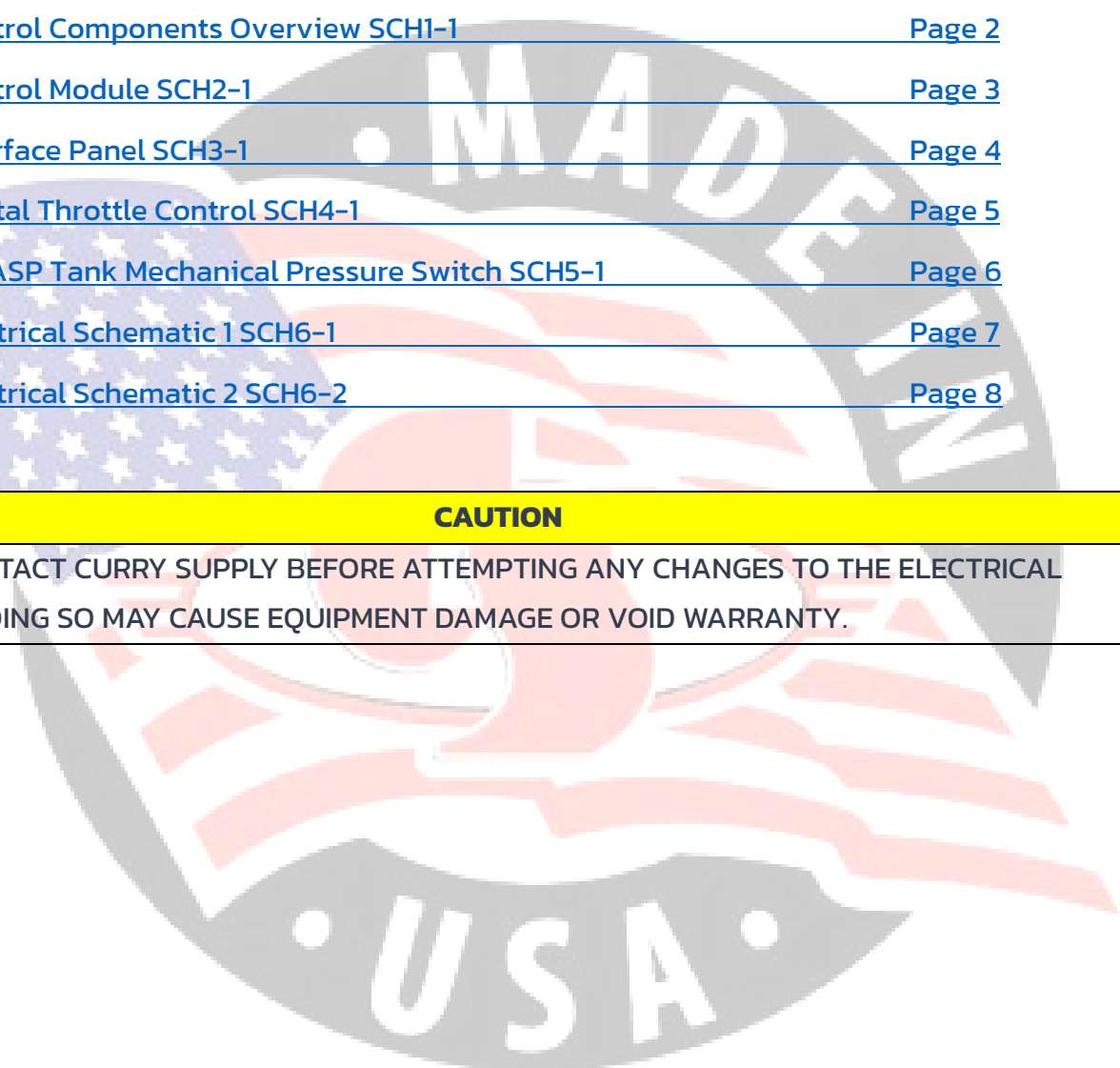

Control Components Overview

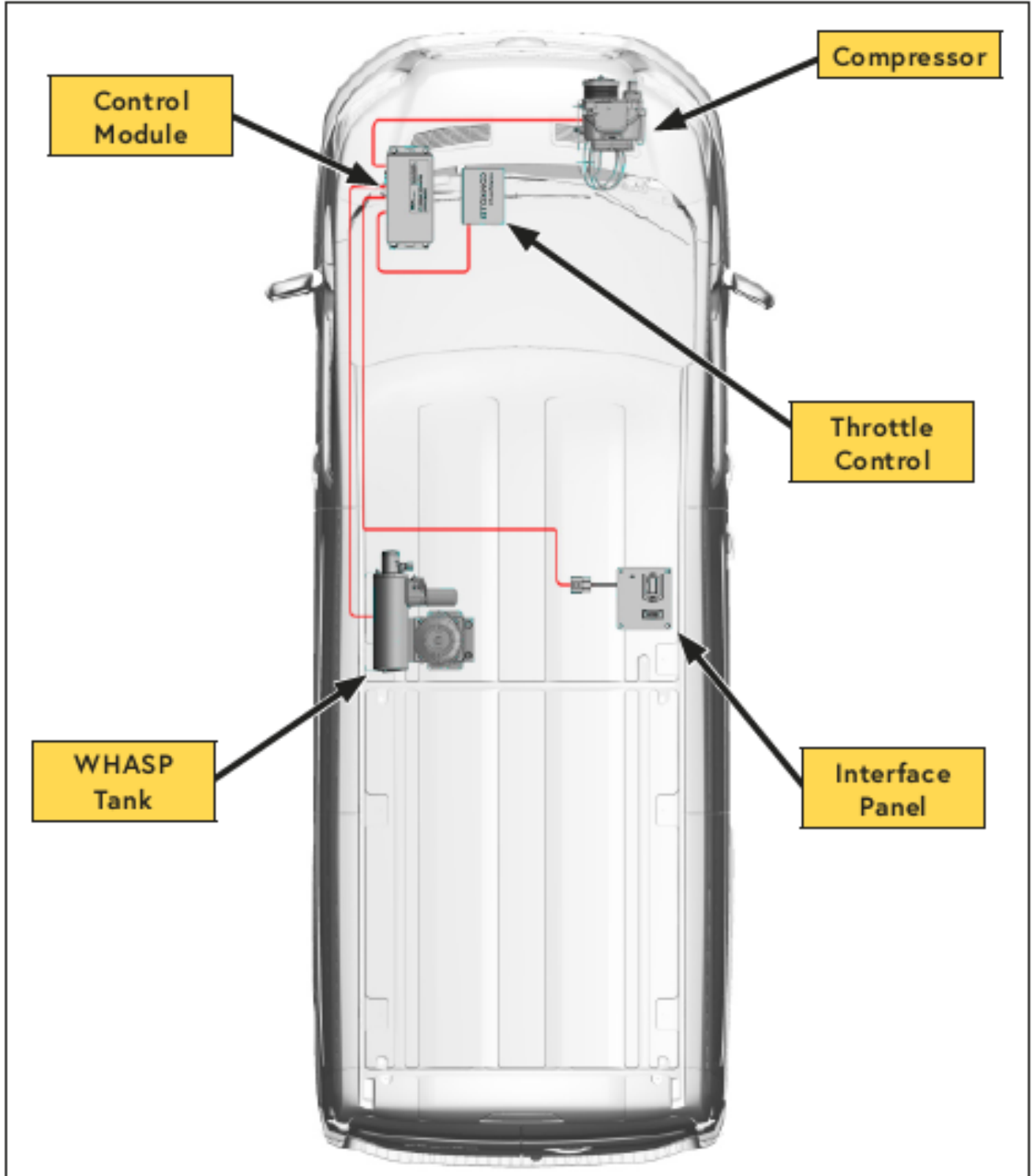

Figure 50 — General component overview
(Actual installation locations may vary)

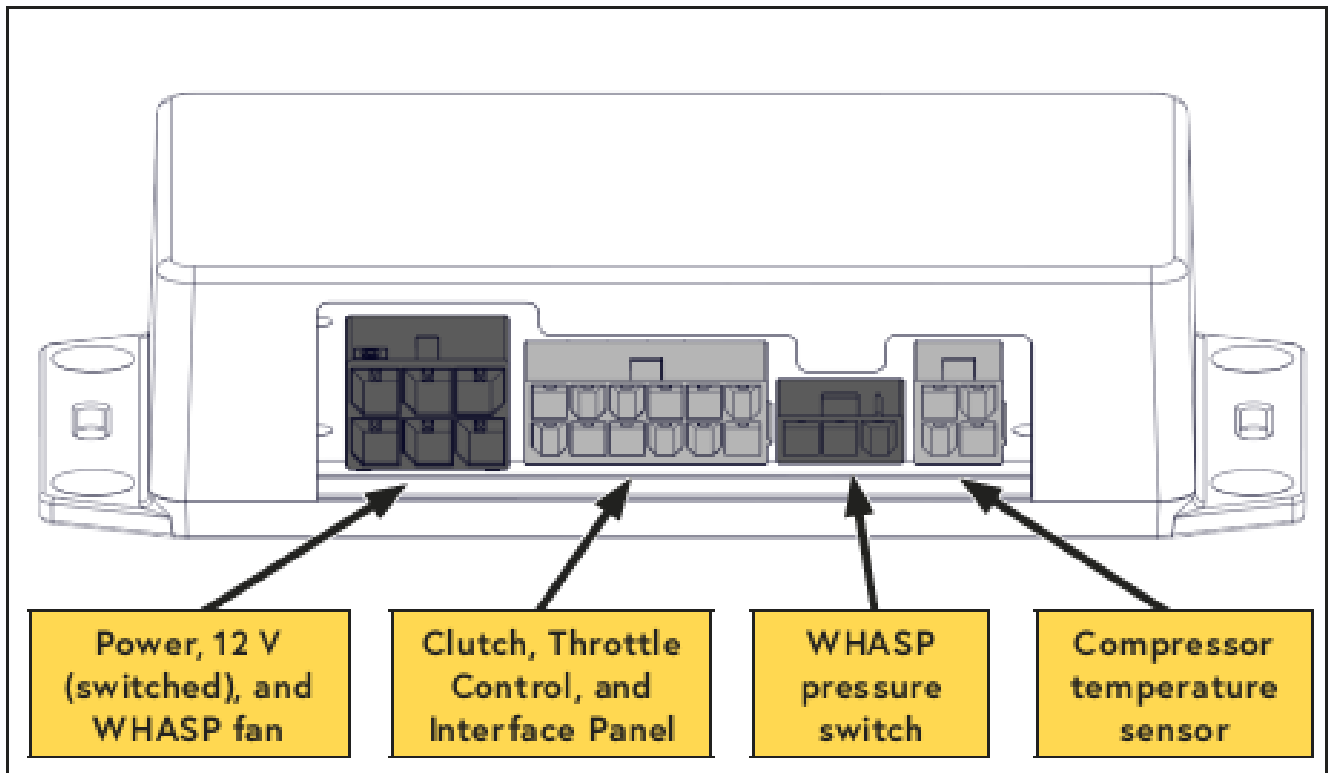

Figure 51 — Control Module

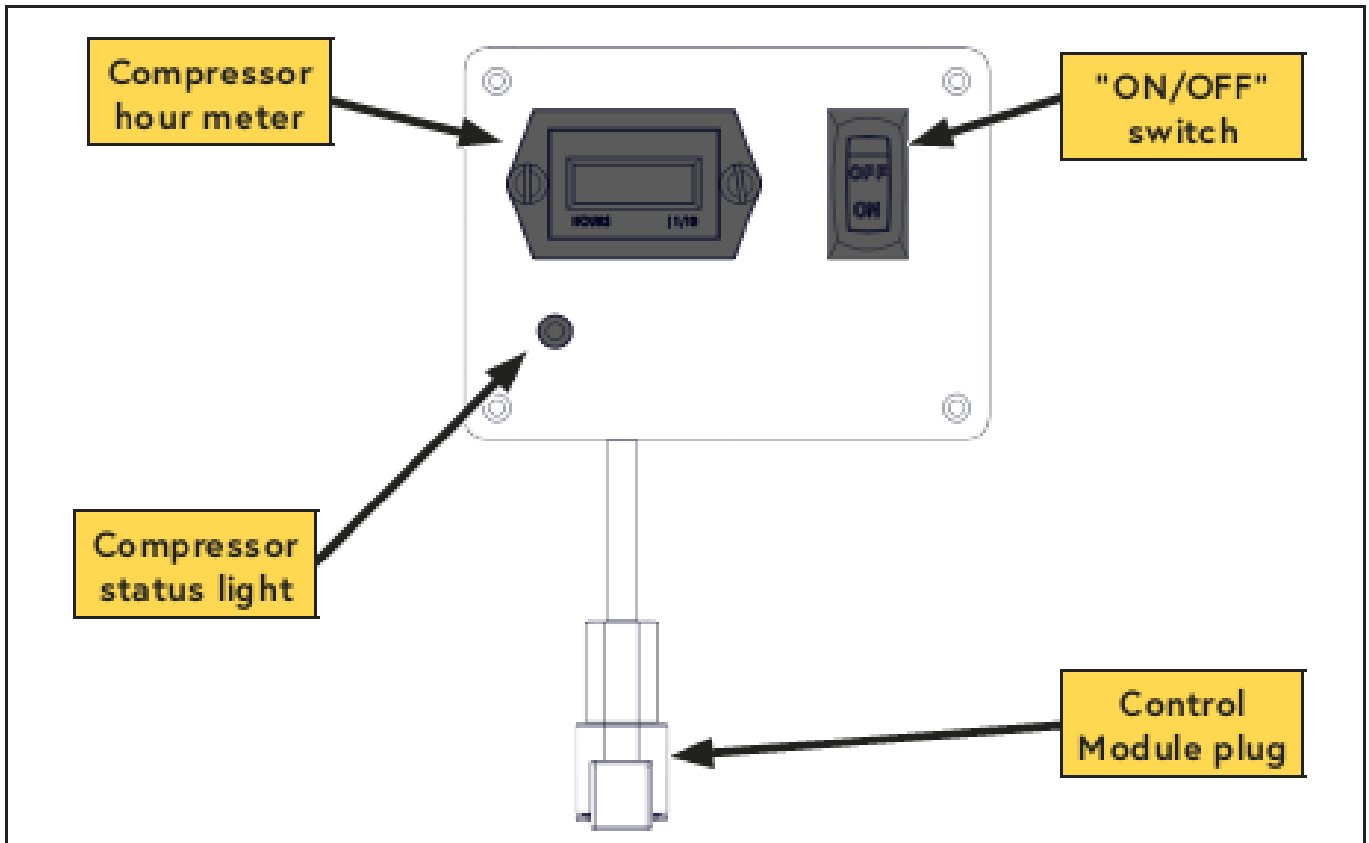

Figure 52 — Interface Panel

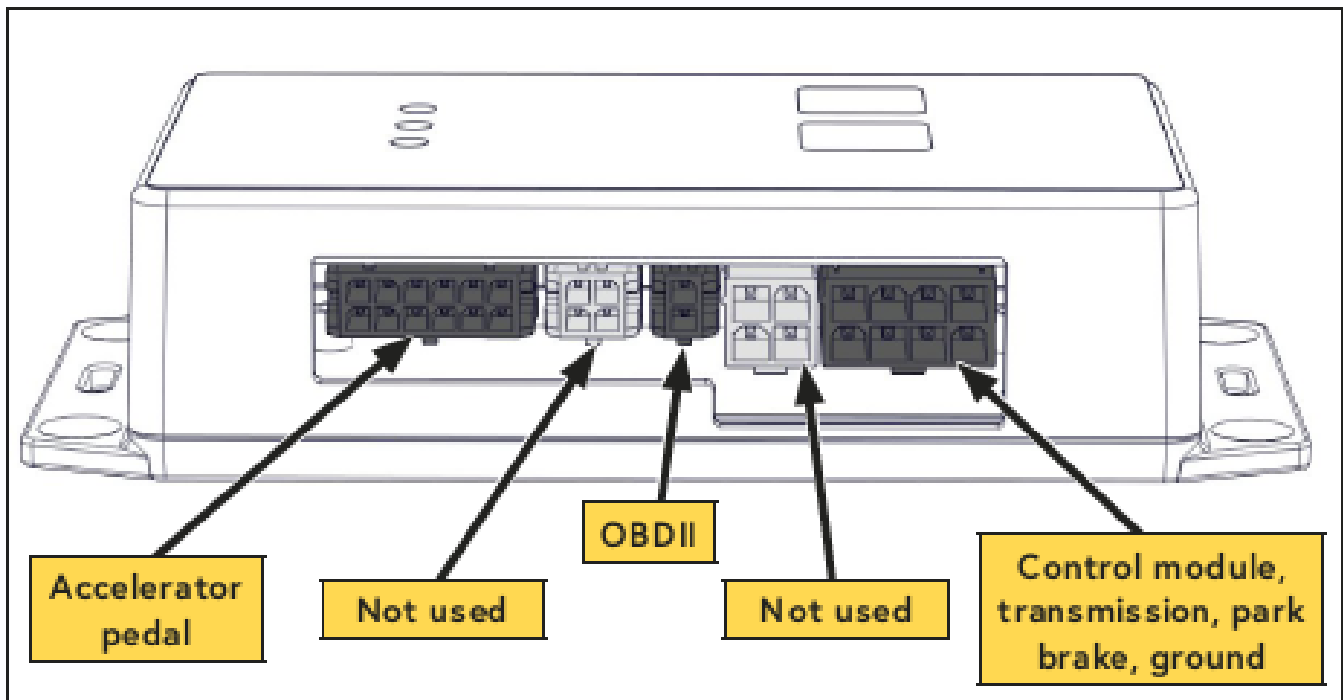

Figure 53 — VMAC digital Throttle Control

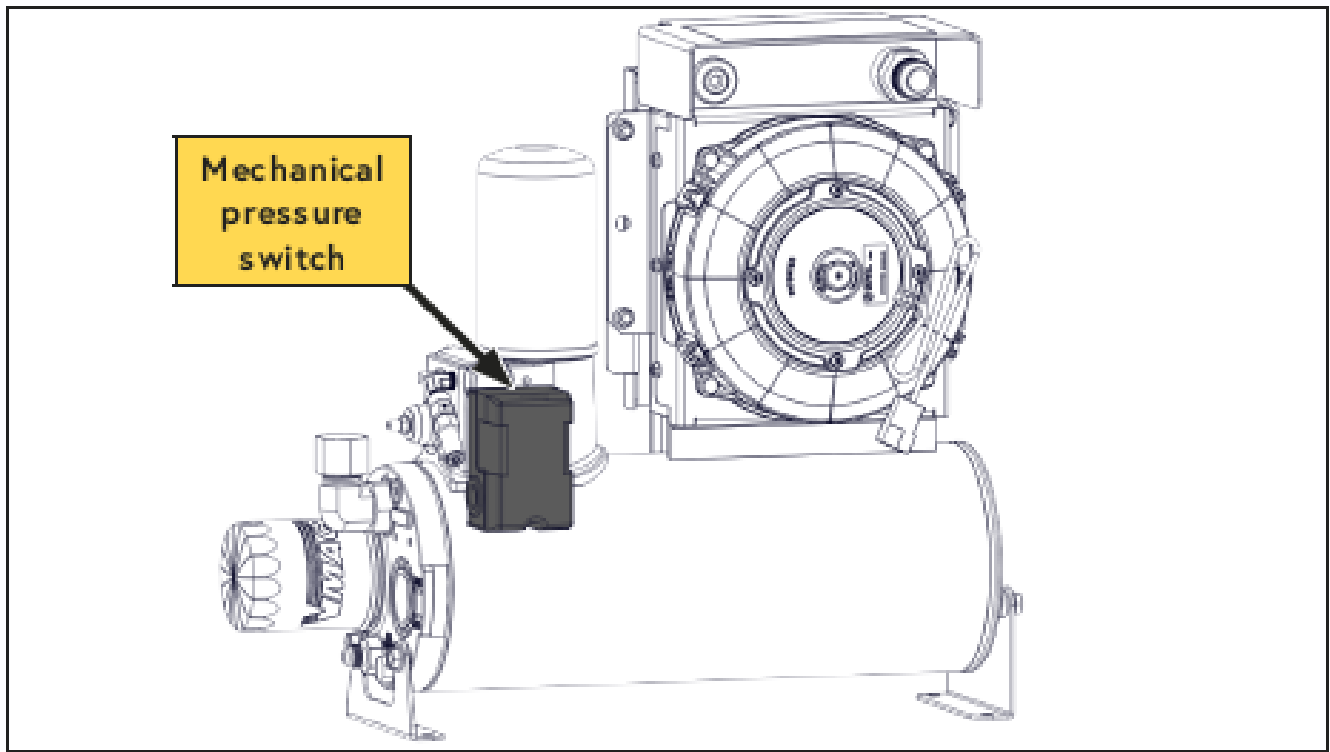

Figure 54 — WHASP Tank pressure switch

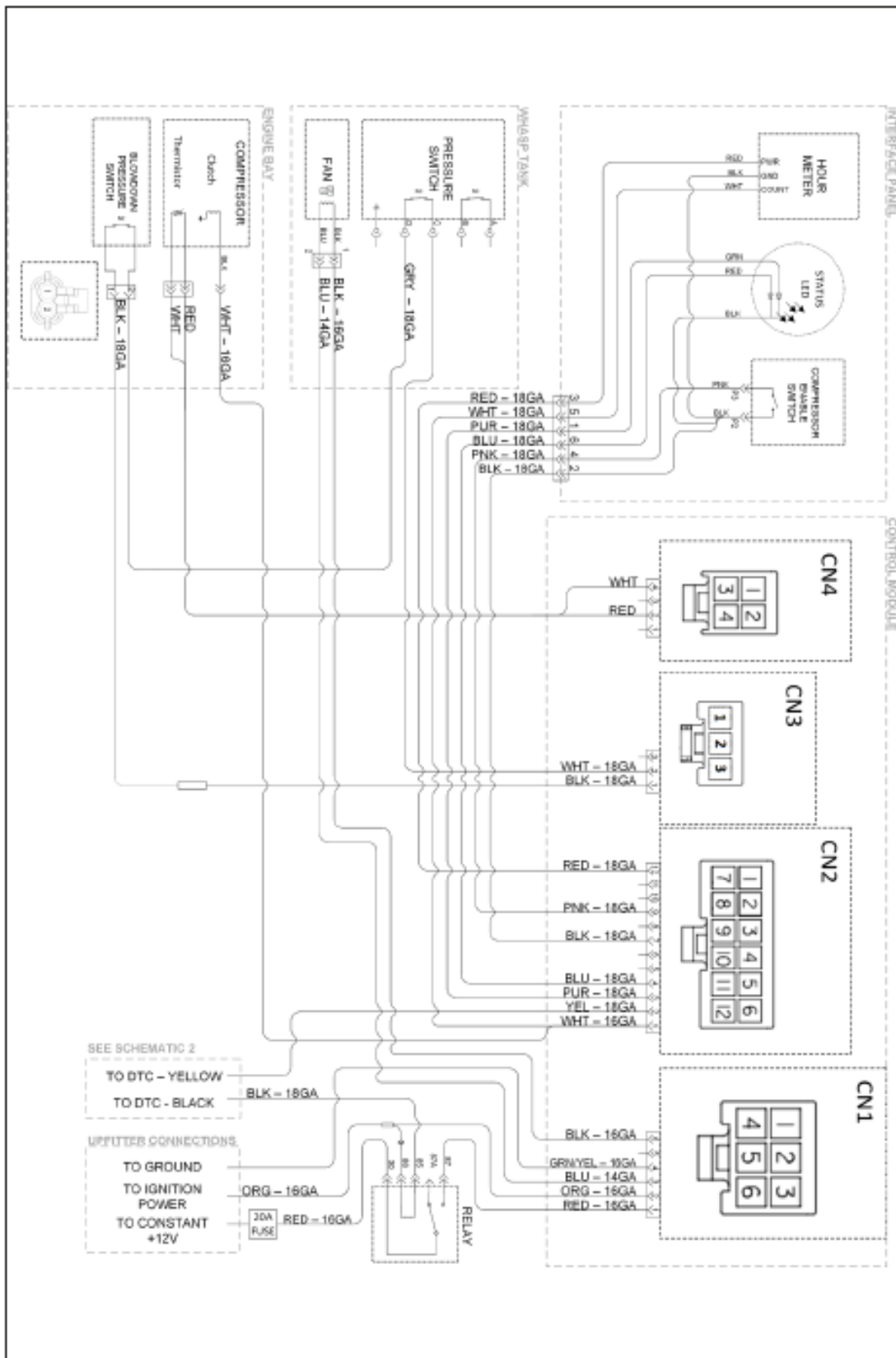

Figure 55 — Electrical schematic 1

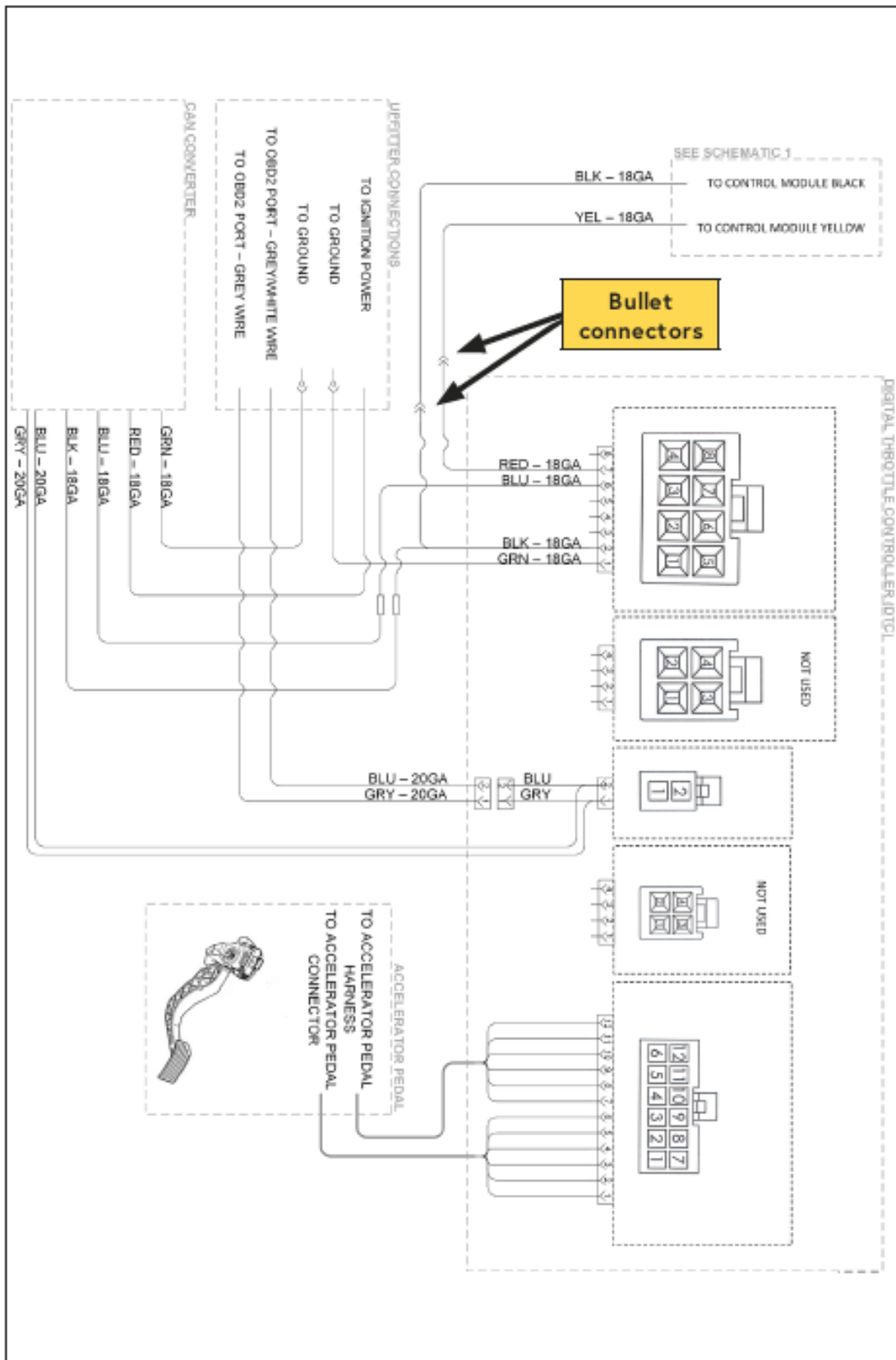

Figure 56 — Electrical schematic 2