



Operator Manual

Aerial Lift Truck



Curry Supply Co., 1477 Degol Industrial Drive, Hollidaysburg, PA 16648

YOUR JOBS. OUR TRUCKS.



TABLE OF CONTENTS

Sections

Introduction & Safety Messages.....	3
System Descriptions.....	6
Normal Operation.....	8
Maintenance & Lubrication.....	16
Schematics.....	19
Troubleshooting.....	32
Warranty & Proprietary Information.....	36

SECTION 1

Introduction & Safety Messages

CONTACT US

Curry Supply Company

1477 Degol Industrial Drive, Hollidaysburg, PA 16648

service@currysupply.com CurrySupply.com

Parts 800.567.5127

Warranty Service 800.345.2829

MANUAL USAGE

This Operators Manual contains information to safely operate more than (1) configuration of "Curry Supply Company Aerial Lift Truck". The parts shown may not reflect the exact configuration on your truck. "Custom" style trucks may have parts not listed. If your system is not covered in this manual, please contact Curry Supply Co. Support at 800.345.2829 or service@currysupply.com.

All personnel working on or operating the machine must become familiar with the following safety messages.

Due to the nature of these processes, ensure that all safety information, warnings, and instructions are read and understood before any operation or maintenance procedures are performed.

This manual does not supersede any local, state, or federal laws.

WARNING, CAUTION, AND NOTES

The following definitions are found throughout this manual and apply as follows:

WARNING

OPERATING PROCEDURES AND TECHNIQUES COULD RESULT IN PERSONAL INJURY OR LOSS OF LIFE IF NOT FOLLOWED CORRECTLY.

CAUTION

OPERATING PROCEDURES AND TECHNIQUES WHICH COULD RESULT IN DAMAGE TO EQUIPMENT IF NOT FOLLOWED CORRECTLY.

NOTE

OPERATING PROCEDURES AND TECHNIQUES THAT ARE CONSIDERED ESSENTIAL TO EMPHASIZE.

SAFETY MESSAGES

The most common risks when using aerial lifts are getting shocked by power lines and falling due to equipment failure or unsafe actions by the operator.

20-Dec-24

There are different decals placed around the truck. Make sure to replace them if they are hard to read or start to come off. Everyone working on or using the truck should be familiar with this manual and all the decals.

 CAUTION 
CHECK THE PTO FOR LEAKS AND LOOSE MOUNTING HARDWARE (STUDS, CAP SCREWS, NUTS). CHECK WITHIN THE FIRST WEEK OF USE, MONTHLY THEREAFTER, OR EVERY 100 HOURS OF OPERATION WHICHEVER COMES FIRST.
TA0-047

CAUTION
NEVER EXCEED THE WEIGHT CAPACITY OF THE LIFT.



CAUTION
DO NOT MAKE ANY MODIFICATIONS TO THE LIFT OR ITS SAFETY FEATURES.

CAUTION
NEVER USE EQUIPMENT IF IT MAKES UNUSUAL NOISES, HAS VIBRATIONS, OR FAILS TO OPERATE FREELY.



WARNING
THE VEHICLE IS EQUIPPED WITH A BACK-UP ALARM. ALARM MUST SOUND WHEN OPERATING THIS VEHICLE IN REVERSE.

CAUTION
DO NOT MOVE VEHICLE UNLESS THE LIFT IS LATCHED AND STOWED INTO POSITION.

WARNING
ALWAYS CHOCK WHEELS IMMEDIATELY UPON EXITING THE VEHICLE.



CAUTION
ADVERSE WEATHER CONDITIONS CAN CAUSE EQUIPMENT DAMAGE. WHENEVER POSSIBLE, PERFORM MAINTENANCE INDOORS.

NOTE
ALL REPAIRS OF LIFTS SHOULD BE DONE BY AN AUTHORIZED DISTRIBUTOR WHO KNOWS HOW THEY WORK AND HOW TO KEEP THEM SAFE. ANY REPLACEMENT PARTS MUST BE OF ORIGINAL QUALITY, AND ALL SAFETY AND OPERATION LABELS MUST BE ATTACHED AND EASY TO READ.

WARNING
CONTACT WITH LIVE ELECTRICAL CIRCUITS COULD DAMAGE EQUIPMENT OR CAUSE INJURY.



WARNING

DO NOT WALK ON TOP OF THE VEHICLE. FALLING FROM VEHICLE CAN RESULT IN SERIOUS INJURY.



WARNING

IMPROPER USE OF EQUIPMENT COULD CAUSE SERIOUS INJURY OR DEATH. PLEASE READ AND UNDERSTAND ALL INSTRUCTIONS.



WARNING

DO NOT OPERATE THE UNIT WHILE INTOXICATED OR EXTREMELY EXHAUSTED.



WARNING

MOVING PARTS CAN CRUSH AND CUT. KEEP HANDS, FEET, HAIR, AND LOOSE CLOTHING AWAY FROM MOVING PARTS.



WARNING

WHEN OPERATING OR WORKING ON THE UNIT, KEEP HANDS AND BODY PARTS CLEAR OF PINCH POINTS.



WARNING

ALWAYS WEAR THE PROPER PPE WHILE OPERATING THE UNIT.



WARNING

ALWAYS WEAR YOUR SAFETY BELT WHILE DRIVING THE VEHICLE. IF VEHICLE TIPS, STAY BUCKLED AND INSIDE OF CAB AREA.



SECTION 2

System Descriptions

SIDE VIEW OF TRUCK



REAR VIEW OF TRUCK



FRONT VIEW OF TRUCK



TOOL STORAGE

All Curry Supply Company Aerial Lift trucks have tool storage on both sides. These storage areas come with locks. The type, size, and location of the storage bays can be different for each truck.

AERIAL LIFT

The most common aerial lift installed is the Axion AT40. Other offered lifts include Elliott Equipment, Dur-A-Lift, Posi Plus, and Stellar Industries. This manual will focus mostly on the Axion AT40. More information can be found in the AT40 Operator Manual that came with the truck or on Axion's website at <https://us.axionlift.com/>. Information about other lifts can be found at the following links:

<https://elliottequip.com/>

<https://dur-a-lift.com/>

<https://www.posiplus.com/en/>

<https://www.stellarindustries.com/>

Insulated lifts are offered for work around power lines. The booms of these lifts are typically manufactured from fiberglass. Refer to the manufacturer operator's manual to determine if the lift is insulated.

OUTRIGGER/STABILIZER

Some Aerial Lift trucks have outriggers (stabilizers). They help keep the truck stable and prevent it from rolling over. All trucks are tested and rated for their ability to prevent rolling. Two different styles offered are the "A" frame and the "H" frame.

Torsion Bar

For trucks that do not have an outrigger, torsion bars are installed. Torsion bar stabilizers are torque tube devices that attach to the rear axle to provide stability.

A-Frame Outrigger

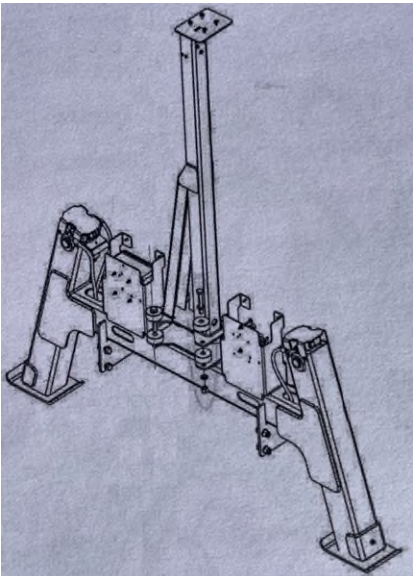

H-Frame Outrigger

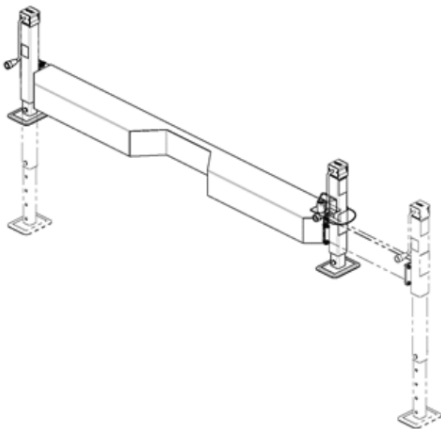

SECTION 3

Normal Operation

This section provides the vehicle operator with step-by-step operating procedures for the installed systems.

Prior to any operation, please perform a walk around inspection of the vehicle. Check specifically for leaks and broken hoses.

TOOL STORAGE

You can unlock the tool storage doors using either the key or the locking bar. The key locks or unlocks each door individually, while the locking bar locks or unlocks all the doors on that side at once.

1. To unlock all the bays on one side, pull out on the locking bar. Push in to lock.



2. To unlock one storage bay at a time, use the key. Each lock has a shield to protect it. To unlock it, slide the shield to the side with the tip of the key while pushing the key into the lock.



- To open the door, pull the handle toward you. The latch and handle have springs, so you don't need to use the handle to close the door, it can be pushed shut.



OUTRIGGERS/STABILIZERS (If Installed)

The following operations show the A-Frame functionality. Information for the H-Frame can be found at the links listed in Section 2 of this manual.

NOTE

The aerial lift will not run if the outriggers/stabilizers are not fully engaged with the ground.

- Make sure the truck is parked in a safe place with an acceptable incline. You can check this using the level gauge located just outside the driver's side door. The ball must be within the green shaded area.



- Always use the emergency brake, which is by your left knee when you're in the driver's seat. A message will show up on the console to let you know if the emergency brake is on or off.



- Press the buttons on the overhead console to turn on the strobe lights and PTO. The truck will go to high idle and the PTO indicator light will turn on (located next to the emergency brake switch).



20-Dec-24

- Place a chock behind one front wheel and in front of one rear wheel on the side of the truck where you'll be working.

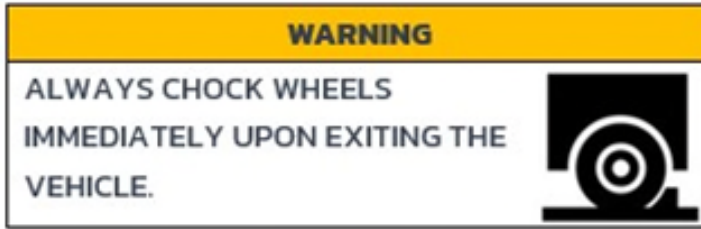

- Make sure there are no obstacles where the feet of the outriggers touch the ground.



- On the driver's side, press the top switch down to turn off the lift while turning on the outrigger.



- Press the toggle button to extend the outrigger until the weight is off the springs of the truck. Do NOT lift the tires off the ground. Repeat on the passenger side.



8. Make sure the ball in the level indicator is in the green shaded area. If it isn't, adjust the outriggers. If the truck still won't level and the tires lift off the ground, you need to move the truck to a better spot.



AERIAL LIFT AXION AT40

The operations in this manual are for the Axion AT40 aerial lift. You can find operation manuals for other lifts at the links below:

<https://elliottequip.com/>

<https://dur-a-lift.com/>

<https://www.posiplus.com/en/>

<https://www.stellarindustries.com/>

Axion AT40 General Specifications

Working Height	45 Ft.
Ground to bottom of platform	40 Ft.
Maximum side reach	28.5 Ft.
Stowed Tavel Height	9 Ft.
Platform Capacity	400 lb. / 450 lb.
Platform dimensions	24x30x42 in.
Rotation	Infinite 360°
Max side reach w/180° platform rotator	26.6 Ft.
Boom Extension	8.2 Ft.

WARNING

WHEN TOOLS OR EQUIPMENT ARE INCLUDED WITH THE OPERATOR IN THE PLATFORM BUCKET THE TOTAL WEIGHT MUST NOT EXCEED THE RATED PLATFORM CAPACITY. A PLACARD IS LOCATED AT THE TURNTABLE WITH THE RATED PLATFORM CAPACITY FOR YOUR SPECIFIC UNIT.

1. Make sure the truck is parked in a safe place with an acceptable incline. You can check this using the level gauge located just outside the driver's side door. The ball must be within the green shaded area.



20-Dec-24

2. Always use the emergency brake, located by your left knee in the driver's seat. A message will appear on the console to tell you if the emergency brake is on or off.



3. Press the buttons on the overhead console to turn on the strobe lights and PTO. The truck will go to high idle and the PTO indicator light will turn on (located next to the emergency brake switch).



4. Place a chock behind one front wheel and in front of one rear wheel on the side of the truck where you'll be working.

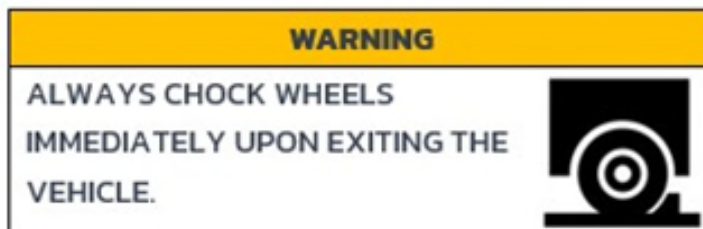

5. If outriggers/stabilizers are installed, follow the steps in the OUTRIGGER/STABILIZER section to extend them.



NOTE

The aerial lift will not run if the outriggers/stabilizers are not fully engaged with the ground.

6. Press the top toggle switch to the lift position. Remember to do this before climbing into the bucket because this is the only switch to activate the lift.



7. Check the level of the lift's hydraulic fluid.
The gauge is located on the base of the lift.
Don't operate the lift if the fluid level is not between the maximum and minimum indicators.



8. Unlatch the stow strap.



9. Pull the controls lever (red handle) toward you to operate lift using the bucket mounted control panel.



10. Put safety harness on, climb into the bucket and tether to the bucket.



11. Use the bucket control panel and move to the work area.

PLATFORM BUCKET CONTROL PANEL

If all power is lost, turn emergency valve counterclockwise and use the bucket control panel to lower yourself to the ground.

Push to increase the truck engine idle. May need to increase for tool usage.

Push and hold to activate emergency PTO. Must hold it in while operating controls. Do not operate for more than 3 continuous minutes.

Emergency Stop
Push to shut off all power to the truck.

Push to restart the truck engine.

Push to use the hydraulic tool ports. Tool hose must be connected prior to activation.

Push up to rotate the bucket clockwise.
Pull back to rotate the bucket counter clockwise.

The bucket is self leveling. If needed, you can override this feature for extreme circumstances.

PULL THE TRIGGER AND HOLD TO OPERATE
Push & pull handle to raise and lower the UPPER Boom.
Turn the handle clockwise & counter clock wise to raise and lower the LOWER Boom.
Slide the handle forward and back to extend and retract the Boom EXTENSION.

12. Stow the lift in the following order:
 - a. Retract the extension boom.
 - b. Center the lift to the truck.
 - c. Lower the lower boom to the stow pedestal.
 - d. Lower the upper boom.
 - e. Latch the stow strap.

EMERGENCY BACK UP ELECTRIC PTO

If the truck engine won't run, the lift may be moved with the backup PTO. It runs directly from the trucks battery and should only be used in emergency situations.

1. Press the toggle button to the start position.
Operate the lift normally. Do not operate for more than 3 continuous minutes.



CAUTION

DO NOT OPERATE EMERGENCY BACK UP ELECTRIC PTO FOR MORE THAN 3 CONTINUOUS MINUTES.

SECTION 4

Maintenance & Lubrication

Due to numerous jobs and purposes, varying environments and climates, and importance to safety, routine maintenance is highly recommended. Regular maintenance keeps the trucks functioning correctly and at optimum efficiency. The following tasks can help prevent breakdown and keep the truck on the job when you need it most.

NOTE

FOR THE MOST ACCURATE MAINTENANCE FOR A SPECIFIC CHASSIS SYSTEM, REFER TO THE PRODUCT SPECIFIC USER MANUAL.

DAILY SAFETY MAINTENANCE

Tires – Check for proper inflation and tread depth.

Brake System – Routine inspections on brake pads and calipers for safe operation.

Lights – Check all lights are working and functioning correctly.

Fluids – Check that the engine oil, coolant, Hydraulic fluid, and wiper fluid are all at the right levels.

Hoses – Check for leaks and cracks, and make sure everything is securely fastened.

TOOL STORAGE

Daily

1. Inspect doors latch securely.
2. Push the locking bar (if installed) in and check that the doors will not open.
3. Pull the locking bar (if installed) out and check that the doors will open.
4. Insert the key into each door and turn to lock. Ensure the doors do not open.
5. Insert the key into each door and turn to unlock. Ensure the doors open.

Monthly

1. Lubricate hinges with white lithium spray lubricant.
2. Spray door locks with lock lubricant.
3. Apply white lithium grease to the locking bar (if installed).

OUTRIGGERS/STABILIZERS (If Installed)

Daily

1. Inspect the master cylinder, slave cylinder, hoses and fittings for damage, wear, or foreign objects.
2. Inspect assembly for damaged, bent, missing or rusted components.

Monthly

1. Lubricate pivots and inner tube extension with white lithium grease.

AERIAL LIFT

Specific maintenance schedules should be performed by a qualified distributor. To ensure that your lift remains operationally effective, follow the maintenance schedule as defined in the lift manufacturer’s service and installation manual.

The Axion AT40 lift specifies the following maintenance & inspection schedule:

- 30 days or 85 PTO hours after “In Service” date
- Every 3 months or 250 PTO hours
- Every 6 months or 500 PTO hours
- Periodic dielectric testing 1 to 12 months
- Every year or 1500 PTO hours
- Two year or 3000 PTO hours

The following inspections should be performed by a trained operator.

Daily

1. Check all bolts are tight.
2. Check all load supporting bolts torque seal marks are intact and show no signs of movement.
3. Check all welds for signs of fatigue, rust or cracks.
4. Check all hydraulic lines for loose connections or frayed jackets.
5. Check for leaking oil.
6. Check electrical system for damaged or loose components.
7. Check for bare electrical wires.
8. Check hydraulic oil level.

9. Operate all lift controls through the full range of motion.
10. Replace decals that are hard to read, starting to come off or missing.
11. Check the fiberglass main boom and arm for dirt that will impair the dielectric integrity of the fiberglass. Clean with lint free cloth. Refer to the manufacturer service & installation manual for the care of Fiberglass components.
12. Check for structural damage such as cracks or gouges.
13. Check that all covers are in place, secure and an in good condition.

Recommended Hydraulic Oil

Conditions	Viscosity	Temperature
Standard	22	0 – 110°F
Severe Cold	15*	-20 – 95°F
Extreme Heat	32	32 – 120°F

*Oil to meet or approach MIL-H-5606A

POWER TAKE OFF (PTO)

Upon delivery of the vehicle and initial operation, check for leaks from any location. The PTO should be serviced at the same intervals as the transmission. The transmission maintenance should be completed as recommended by the vehicle manufacturer. The PTO is part of a system that includes the drive shaft which should also be checked at the same time.

Within the first week of use, recheck the installation of the PTO. Check for leaks and



20-Dec-24

loose mounting hardware (studs, cap screws, nuts). Recheck the cable or lever connections for proper adjustment and tighten any loose connections. At regular maintenance intervals, check adjustments and lubricate moving parts, tighten and repair the connections, mounting hardware, cable, or lever linkages.

Before daily use:

- Check for any leaks.
- Check the transmission oil level.
- Check for any dents or damage to PTO or driveshaft system.

Every 100 usage hours:

- Recheck the installation of the PTO.
- Check for leaks and loose mounting hardware (studs, cap screws, nuts).
- Recheck and tighten any loose connections.
- Check adjustments and lubricate moving parts.
- Check and retighten any bolts, linkages, or mounting hardware.
- Apply anti-seize grease to output shaft.

SECTION 5

Schematics

W0005534 AT40 Elec Interlock SCH1-1	Page 20
W0006843 AT40 Elec F R Interlock SCH2-1	Page 21
W0005535 AT40 Elec SST and Back Up Pump SCH3-1	Page 22
W0006838 AT40 Elec Torsion Bar SCH4-1	Page 23
W0006839 AT40 Elec F Outrigger SCH5-1	Page 24
W0006840 AT40 Elec F R Outrigger SCH6-1	Page 25
W0006988 AT40 Elec Outrigger F SCH7-1	Page 26
W0006990 AT40 Elec Outrigger R SCH8-1	Page 27
2187-1053 AT40 Elec Ford 2023+ SCH9-1	Page 28
W0003605 AT40 Hyd-W Booms Assy SCH10-1	Page 29
W0003606 AT40 Hyd-W Chassis and Torsion Bar SCH11-1	Page 30
W0003187 AT40 Hyd-W Chassis and Outrigger SCH12-1	Page 31

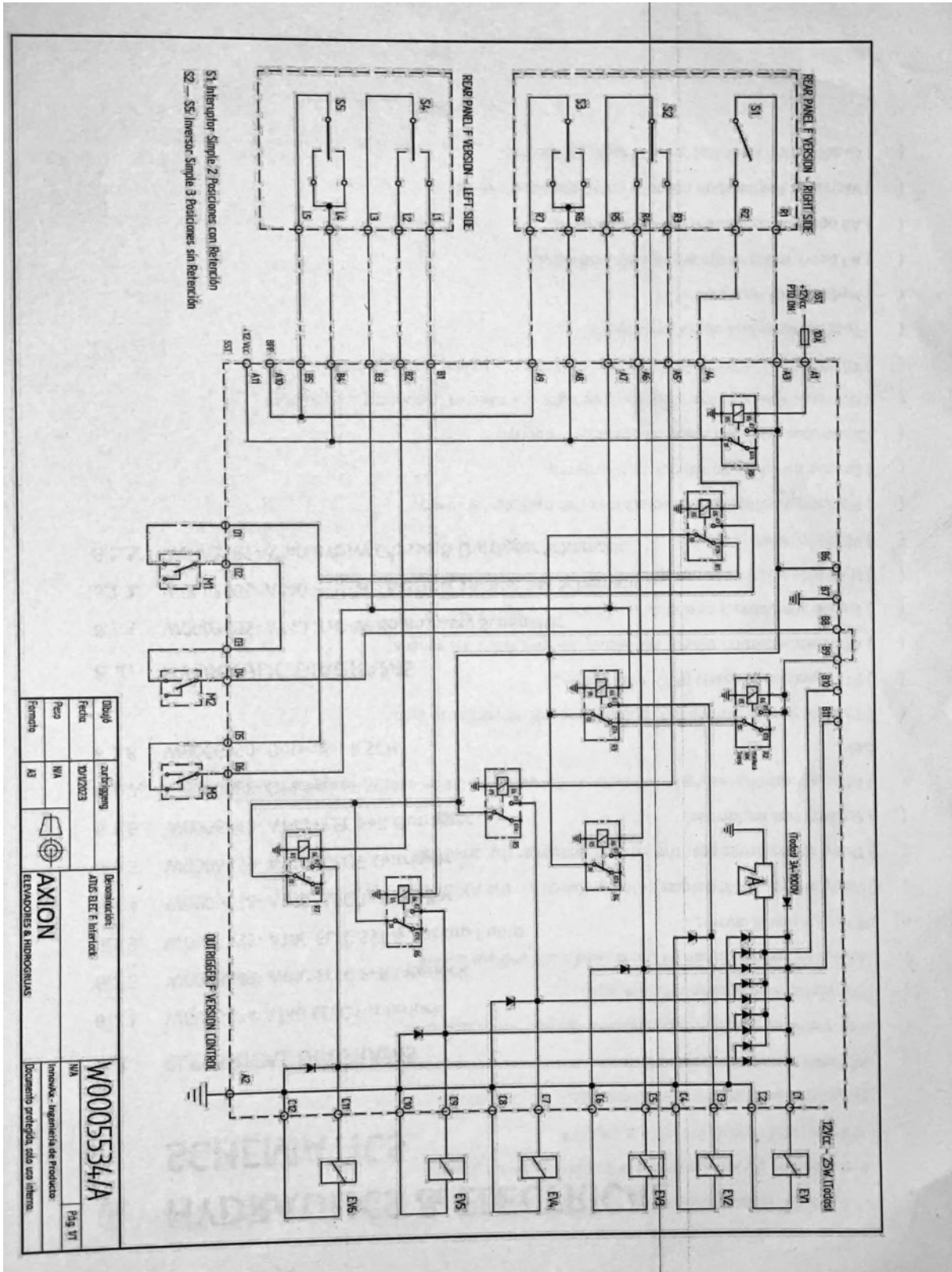

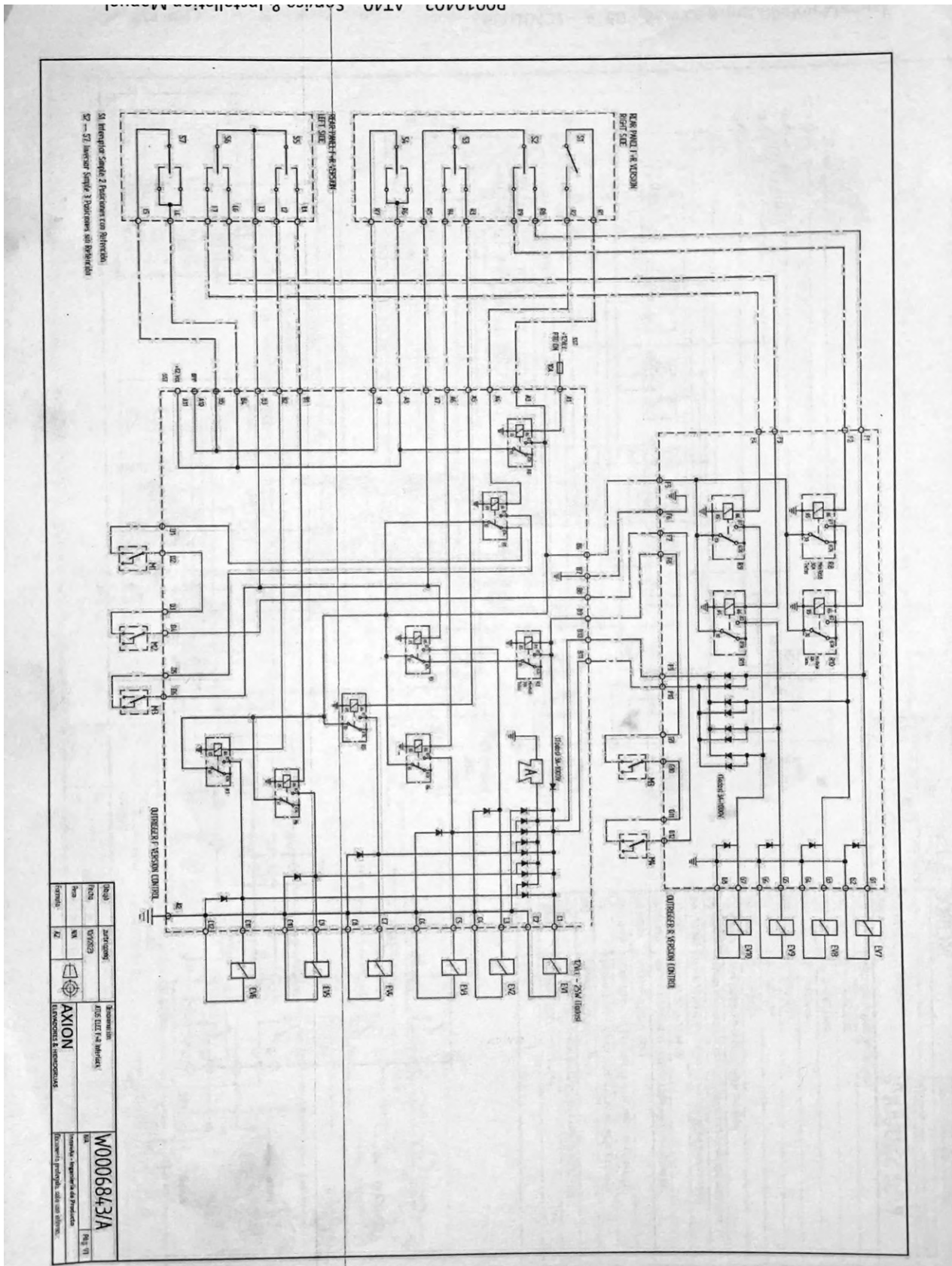

Part No.	Part Name	Manufacturer	Part No.
AXION	AXION	AXION	AXION
W0006843/A			

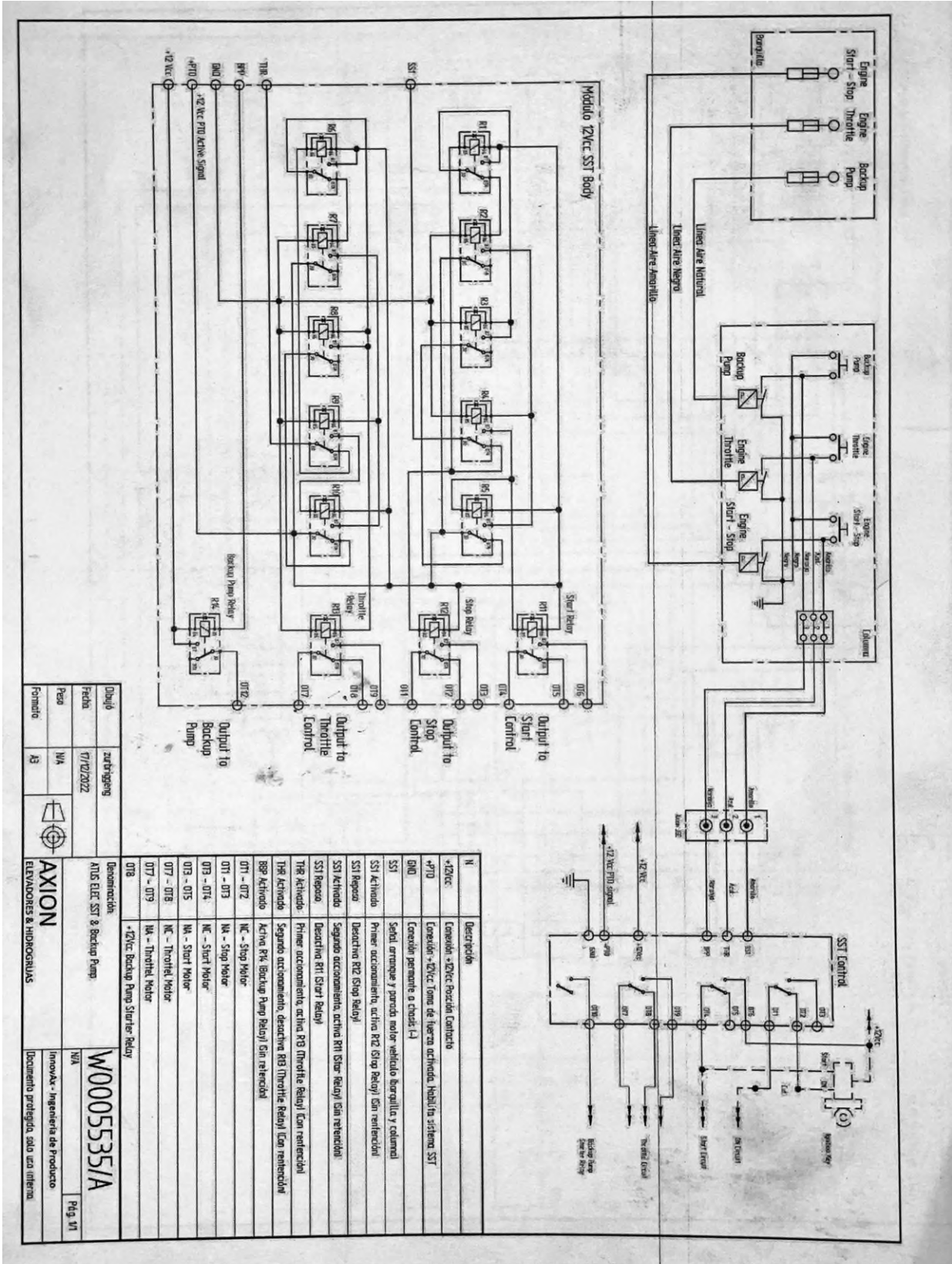

Dibujó	zathrigens
Fecha	17/02/2022
Pesa	WA
Formato	A3

N	Descripción
+12Vcc	Conexion +12Vcc Posición Contacto
+170	Conexion +12Vcc Toma de tierra activada. Manual sistema SST
GND	Conexion permanente a chasis (-)
SST	Señal arranque y parada motor vehículo burgalés y columnar
SST Activado	Primer accionamiento, activa R12 (Stop Relay) Sin reñecidón
SST Reposa	Desactiva R12 (Stop Relay)
SST Activado	Segundo accionamiento, activa R11 (Star Relay) Sin reñecidón
SST Reposa	Desactiva R11 (Star Relay) Sin reñecidón
T1R Activado	Primer accionamiento, activa R13 (Throttle Relay) Con reñecidón
T1R Reposa	Segundo accionamiento, desactiva R13 (Throttle Relay) Con reñecidón
B8P Activado	Activa R14 (Backup Pump Relay) Sin reñecidón
B8P Reposa	Desactiva R14 (Backup Pump Relay) Sin reñecidón
O11 - O12	NC - Stop Motor
O11 - O13	NA - Stop Motor
O13 - O14	NC - Start Motor
O13 - O15	NA - Start Motor
O17 - O18	NC - Throttle Motor
O17 - O19	NA - Throttle Motor
O18	+12Vcc Backup Pump Starter Relay

Diseñadora	W00055351A
ATS ELEC SST & Backup Pump	
Fecha	17/02/2022
Pesa	WA
Formato	A3

AXION
ELEVADORES & HIDROGRUAS

Innovate - Ingeniería de Producción
Documento protegido, cada una interna

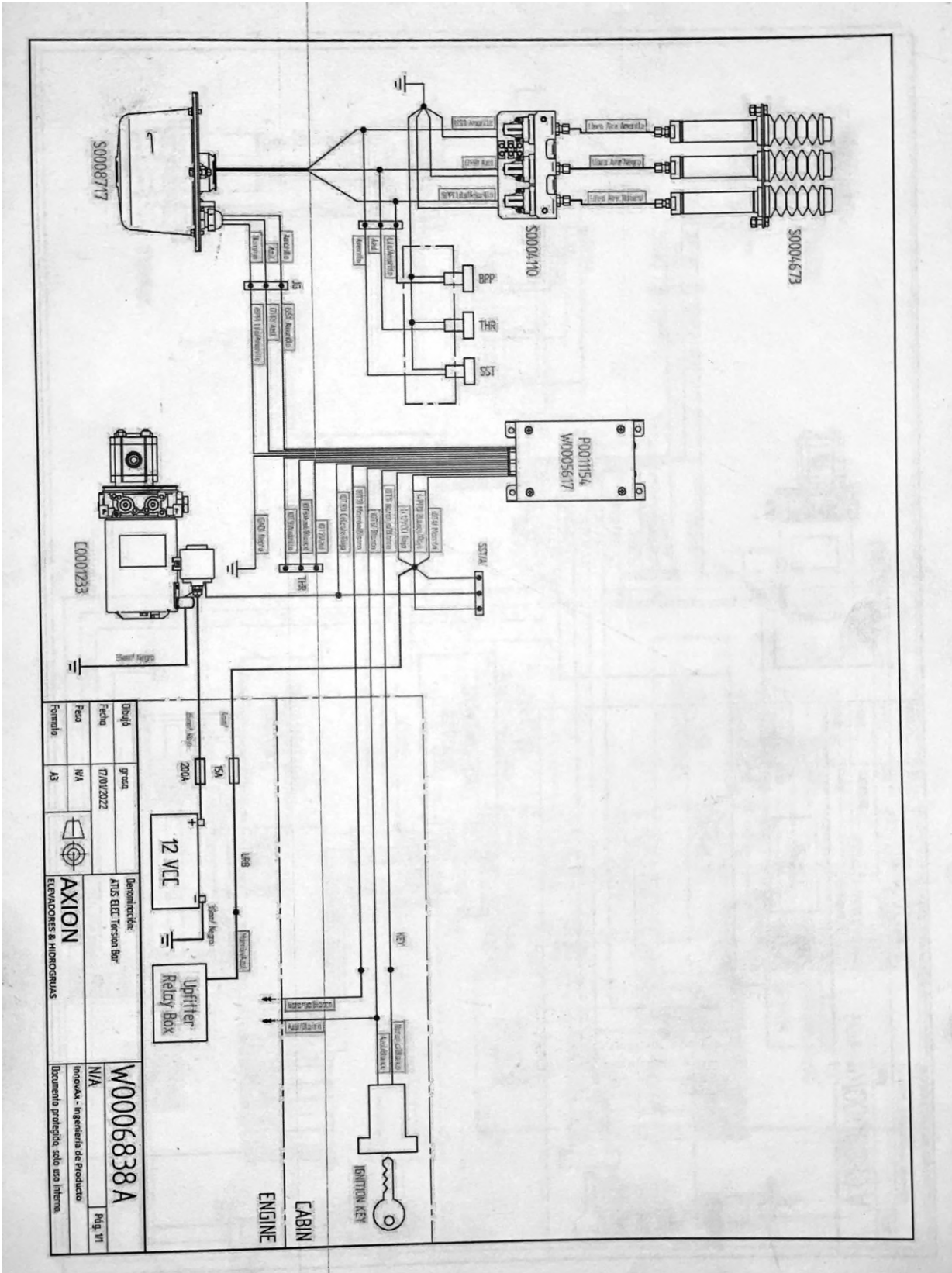

Disño	grosa	Desarrollador	ATIS ELEC Torcion Bar	W0006838A
Fecha	17/01/2022			N/A
País	NA			Pág. 1/1
Formato	A3			

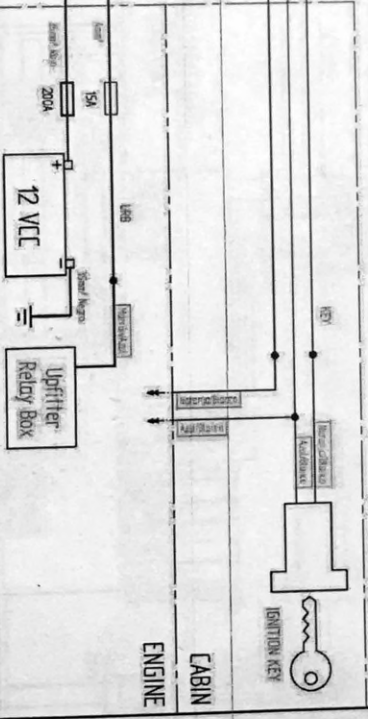

AXION
 ELEVALORES & HIDROGRUAS
 Documento protegido solo uso interno

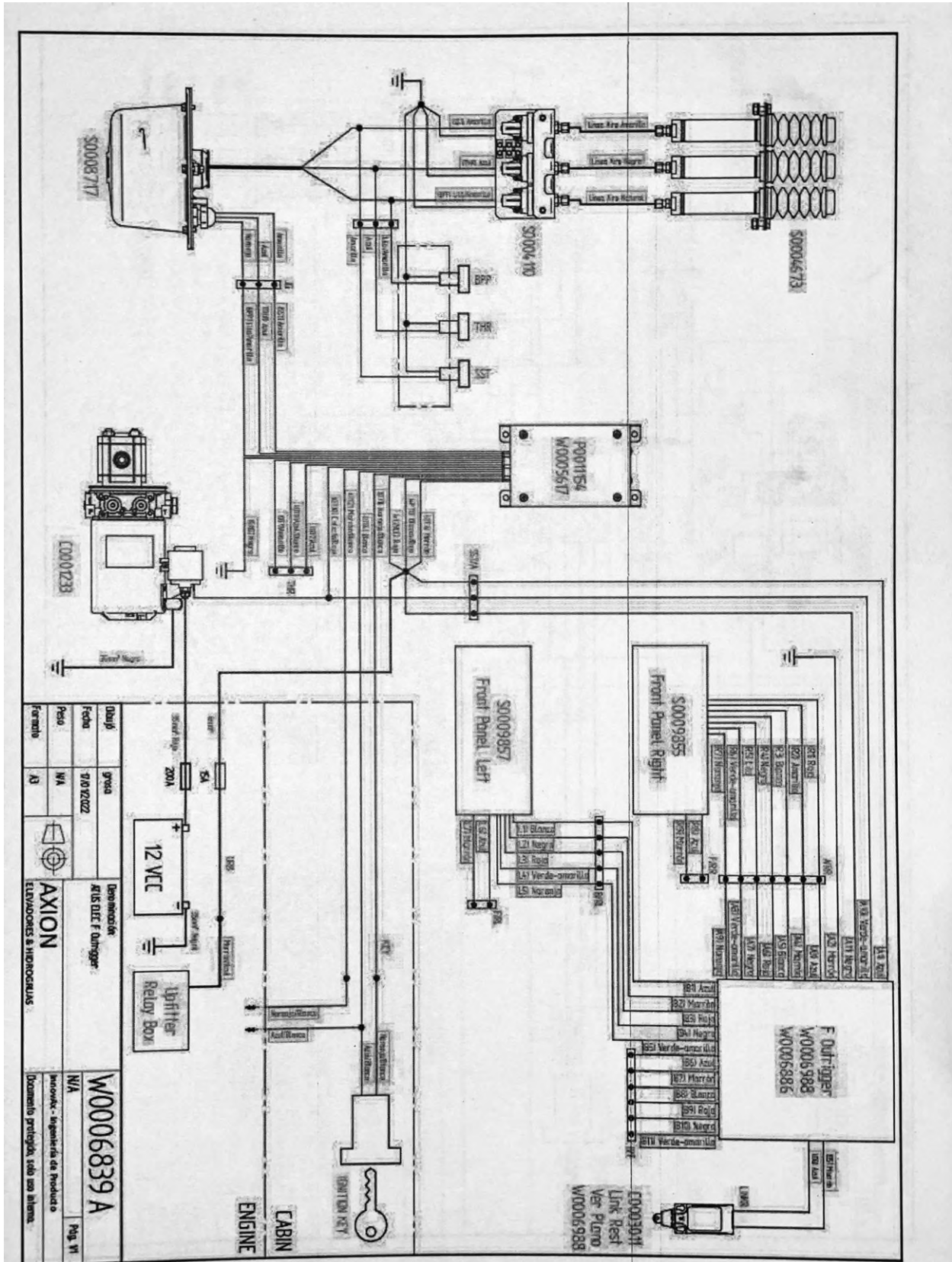

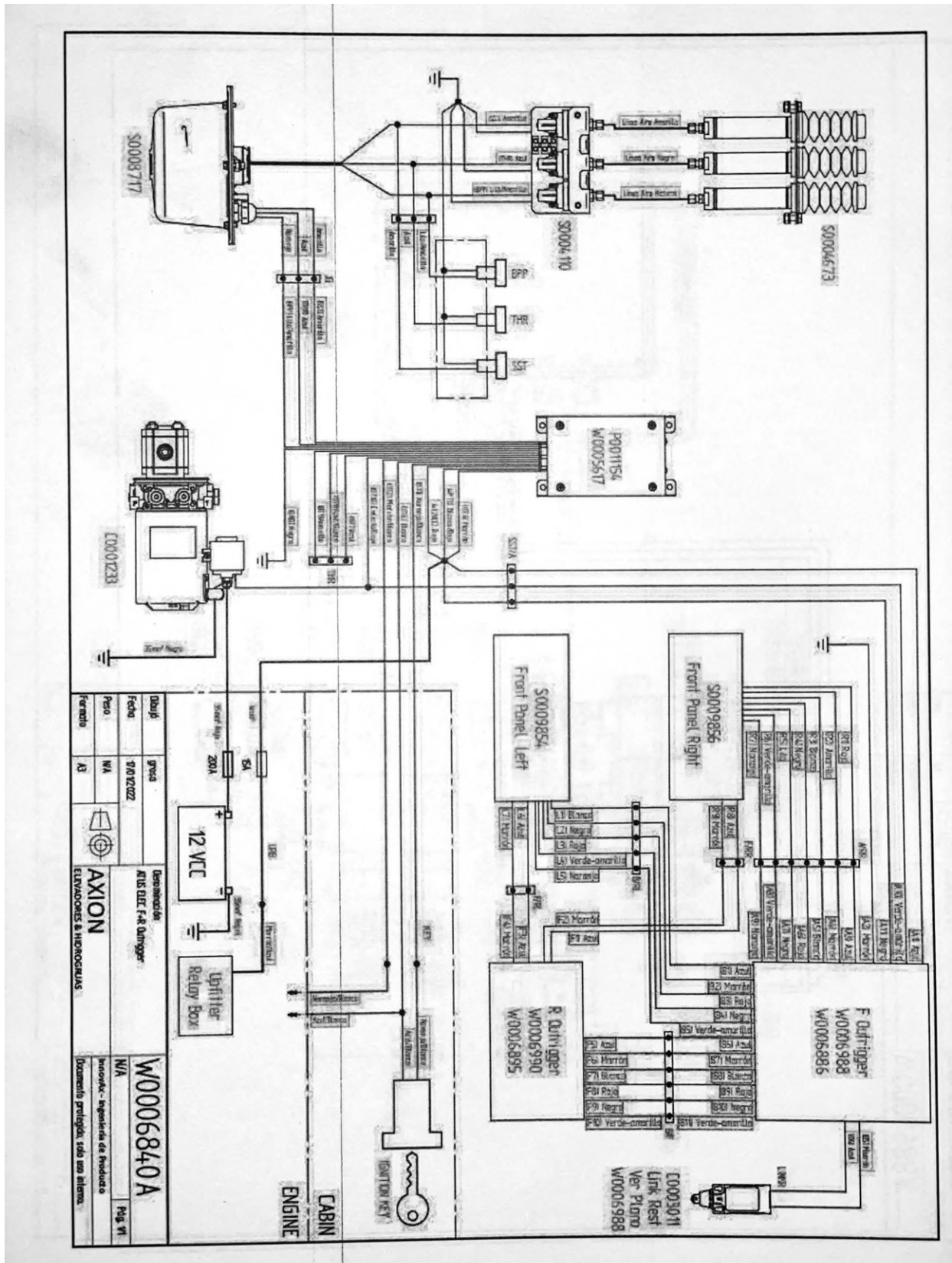

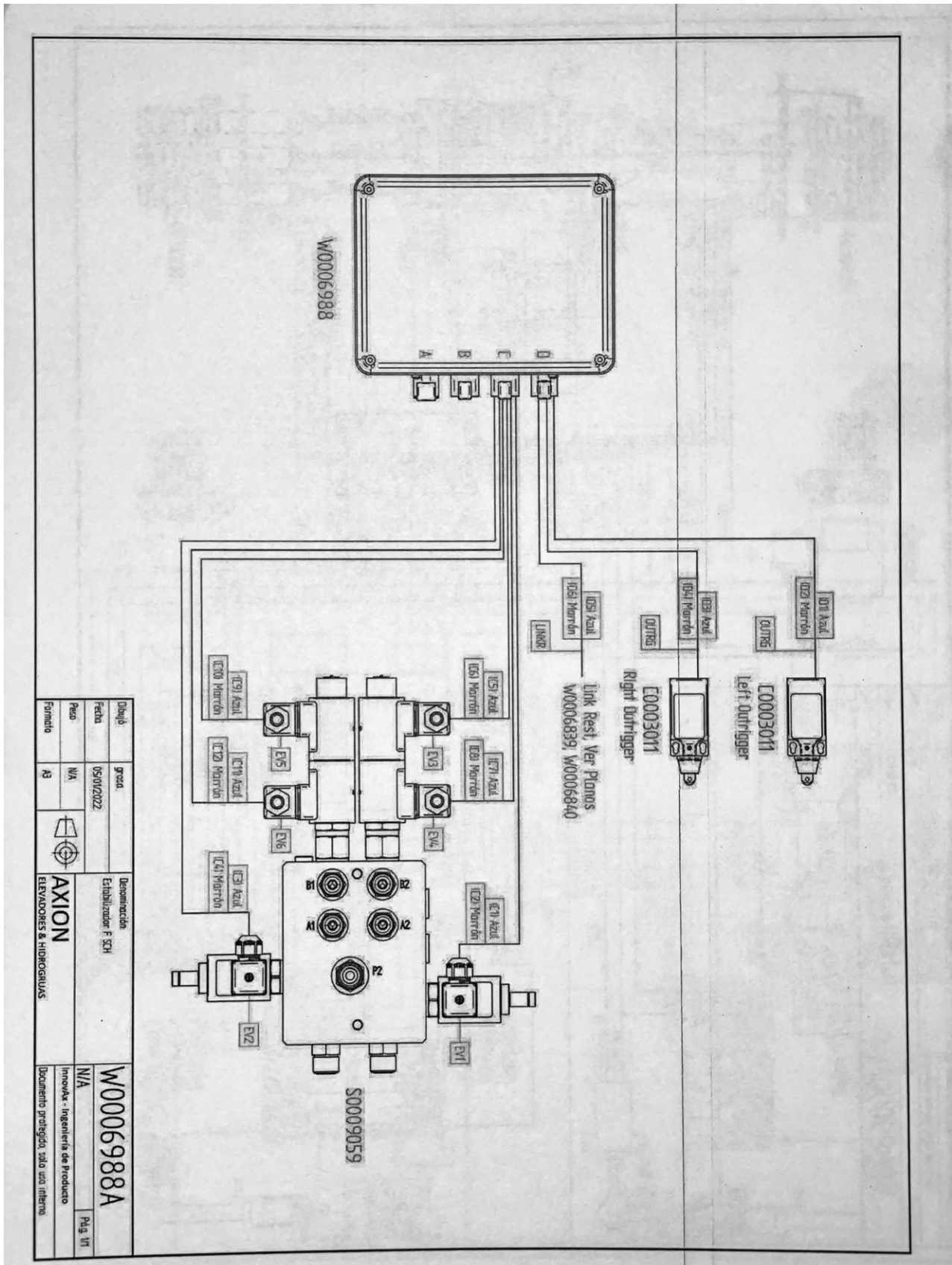

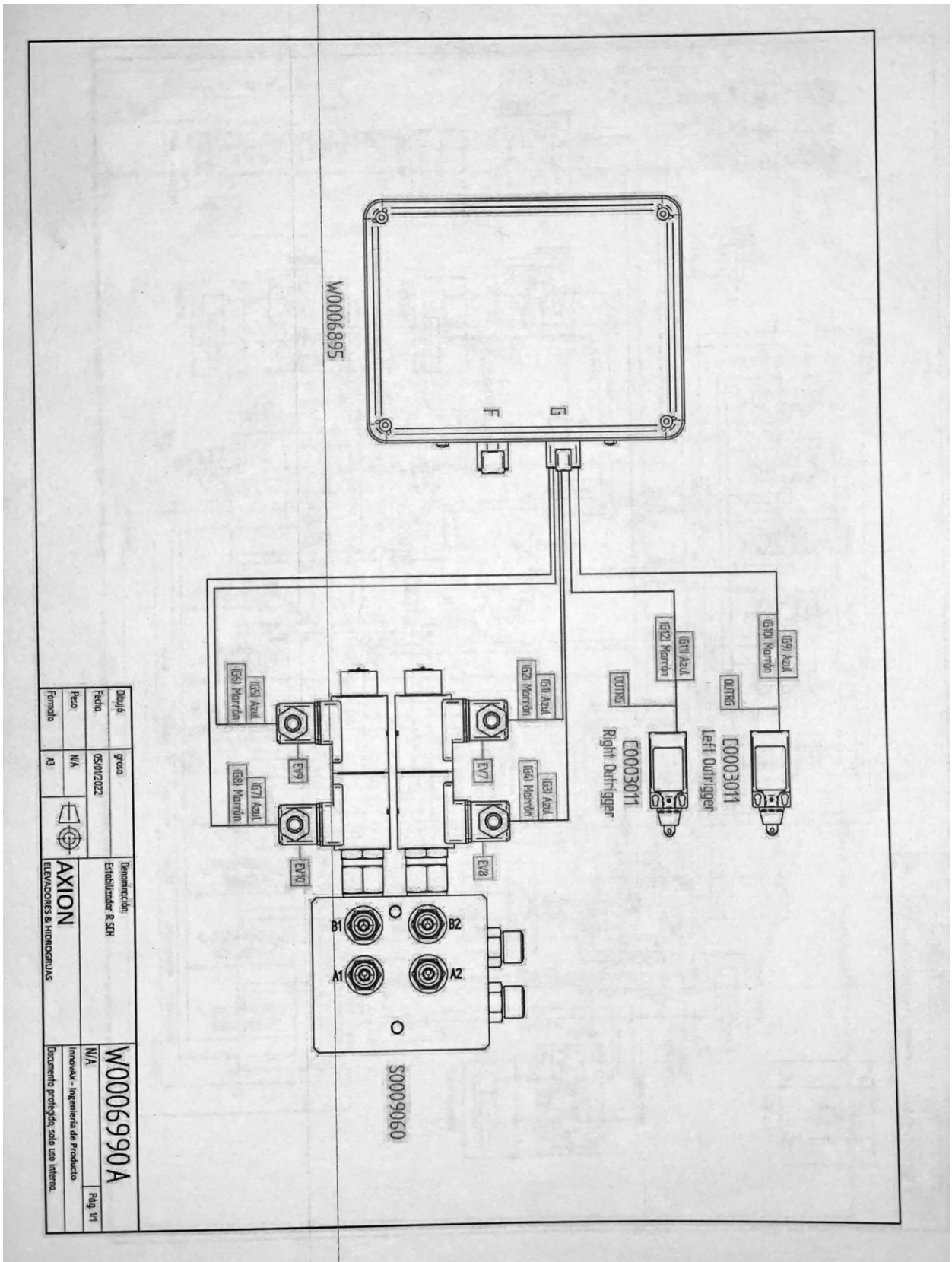

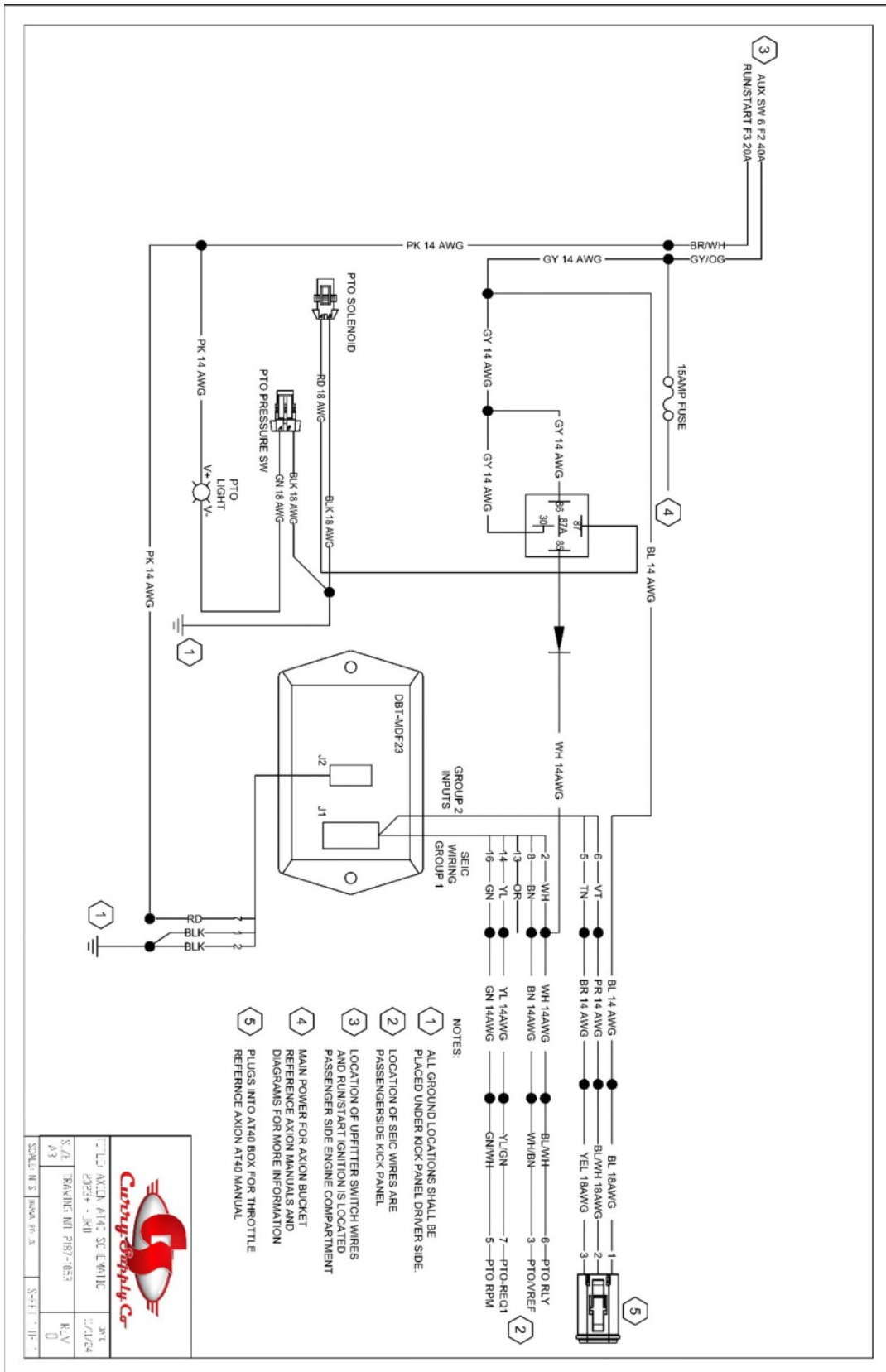

Curry Supply Co.

SCALE: NTS	INCHES TO FEET	SCALE: 1" = 16"
DATE: 03/21/24	REV: 0	
CURRY SUPPLY CO. 2023 + 2024 2923 + 2924 2923 + 2924		CURRY SUPPLY CO. 2923 + 2924 2923 + 2924



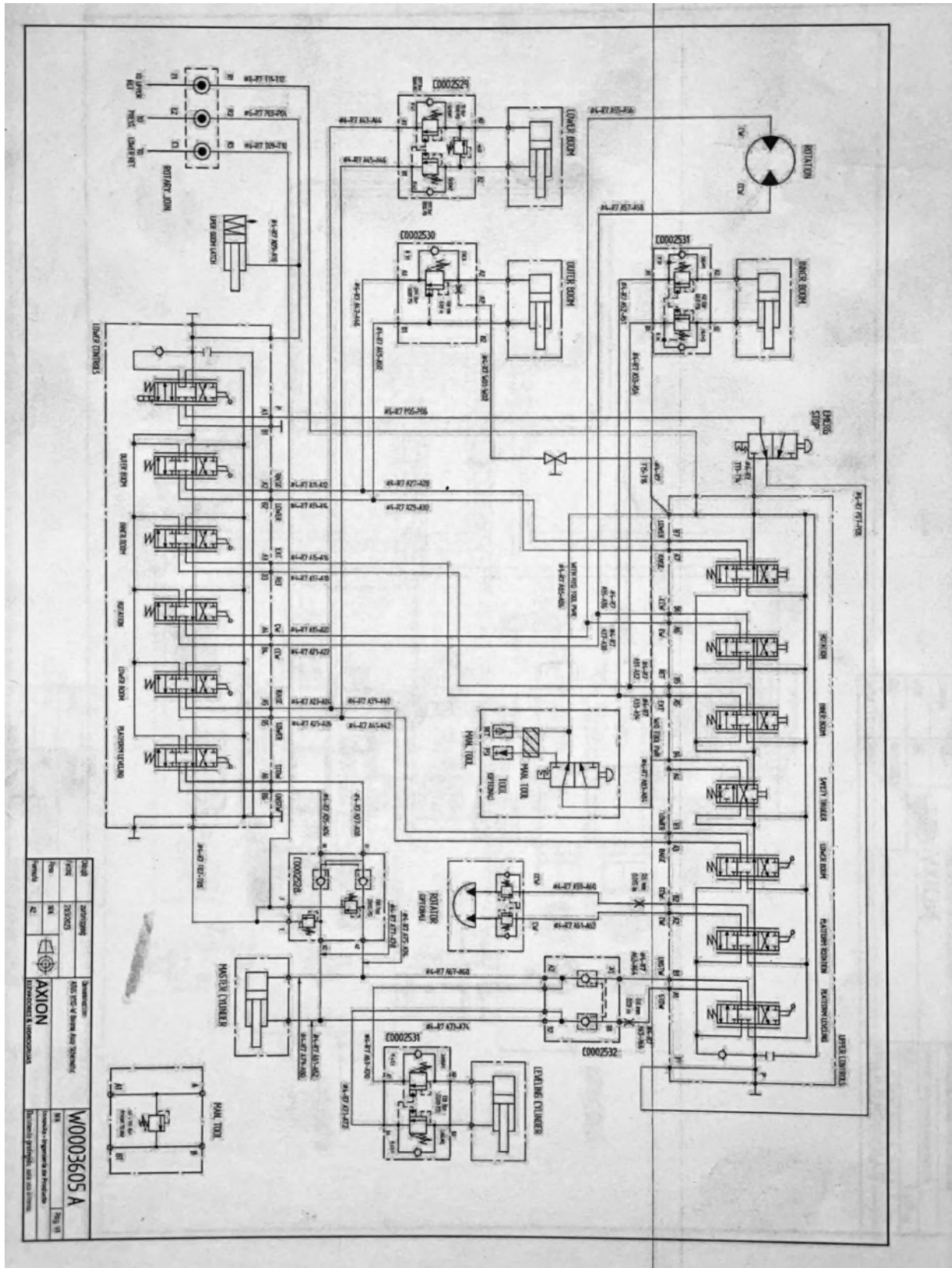

Part No.	W0003605 A
Rev.	1
Quantity	1
Material	Steel
Finish	Black
Notes	See Part of Draw for Details
Manufacturer	AXION EQUIPMENT & INSTRUMENTAL
Drawn By	W0003605 A
Checked By	
Approved By	
Date	10/11/11



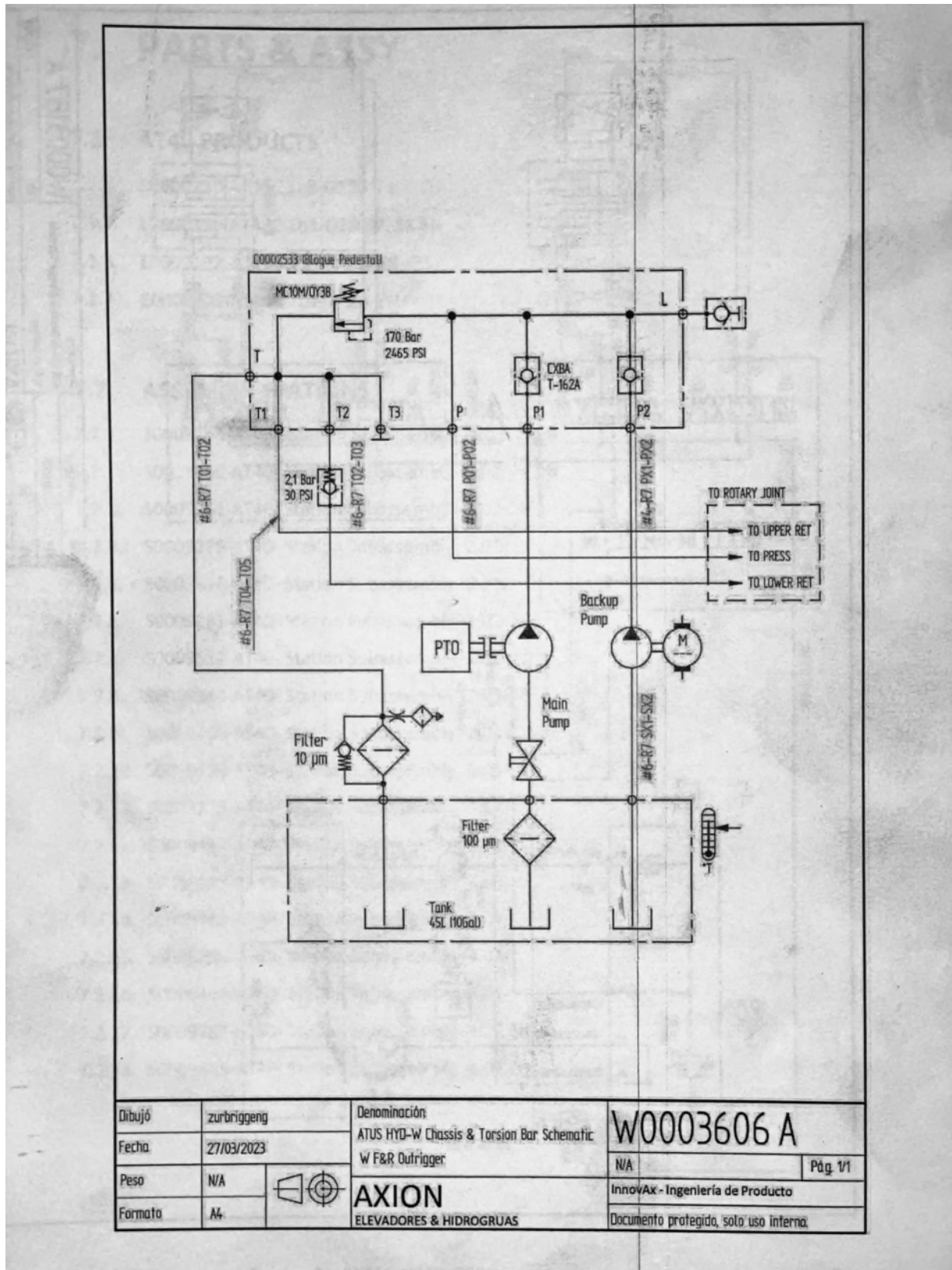

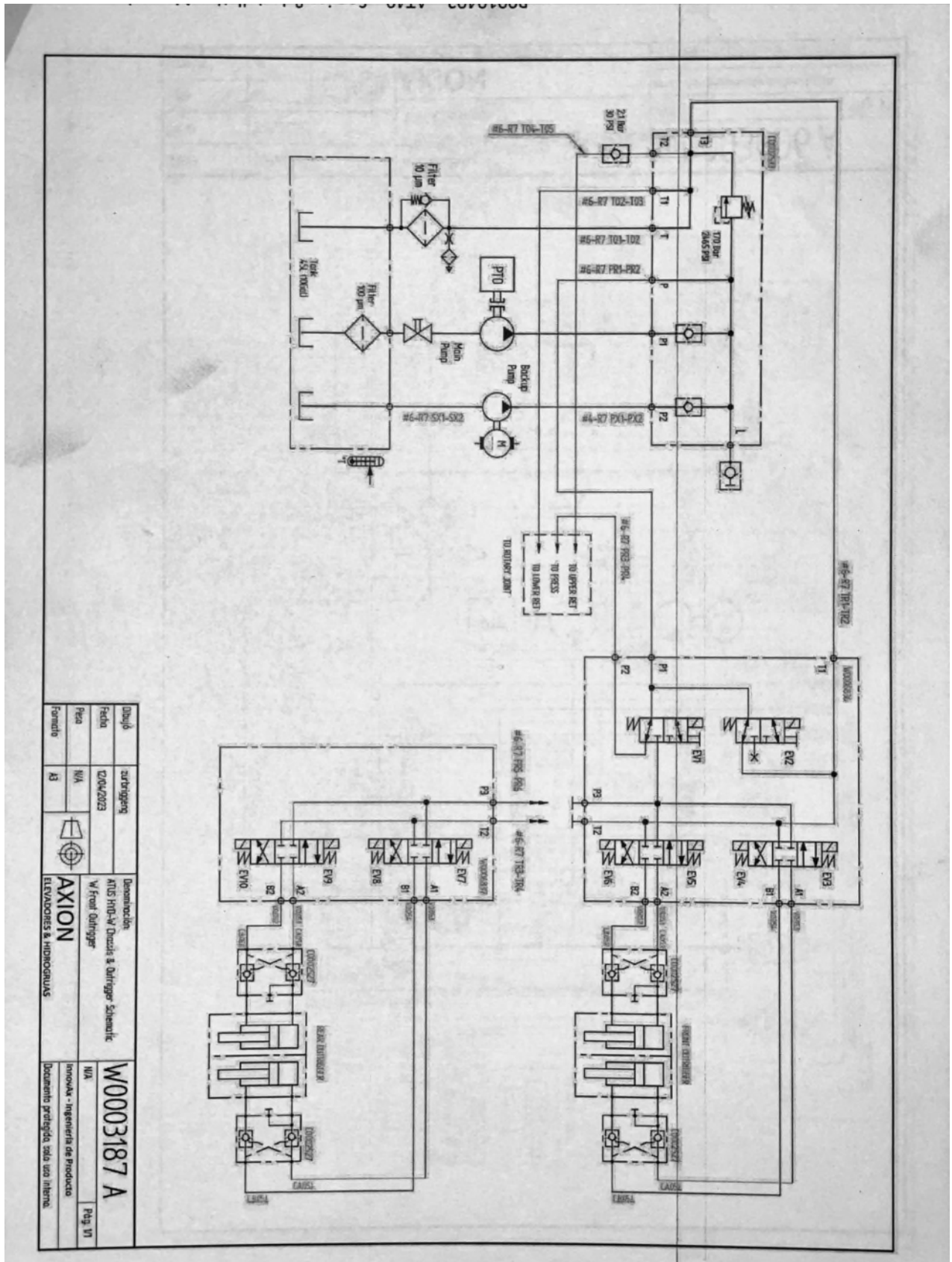

Objeto	revisión	Descripción	W0003187 A
Fecha	21/04/2023	Atlas HPC-A7 Doble & Dúplex Schematic	
Para	N/A	V. Final Dúplex	
Formato	A3	AXION	
		ELEVADORES & HIDROPAULS	
		Innovax - Ingeniería de Producto	
		Documento propiedad sólo uso interno	
			Pág. 1/1

SECTION 6

Troubleshooting

PROBLEM	POSSIBLE CAUSE	REMEDIES
No response from either upper or lower controls	The truck engine is not running.	Start the engine.
	PTO is not engaged.	Engage the PTO.
	Low hydraulic oil.	Add hydraulic oil.
	Relief valve is set too low.	Call Curry Supply Company for service 800.345.2829.
	Pinched pressure or return hydraulic line.	Repair or replace.
	Defective hydraulic pump.	Call Curry Supply Company for service 800.345.2829.
	Pressure compensated pump set too low.	Call Curry Supply Company for service 800.345.2829.
	Lift controls not selected.	Turn on the lift control switch.
No response from lower controls but upper controls are okay.	Platform override valve in wrong position.	Adjust platform override valve.
	Plugged or defective control valve.	Call Curry Supply Company for service 800.345.2829.
No response from upper controls but lower controls okay.	Platform override valve in wrong position.	Adjust platform override valve.
	Safety trigger not actuated or adjusted properly.	Actuate the safety trigger.
	Plugged or defective control valve.	Call Curry Supply Company for service 800.345.2829.
	Pinched pressure or return hydraulic line.	Repair or replace.
	The emergency stop valve is on.	Turn the emergency stop valve off.
Slow operations in all functions.	Valve spools are not fully open.	Call Curry Supply Company for service 800.345.2829.

	Oil is too heavy or cold.	Replace oil to correct viscosity for operating range temperature.
	Low hydraulic oil.	Add oil.
	System operating pressure or main system relief set too low.	Call Curry Supply Company for service 800.345.2829.
	Dirt or foreign matter in hydraulic system, filters valves, etc....	Call Curry Supply Company for service 800.345.2829.
	Pinched pressure or return hydraulic line.	Repair or replace.
	Engine speed is too low.	Increase engine speed.
	Excessive leakage in pump or control valve due to wear.	Call Curry Supply Company for service 800.345.2829.
	Safety trigger is not adjusted properly.	Call Curry Supply Company for service 800.345.2829.
Slow hydraulic cylinder operation but rotation is okay.	Holding valves are defective.	Call Curry Supply Company for service 800.345.2829.
	Main relief valve is set too low or open because of contamination.	Call Curry Supply Company for service 800.345.2829.
	Excessive pump leakage.	Call Curry Supply Company for service 800.345.2829.
	Internal cylinder leakage.	Call Curry Supply Company for service 800.345.2829.
	System operating pressure set too low.	Call Curry Supply Company for service 800.345.2829.
Slow operation of rotation system but boom motion is okay.	The rotation motor is defective.	Call Curry Supply Company for service 800.345.2829.
Excessive slack or erratic movement in the rotation system.	Gearbox mounting bolts are loose.	Tighten bolts. Refer to the manufacturer's service and maintenance manual for torque setting.
	Rotation bearing needs grease.	Call Curry Supply Company for service 800.345.2829.
	Excessive clearance between the pinion and the rotation bearing.	Call Curry Supply Company for service 800.345.2829.

	Rotation bearing or pinion teeth are damaged.	Call Curry Supply Company for service 800.345.2829.
	Gearbox worn or defective.	Call Curry Supply Company for service 800.345.2829.
	Rotation motor mounting bolts are loose.	Tighten bolts. Refer to the manufacturer's service and maintenance manual for torque setting.
Excessive vibration or noise.	Pressure relief valve is set too low.	Call Curry Supply Company for service 800.345.2829.
	Holding valve is defective.	Call Curry Supply Company for service 800.345.2829.
	Air in hydraulic system caused by a low oil supply or leak in the suction line.	Add oil &/or repair the leak.
	Pump cavitating.	Clean suction strainer.
Platform leveling is sloppy, out of level or erratic.	Holding valve is defective.	Call Curry Supply Company for service 800.345.2829.
	Leveling relief valve settings are too low.	Call Curry Supply Company for service 800.345.2829.
	Leveling check valves are leaking.	Repair or replace.
Boom drifts down when controls are in neutral.	Holding valve is defective.	Call Curry Supply Company for service 800.345.2829.
	Leakage past seals in the hydraulic cylinder.	Call Curry Supply Company for service 800.345.2829.
Remote engine start & stop doesn't work.	The engine start/stop system is not engaged.	Turn on the engine remote start system.
	The pressure switch is defective.	Call Curry Supply Company for service 800.345.2829.
	The airline is pinched or leaking.	Repair or replace.
	The electrical box is not grounded.	Ground the electrical box.
	The air cylinder is defective.	Call Curry Supply Company for service 800.345.2829.

	The theft deterrent disable switch is in the "OFF" position (if equipped).	Turn the theft deterrent switch on.
Truck cranks with the key switch but will not run.	The theft deterrent disable switch is in the "ON" position (if equipped).	Turn the theft deterrent switch off.
The truck engine runs erratically or stalls when controls are operated.	The idle speed is too slow.	Increase the engine speed.
	The engine is still cold.	Wait until the truck engine is warm.
	The engine needs a tune up.	Call Curry Supply Company for service 800.345.2829.
The hydraulic system is overheating.	The main system relief valve is set too low or is open because of contamination.	Call Curry Supply Company for service 800.345.2829.
	The hydraulic system operating pressure is too high.	Call Curry Supply Company for service 800.345.2829.
	Excessive hydraulic oil flow because of improper PTO ratio or the truck engine is operating at an excessive speed.	Reduce engine speed. If still overheating, refer to the manufacturer's service and maintenance manual.



For technical help or parts, please have the model number available and call our customer service 800.345.2829

SECTION 7

Warranty & Proprietary Information

Curry Supply Company warrants products designed and manufactured by Curry Supply Company to be free from defects in material and workmanship under proper use and maintenance. Products must be installed and operated in accordance with Curry Supply’s written instructions and capacities. All warranty periods will begin on the in-service date as defined in this document. This warranty shall cover the following Curry Supply Products:

	1 Year	2 Years	Variable
On Road Water / Flatbed / Crash Attenuator / Lube Skid			
Curry Manufactured Components		✓	
Paint Coverage on Curry Manufactured Parts	✓		
Parts	✓		
Repair Labor	✓		
Off Road / Dump / Industrial Carrier / Vacuum / Winch / Railroad			
Tank	✓		
Tank Exterior Paint Coverage	✓		
Parts	✓		
Repair Labor	✓		
Mechanics			
Body (Refer to Manufacture Warranty)			✓
Crane (Refer to Manufacture Warranty))			✓
Paint Coverage (Refer to Manufacture Warranty)			✓
Parts (Refer to Manufacture Warranty)			✓
Repair Labor (Refer to Manufacture Warranty)			✓
Lube			
Body (Refer to Manufacture Warranty)	✓		
Tanks (Refer to Manufacture Warranty)			✓
Parts	✓		
Repair Labor	✓		
Paint Coverage	✓		
Utility Lift			
Body (Refer to Manufacture Warranty)			✓
Lift (Axion)			✓
Parts	✓		
Repair Labor	✓		
Body Paint Coverage	✓		



Definitions

Curry Supply Manufactured Components/Structures – Includes any structural weldment or load bearing support structure manufactured by Curry Supply Company.

Rust Through on Curry Supply Components/Structures – Rust Through is defined as a hole in the metal caused by corrosion. Excluded is corrosion caused by external caustics, including but not limited to improper cleaning material, road salt and other chemicals left on the structure for extended periods of time.

Paint Coverage on Curry Supply Manufactured Parts – Curry Supply guarantees that exterior paint will not fail in terms of adhesion, blistering or unreasonable loss of color or gloss for a 1-year period. Excluded is damage such as chips, dents, scratches, tank interior coating, and corrosion due to caustic chemicals (e.g. Brine Solution / Leachate) and dirt build-up. Regular cleaning and maintenance of the product to remove external factors is expected to keep this warranty in force.

Vendor Supplied Components/Structures – Products purchased by Curry Supply from outside vendors. These items shall be covered by the warranty offered by the respective manufacturer only. Curry Supply does not obligate itself to any such warranty.

Warranty Process

Curry Supply's obligation under this warranty is limited to, and the sole remedy for any such defect shall be the repair and/or replacement (at Curry Supply's option) of the unaltered part and/or component in question. Curry Supply after-sales service personnel must be notified by telephone, email, or letter of any warranty applicable damage within fourteen (14) days of its occurrence. If possible, Curry Supply will ship the replacement part within 24 hours of notification by the most economical, yet expedient, means possible. Expedited freight delivery will be at the expense of the owner.

Warranty claims must be submitted and shall be processed in accordance with Curry Supply's established warranty claim procedure. Curry Supply after-sales service personnel must be contacted prior to any warranty claim. A return materials authorization (RMA) may be issued to the claiming party prior to the return of warranty parts. Parts returned without prior authorization will not be recognized for warranty consideration. All damaged parts must be returned to Curry Supply freight prepaid; freight collect returns will be refused. Freight reimbursement of returned parts will be considered as part of the warranty claim.

Warranty Repair

Warranty service will be performed by any Curry Supply factory, Curry Supply mobile technician, Curry Supply authorized service partner, or by the affected owner. At the time of requesting warranty service, Curry Supply after-sales service personnel will verify date of delivery of the product. The owner shall be obligated to pay for any overtime labor requested of the servicing company by the owner, any field service call charges, and any towing and/or transportation charges associated with moving the equipment to the designated repair/service provider.

All obligations of Curry Supply and its service providers shall be voided if someone other than an authorized Curry Supply provider performs other than routine maintenance service without prior written or verbal approval from Curry Supply. In the case repair work is performed on a Curry Supply-manufactured product, original Curry Supply parts must be used to keep the warranty in force. The warranty may also be voided if the product is modified or altered in any way not approved, in writing, by Curry Supply.

Warranty Limitations/Responsibilities

This warranty covers only defective material and workmanship. It does not cover depreciation or damage caused by normal wear and tear, accident, mishap, untrained operators, or improper or unintended use. The owner has the obligation of performing routine care and maintenance duties as stated in Curry Supply's written instructions, recommendations, and specifications. Any damage resulting from owner/operator failure to perform such duties shall void the coverage of this warranty. The owner will pay the cost of labor and supplies associated with routine maintenance.

The only remedies the owner has in connection with the breach or performance of any warranty on the Curry Supply product specified are those set above. In no event will Curry Supply, or any company affiliated with Curry Supply, be liable for business interruptions, costs of delay, or for any special, indirect, incidental, or consequential costs or damages. Such costs may include, but are not limited to, loss of time, loss of revenue, loss of use, wages, salaries, commissions, lodging, meals, towing, hydraulic fluid, or any other incidental cost.

All products purchased by Curry Supply from outside vendors shall be covered by the warranty offered by that respective manufacturer only. Curry Supply does not participate in, or obligate itself to, any such warranty.

Curry Supply reserves the right to make changes in design or improvement upon its products without imposing upon itself the same upon its products theretofore manufactured.

This warranty will apply to all Curry Supply manufactured components/structures and upfit workmanship shipped from Curry Supply's factory. The warranty is for the use of the original owner only and is not transferable without prior written permission from Curry Supply.

Curry Supply After-Sales Contact Information:

Phone: (800) 345-2829

Email: service@currysupply.com

Mailing Address: 1477 DeGol Industrial Drive, Hollidaysburg, PA 16648

THIS WARRANTY IS EXPRESSLY IN LIEU OF ANY OTHER WARRANTIES, EXPRESS OR IMPLIED, INCLUDING ANY WARRANTY OF MERCHANTABILITY OR FITNESS FOR A PARTICULAR PURPOSE. REMEDIES UNDER THIS WARRANTY ARE LIMITED TO THE PROVISION OF MATERIAL AND SERVICES, AS SPECIFIED HEREIN. CURRY SUPPLY COMPANY IS NOT RESPONSIBLE FOR INCIDENTAL OR CONSEQUENTIAL DAMAGES.

EXCEPT AS STATED, THERE IS NO WARRANTY, EXPRESS OR IMPLIED, IN CONNECTION WITH THE DESIGN, MANUFACTURE, SALE OR USE OF THE MACHINERY, ACCESSORIES, EQUIPMENT AND PARTS SOLD BY CURRY SUPPLY CO. CURRY SUPPLY COMPANY'S LIABILITY ON ITS WARRANTY SHALL IN NO EVENT EXCEED THE COST OF THE ITEM OF SALE.