



OPERATORS MANUAL

ON-ROAD WATER TRUCKS



2,000 gallon

4,000 gallon

Curry Supply Co., 1477 Degol Industrial Drive, Hollidaysburg, PA 16648

Curry Supply Co.

800-3



ON-ROAD WATER TRUCKS

SPECIFICATIONS

- 2,000 – 6,000 US gallon tanks
- ASTM A36 steel construction for durability
- FEA tested and designed
- Internal baffles
- Full length shaped tank runners
- LINE-X® lined fender trays
- 24" manway with mesh lift out grate
- Water level indicator
- (2) Front flushing, (1) side, (2) rear, independently controlled spray heads with air operated valves
- 4" x 3" water pump
- Manual rewind hose reel with 50' of 1-1/2" hose, adjustable nozzle
- 2-1/2" hydrant fill with anti-siphon air gap
- Heavy duty rear bumper
- DOT compliant wiring and lighting system
- Spring-loaded mounting system for long life
- Interior tank coating for superior protection
- Powder-coated parts

OPTIONAL EQUIPMENT

- Electric rewind hose reel
- Other water pumps available
- Diesel driven water pump
- Water cannon, remote controlled
- Rear gravity bar, air controlled on/off valve
- 10" rear quick dump
- Storage boxes
- Work light packages
- Strobe light packages
- Primer self loading system (creek/pond fill)
- Stainless steel tanks
- Ship out kits available for self-assembly

YOUR JOBS. OUR TRUCKS.

TABLE OF CONTENTS

Sections

Introduction & Safety Messages.....	4
System Descriptions	8
Normal Operations.....	14
Maintenance & Lubrication.....	24
Schematics	31
Troubleshooting	44
Warranty & Proprietary Information.....	45

SECTION 1

Introduction & Safety Messages

CONTACT US

Curry Supply Company

1477 Degol Industrial Drive, Hollidaysburg, PA 16648

service@currysupply.com CurrySupply.com

Parts 800.567.5127

Warranty Service 800.345.2829

MANUAL USAGE

This Technical Manual contains information to safely operate more than (1) configuration of "Curry Supply On-Road Water Truck". The parts shown may not reflect the exact configuration on your truck. "Custom" style trucks may have parts not listed. If a system is not covered in this manual, please contact Curry Supply Co.

support at 800.345.2829 or

service@currysupply.com.

All personnel working on or operating the machine must become familiar with the following safety messages.

Due to the nature of these processes, ensure that all safety information, warnings, and instructions are read and understood by the operator before any operation or maintenance procedures are performed.

This manual does not supersede any local, state, or federal laws.

WARNING, CAUTION, AND NOTES

The following definitions found throughout this manual and apply as follows:

WARNING

OPERATING PROCEDURES AND TECHNIQUES COULD RESULT IN PERSONAL INJURY OR LOSS OF LIFE IF NOT FOLLOWED CORRECTLY.

CAUTION

OPERATING PROCEDURES AND TECHNIQUES WHICH COULD RESULT IN DAMAGE TO EQUIPMENT IF NOT FOLLOWED CORRECTLY.

NOTE

OPERATING PROCEDURES AND TECHNIQUES THAT ARE CONSIDERED ESSENTIAL TO EMPHASIZE.

SAFETY MESSAGES

There are a variety of specific safety messages on this machine. All personnel working on or operating the machine must become familiar with all the safety messages.

Make sure that the safety messages are completely legible. Clean the safety messages or replace the safety messages if you cannot read the words. Replace the illustrations if the illustrations are not clear and visible. When you clean the safety messages, use soap and water, NOT solvent, gasoline, or other harsh chemicals.

Replace any safety message that is damaged or missing. If a safety message was attached to a part that was replaced, install a new message on the replacement part.

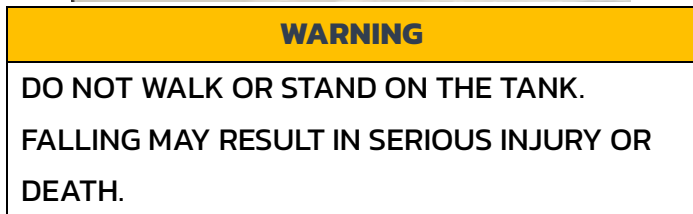
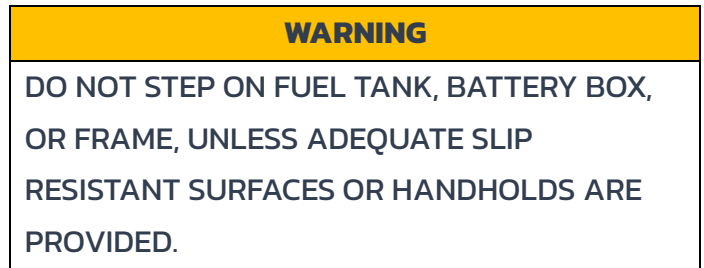
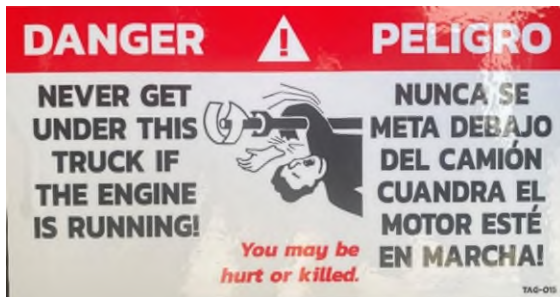
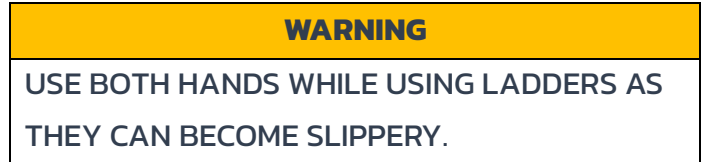
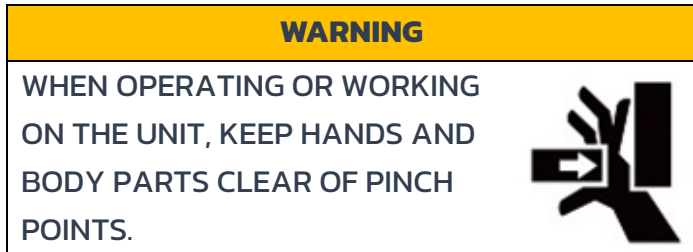

WARNING

DO NOT DISCONNECT HOSES FROM AIR SPRINGS OR HEIGHT CONTROL VALVE.



Do not disconnect hoses from air springs or height control valve. Hand may be crushed.
22-01205 REV C

WARNING

CLOSING SPRAY HEADS WHILE UNDER PRESSURE WILL CAUSE DAMAGE TO THE WATER PUMP

CAUTION

DO NOT CLOSE SPRAYHEADS UNDER PRESSURE PUMP DAMAGE WILL OCCUR

TAG-003

WARNING

IMPROPER USE OF EQUIPMENT COULD CAUSE SERIOUS INJURY OR DEATH. PLEASE READ AND UNDERSTAND ALL INSTRUCTIONS.



WARNING

WHEN OPERATING OR WORKING ON THE UNIT, KEEP HANDS AND BODY PARTS CLEAR OF PINCH POINTS.



WARNING

IMPROPER DISPLAY COULD CAUSE A TRAFFIC ACCIDENT RESULTING IN SEVERE INJURY OR DEATH.



WARNING

CONTACT WITH LIVE ELECTRICAL CIRCUITS COULD DAMAGE EQUIPMENT OR CAUSE INJURY.



WARNING

MOVING PARTS CAN CRUSH AND CUT. KEEP HANDS, FEET, HAIR, AND LOOSE CLOTHING AWAY FROM MOVING PARTS.



CAUTION

ADVERSE WEATHER CONDITIONS CAN CAUSE EQUIPMENT DAMAGE. WHENEVER POSSIBLE, PERFORM MAINTENANCE INDOORS.



WARNING

ALWAYS WEAR THE PROPER PPE WHILE OPERATING THE UNIT.



WARNING

ALWAYS WEAR YOUR SAFETY BELT WHILE DRIVING THE VEHICLE. IF VEHICLE TIPS, STAY BUCKLED AND INSIDE OF CAB AREA.



WARNING

DO NOT OPERATE THE UNIT WHILE INTOXICATED OR EXTREMELY EXHAUSTED.



WARNING

DO NOT WALK ON TOP OF THE VEHICLE. FALLING FROM VEHICLE CAN RESULT IN SERIOUS INJURY.



CAUTION

DRAIN ALL WATER DAILY DURING FREEZING TEMPERATURES. FREEZING WATER CAN RESULT IN DAMAGE TO EQUIPMENT.



WARNING

HIGH PRESSURE WATER. DO NOT OPERATE THE SPRAY VALVES OR CANNON UNTIL ALL THE PERSONNEL ARE AT A SAFE DISTANCE AWAY FROM THE VEHICLE.



WARNING

THE VEHICLE IS EQUIPPED WITH A BACK-UP ALARM. ALARM MUST SOUND WHEN OPERATING THIS VEHICLE IN REVERSE.



SECTION 2

System Descriptions

SIDE VIEW OF TRUCK



REAR VIEW OF TRUCK



WATER TANK



Located on top of the chassis, the tank is the holding area for water. Curry On-Road water tanks range from 2,000-6,000 US gallons.

SPRAY BARS



Mounted to the front and rear of the vehicle. The Spray bars are equipped with (2) spray heads each.

SPRAY HEADS



Located on spray bars in the front, side, and rear of the truck. This is where water will spray out when the valve is opened. The valves are controlled by a control panel inside the truck cab.

WATER PUMP

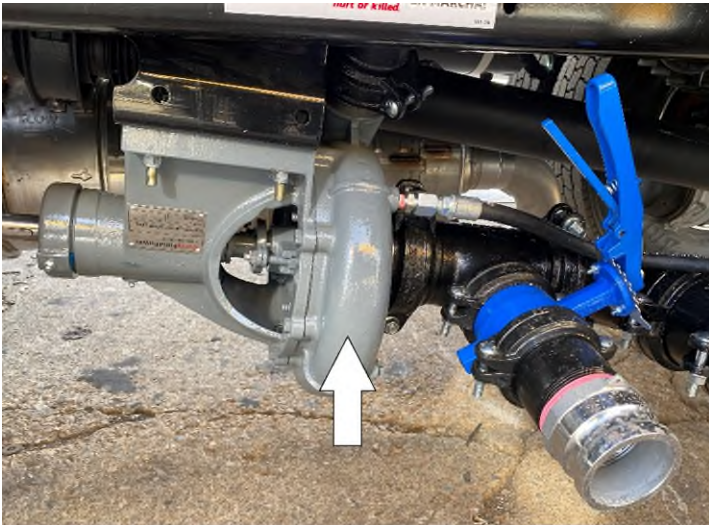

The water pump is located under the tank, attached to the chassis. Powered by the PTO, the water pump pressurizes the system to dispense water out of the spray heads.

FILL TUBE



Located on the rear of the truck, the fill tube is the main source to fill the tank with water. Water travels up this tube to an opening on the top of the tank, filling it with water.

SUCTION / CREEK FILL VALVES

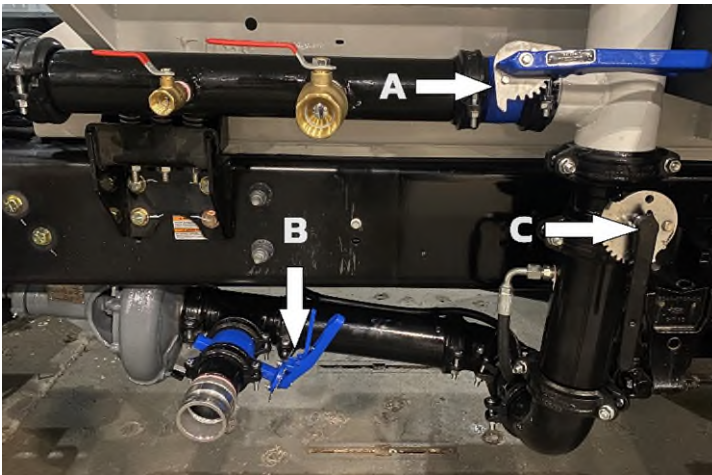

Located on the lower driver side of the truck, these valves are used in the "Suction or Creek Fill" method to suction water into the tank.

- A – Creek Tank Fill Valve
- B – Creek Suction Valve
- C – Creek Sump Valve

WATER TANK FILL OPENING



Located on top of the tank, this is where the tank is filled by water, either by a water dump or fill tube.

SIGHT TUBE INDICATOR



Located on both the front and rear of the tank, is a clear tube that displays the level of water inside of the tank. The tank should be at minimum 1/4 full to operate water functions.

GALLON INDICATOR DRAIN VALVE

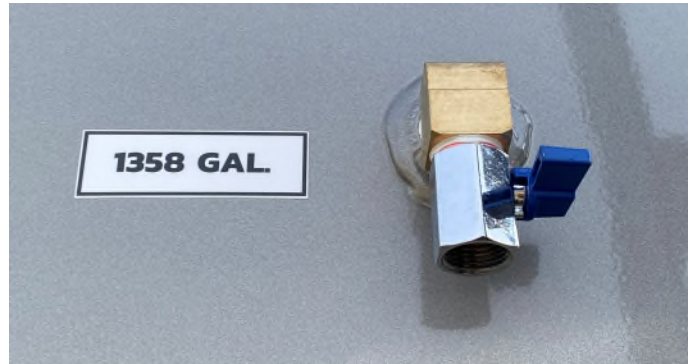

Located on the rear end of the tank, these drain water from the tank to the marked gallon level.

BACK UP CAMERA



Located on the rear of the tank, when in reverse, the backup camera will show the view behind the vehicle on the dashboard display.

HOSE & HOSE REEL



Typically located on the lower rear of the vehicle, fitted with a 50-foot 1 1/2-inch rubber hose with a twist style nozzle. Both electric and manual reels are available.

STATIONARY THROTTLE

(Ford & Mack models Only)



(If installed) Located on the rear of the vehicle, the stationary throttle allows the operator to turn the PTO on and off and raise the RPMs to the correct level from outside of the vehicle.

WATER DRAIN VALVES



There are (4) water drains installed. They are located on the tank, spray bars, and water pump. These are used to drain the water after use.

COMPRESSOR

(Hydraulic brake trucks only)



Located on the passenger side of the truck, behind the cab, the compressor is only equipped on vehicles with hydraulic brakes. It pressurizes the spray system.

WATER CANNON (if installed)



Located on top of the truck, between the water tank and cab, it gives the ability to spray water in precise locations by rotating both horizontally and vertically. It is controlled by a joystick inside of the cab.

INTERIOR CONTROLS

PTO (POWER TAKE OFF) CONTROLS

Located on the dash, the PTO transfers power from the engine to the water pump. The PTO can be run in "Stationary" or "Mobile" mode.

Stationary mode is used when the vehicle is not in motion, and Mobile mode is used when the vehicle is in motion. There are different variants of PTO controls.

NOTE

FOLLOW CHASSIS SPECIFIC INSTRUCTIONS TO ENGAGE THE PTO.

CAUTION

CHECK THE PTO FOR LEAKS AND LOOSE MOUNTING HARDWARE (STUDS, CAP SCREWS, NUTS). CHECK WITHIN THE FIRST WEEK OF USE, MONTHLY THEREAFTER, OR EVERY 100 HOURS OF OPERATION WHICHEVER COMES FIRST.

TAG-047



International dashboard PTO Controls



Ford model with red covering (left) Pressing in the top part of the button turns on "Stationary Mode". Lifting the red cover and pressing the bottom part of the button activates "Mobile Mode."

SPRAY HEAD CONTROLS

Control tower



Dashboard Control



Located inside the cab, these controls open and close the spray heads. There are two different control panels that come standard with Curry Supply water trucks. One option is a control tower that has slide levers to open and close the spray heads. The spray head location will be labeled along with on/off or open/close.

Another option is a dashboard system that uses push buttons. Push in the top part of button to open a spray head, and a light will come on to show that it is open. Push the bottom part of the button to close it and the light will turn off.

WATER CANNON CONTROL SWITCH

(If installed)



The water cannon valve operates the same way as the spray head controls. Direction of the water cannon is controlled by the joystick located inside the cab.

WATER CANNON JOYSTICK

(If installed)



Located inside the cab, the water cannon joystick allows the operator to aim the cannon in different directions and control the spray width. The cannon can rotate both horizontally and vertically.

SECTION 3

Normal Operations

This section provides the vehicle operator with step-by-step operating procedures for the installed systems. A quick reference operations card will be supplied and placed into the cab.

Prior to any operation, please perform a walk around inspection of the vehicle. Check specifically for any leaks or broken hoses.

VALVE OPERATION

Valves can be opened or closed by hand to allow or restrict flow.



OPEN – Handle aligns with the tube or hose.

CLOSED – Handle is perpendicular, or at 90 degrees, with the tube or hose.

FILL OPERATIONS

The tank may be filled using two methods, hydrant fill and suction/creek fill.

14

CAUTION

FILL TANK WITH FRESH NON-POTABLE WATER ONLY. SALTWATER AND OTHER CHEMICALS COULD RUIN THE INTERIOR COATING

HYDRANT TANK FILL

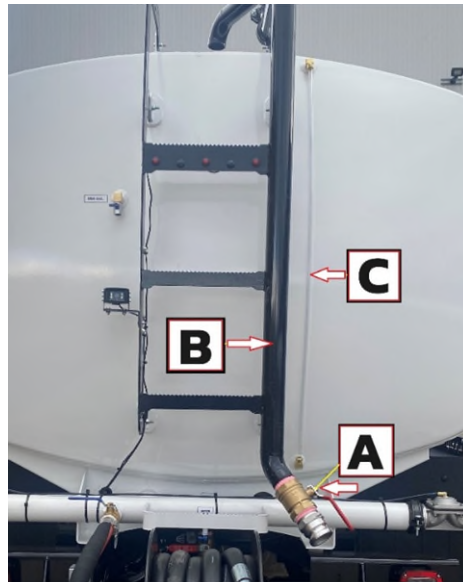

A – Fill Tube Valve

B – Fill Tube

C – Sight Tube Indicator

1. Ensure that the truck is parked, and the emergency brake is ON. If truck has air brakes, place truck in neutral and have air brakes engaged.
2. Ensure tank fill opening is clear of obstruction.
3. Ensure the fill tube valve is clear of obstruction.

4. Attach hydrant hose to fill tube valve on rear of truck. "A"
5. OPEN Valve on fill tube.
6. Attach the other end of hose to fire hydrant or water source valve.
7. OPEN water source to allow flow of water through fill tube. "B"
8. Once filled to the desired level, CLOSE the water source to stop the flow of water.
The water level can be viewed by fill tube indicator "C."
9. CLOSE fill tube valve.
10. Remove hydrant hose from water source.
11. Remove hydrant hose from fill tube valve.

3. Submerge the end of hose with strainer in water.

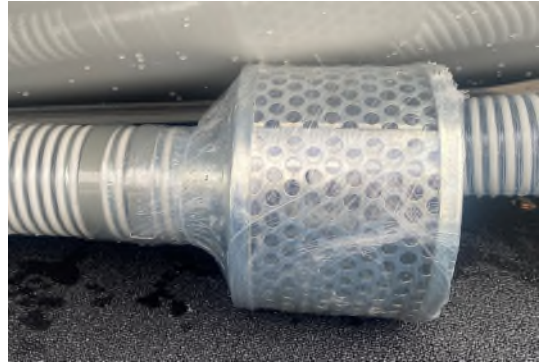

4. OPEN the Sump Valve (C) and Tank Fill (A) Valve.
5. Turn the truck ignition ON
6. Ensure the emergency brake is ON
7. Activate the PTO in Stationary Mode

SUCTION FILL/CREEK FILL OPERATION

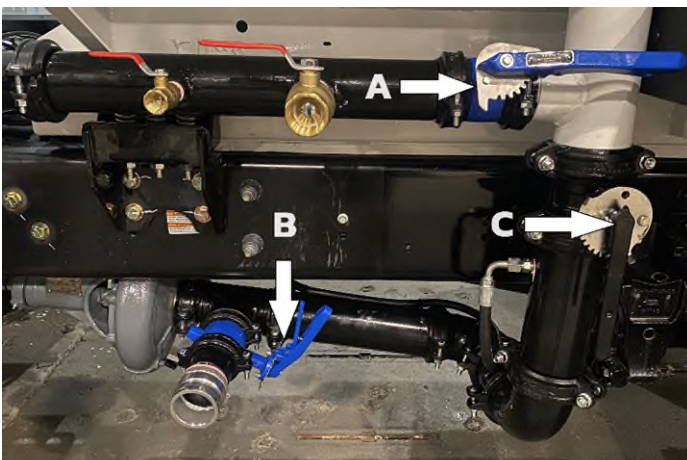

*As an option during purchasing, the vehicle may come with sections of 3-inch suction hose for the creek fill operation. One section will have a strainer to avoid sucking up rocks or debris. They are typically stored on fender trays, beneath the water tank.

1. Begin with all valves CLOSED.
2. Hook up suction hose to the suction valve at "B". (see above reference photo)

CAUTION

TANK SHOULD BE FILLED TO AT LEAST 1/4 FULL TO SAFELY OPERATE PTO.

8. Slowly OPEN the Suction Valve (B) and let the inlet line fill with water from the tank.
9. Slowly CLOSE the Sump Valve (C)" and the tank will begin to fill.
10. Once filled to the desired water level, turn off PTO.
11. CLOSE the Suction Valve (B) and Tank Fill Valve (A).
12. Remove hose from the Suction Valve (B).
13. Return all valves to original CLOSED settings for normal operation.

DISPENSE OPERATIONS

SPRAY HEAD SYSTEM



1. With the truck in park, start the engine.
2. Select a spray head to use and switch it to the "OPEN" position.

CAUTION

AT LEAST ONE SPRAY HEAD SHOULD BE OPEN PRIOR TO TURNING ON THE PTO TO AVOID DAMAGE TO THE WATER PUMP



3. With the engine under 1000 RPMS, toggle PTO to ON or MOBILE to supply power to the water pump.

NOTE

STATIONARY MODE CAN ALSO BE USED IF A PRECISE AREA IS NEEDED TO BE SPRAYED AND CANNON IS NOT INSTALLED.

4. Put the truck into gear or drive, and slowly start driving.
5. Water will begin to spray out of the selected spray head.
6. To increase pressure, increase the RPMs/speed of the truck. To decrease pressure, lower RPMs/speed.

NOTE

AS A SAFETY MEASURE, THE PTO WILL AUTOMATICALLY DISENGAGE WHEN RPMS REACH 1650 (2000 for FORD Models)

TO SWITCH BETWEEN SPRAY HEADS

1. Once the above steps are complete, OPEN the next spray head that is desired, WHILE the previous one is still OPEN.
2. Water will begin to flow from the newly open spray head, as well as the previous spray head.
3. CLOSE old spray head to add pressure to new spray head.

NOTE

OPERATING MORE THAN 2 SPRAY HEADS SIMULTANEOUSLY WILL REDUCE THE SPRAY WIDTH AND FLOW OF ACTIVE SPRAY HEADS

TO SHUT DOWN SPRAY HEAD SYSTEM

(following the previous steps)

1. Ensure one spray head is still OPEN.
2. Switch PTO button to OFF to stop power to water pump.
3. CLOSE spray head to stop the flow of water.

WATER CANNON

CAUTION

WATER TANK MUST BE AT LEAST 1/4 FULL TO AVOID WATER PUMP DAMAGE DURING OPERATION.

1. Make sure that the area around the truck is clear and safe to operate the cannon.
2. With the truck in park, start the engine.
3. Open the "WATER CANNON" switch on the dash or control tower.
4. The PTO for the water cannon can be activated in either MOBILE or STATIONARY modes. Select the mode that is needed.
5. Turn ON Cannon Power by lifting the knob next to the joystick (A). The light will turn on next to it to signal that the power is on.

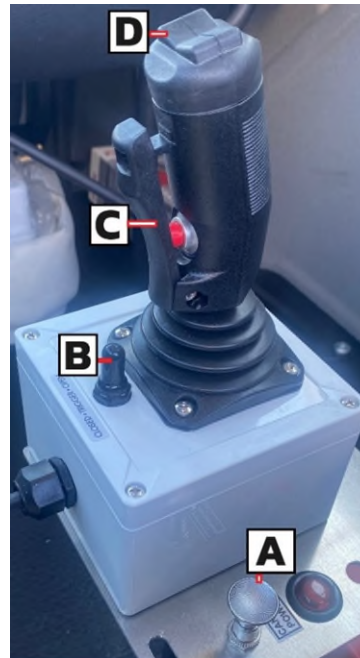

- A – Water Cannon power knob
- B – Closed, Trigger, Open Toggle Switch
- C – Water Cannon trigger
- D – Fogger/Spray Width Control button

6. The direction of the cannon is controlled by the joystick.
7. Cannon can be operated while vehicle is in motion, however PTO will automatically shut off if RPMs reach 1650 (2000 for Ford & Mack).
8. The toggle switch (B) has three selectable positions, "CLOSED", "TRIGGER", and "OPEN".
 - CLOSED – Water will not spray at all.
 - TRIGGER (C) – Water will only spray when trigger is being pulled, when the toggle switch (B) is set to TRIGGER.
 - OPEN – Water will continuously spray from cannon.

NOTE

THE LIGHT COMING ON DOES NOT GUARANTEE POWER TO THE PTO

- Water spray width is adjusted by the thumb button on top of the joystick (D).

CAUTION
KEEP THE VEHICLE AT A SLOW AND STEADY PACE TO AVOID DAMAGE TO THE PTO OR WATER PUMP.

**TO SHUT DOWN WATER CANNON
(following the previous steps)**

- Ensure "WATER CANNON" valve is still OPEN.
- Turn the PTO to "OFF."
- Turn OFF Water Cannon Power on the joystick.
- CLOSE Water Cannon valve.

HOSE & HOSE REEL

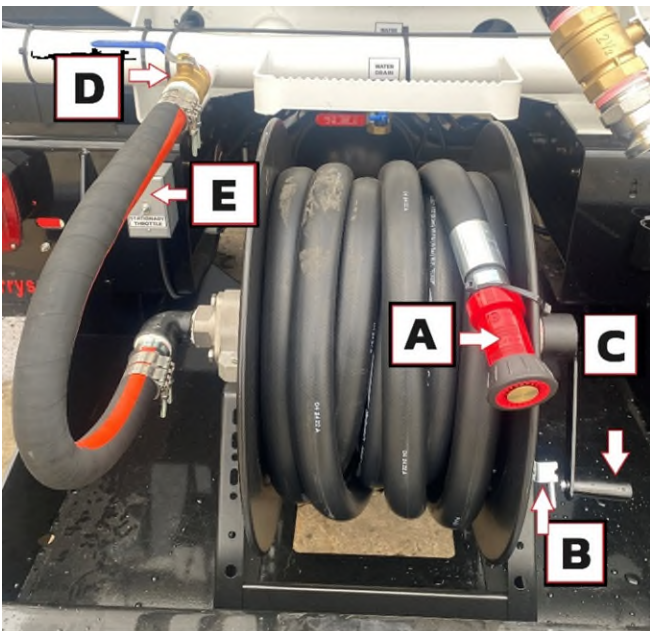

- Ensure the hose nozzle (A) is CLOSED (head rotates to OPEN and CLOSE).
- With the truck parked, and parking brake on, start the engine.

WARNING
THE FOLLOWING WILL PRESSURIZE THE SYSTEM, MAINTAIN CONTROL OF HOSE.

- Turn the PTO to ON or "STATIONARY MODE" inside the cab.
- (FORD & MACK MODELS) Turn ON the Stationary Throttle switch on the rear of the tank to turn on the PTO and engine to correct RPM (E).
- (OTHER MODELS) Use the cruise control switches to set RPM to 1500.
- OPEN the hand valve (D) to allow water to fill the hose from the tank.
- Pull spring loaded locking pin (B) to allow reel to spin freely.
- Unwind or pull the hose (C) to the desired length.
- Adjust the spray width by rotating the hose nozzle.
- When finished, toggle the stationary throttle switch (if installed) to OFF.
- Turn OFF the PTO inside the cab.
- CLOSE the hand valve.
- Reel the hose back up into the reel and lock the reel with spring loaded pin.



DRAIN OPERATIONS

GALLON INDICATOR DRAIN VALVES

There may be up to (2) of these drains installed on the rear of the tank.



Water may need to be drained to meet a safe weight for transportation on highways and/or bridges.

NOTE

IT IS THE OPERATOR'S RESPONSIBILITY TO COMPLY WITH LAWS AND REGULATIONS REGARDING THE WEIGHT OF THE VEHICLE THAT THEY ARE OPERATING.

To open these drain valves, rotate the knob so that it is in line, or parallel to the drain. If the water level is higher than the drain, water will flow out until it reaches drain height.

To close the drain valves, rotate the knob so that it is perpendicular to the drain, or sideways.

WATER DRAIN VALVES



There are (4) Drain valves located on the truck. (1) on the front spray bar, (1) on the rear spray bar, (1) on the water pump, and (1) large drain on the rear bottom of the tank.

Front Spray Bar Drain Valve



Water Pump Drain Valve



Rear Spray Bar & Tank Drain Valves



Opening these will allow water to drain completely from the tank and spray bars. To avoid ice damage, all water should be drained, and valves left open during winter months, and when truck is idle for extended periods of time.

To OPEN these drain valves, rotate the knob so that it is in line, or parallel to the drain. If there is water inside of the tank it will start to flow out of the drain.

To CLOSE the drain valves, rotate the knob so that it is perpendicular to the drain, or sideways.

Valves should be closed when transitioning back to normal operation.

HI RAIL OPERATION

(If installed)

The Hi Rail system allows vehicles to drive on train tracks using deployable train wheels.

TO DEPLOY HI RAIL TRAIN WHEELS:

1. Line the vehicle up correctly over the tracks on a track crossing.
2. Put the vehicle in park and leave the engine running.
3. Turn on the PTO, located on the dashboard.

4. Locate the rail gear hydraulic knob. It is located on the driver side of the vehicle, by the water pump assembly.



5. Pull the knob out to direct the hydraulics to the rail gear.



- 6. Locate the front wheel lever located behind the front bumper (B). Push that lever towards the truck to lower the wheels (A) down to the track. Keep pushing until the front wheels are at their fullest position.



- 7. Locate the rear wheel levers (B) on the rear driver side of the vehicle. Alternate pushing them in one at a time to line them up with the track while extending the rear wheels (A) down to the track. Extend them to their fullest position.

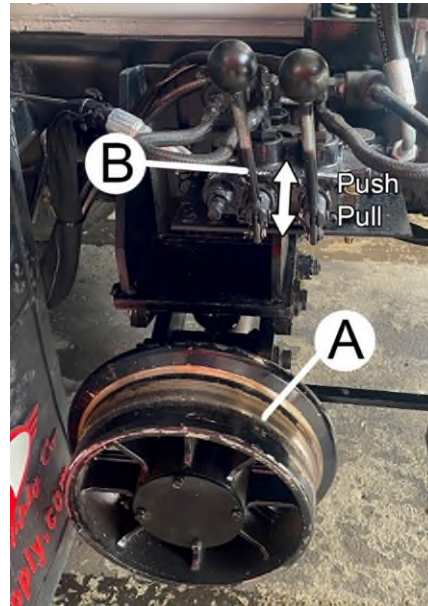

- 8. To spray water while driving on the rail, push the hydraulic knob back in to supply hydraulics back to the water system.



9. Inside of the truck cab, locate the rail gear air brake switch on the dashboard. Toggle this switch to ON to transfer hydraulic brake pressure to the train wheels instead of truck wheels.



10. Make sure that the steering wheel and the wheels are pointed straight (some vehicles come with a velcro safety reminder to bridge between the steering wheel and steering column).



11. Put the vehicle in drive and proceed with caution.
12. Use normal spray operations to spray water if needed.

TO RETRACT HI RAIL TRAIN WHEELS:

1. Slow the vehicle to a stop at a railway crossing or a location where the wheels could drive over the rails and put the vehicle in park.
2. Remove the velcro safety device from the steering wheel column.



3. Locate the rail gear air brake switch on the dash and turn the switch to OFF, transferring the hydraulic brake pressure back to the truck wheels.



4. Get out of the vehicle and locate the hydraulic knob by the water pump and pull it out to put hydraulic pressure to the rail gear.



5. Locate the rear wheel control levers (B) on the rear driver side of the vehicle. Alternate pulling them one at a time, raising the rear trail wheels (A) from the track and back up and into the body. Keep pulling until they are retracted to their full position.

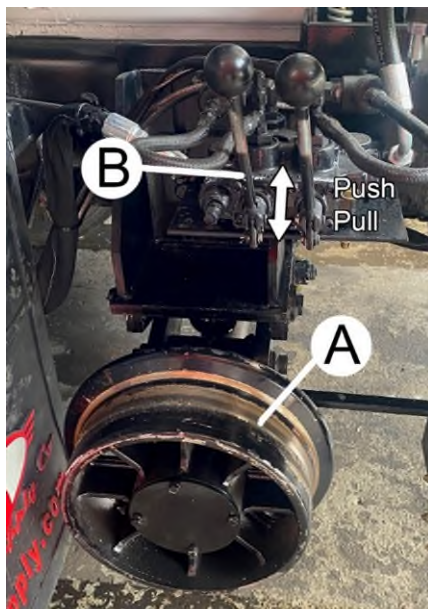

6. Locate the front wheel control lever behind the front bumper and pull that lever until the train wheels retract up to their full position.



7. Push back in the hydraulic knob on the side of the truck to put hydraulic pressure back to the spray system.



SECTION 4

Maintenance & Lubrication

Due to the numerous jobs and purposes, varying environments and climates, and importance to safety, routine maintenance is highly recommended. Regular maintenance keeps the water trucks functioning correctly and at optimum efficiency. The following tasks can help prevent breakdown and keep the truck on the job when you need it most.

NOTE

FOR THE MOST ACCURATE MAINTENANCE FOR A SPECIFIC SYSTEM, REFER TO THE PRODUCT SPECIFIC USER MANUAL

DAILY SAFETY MAINTENANCE

Tires – Check for proper inflation and tread depth.

Brake System – Routine inspections on brake pads and calipers for safe operation.

Lights – Check all lights are working and functioning correctly.

Fluids – Check engine oil, coolant, hydraulic fluid, and wiper fluid are at proper levels.

Hoses – Check for leaks, cracks, and that they are fully secure.

WATER PUMP ROUTINE MAINTENANCE

A well-maintained pumping system will extend the life of the unit and require fewer repairs.

This means less down time, which could be extremely critical when a constant delivery of

liquid is required. A routine maintenance and inspection schedule should be set up on a weekly, quarterly, and annual basis with records kept of these actions.

The following is a breakdown list of maintenance that is recommended to be completed:

WEEKLY MAINTENANCE (~250 miles)

Bolt Torque: During operation, bolts can become loose. Check to make sure bolts are lined up with correct bolt torque markings. If not, retighten them to the correct torque.

Vibration: All rotating machines can be expected to produce some vibration. However, excessive vibration can reduce the life of the unit. If the vibration seems excessive, discontinue operation, determine the cause, and correct the issue.

Noise: When the unit is operating under load, listen closely for unusual sounds that might indicate the unit is in distress. Determine the cause and correct the issue.

Operating Temperature: During operation, heat is dissipated from the pump bearings and the driver. After a brief time, the surface of the pump bracket will be warm (as high as 150°

degrees F), which is normal. If the surface temperature of the pump bracket or driver is excessive, discontinue operation, determine the cause of the temperature rise, and correct the issue. Bearings will run hotter for a brief run-in period after packing which is normal. However, worn bearings will cause excessive temperatures and need to be replaced. The pump unit is cooled by the water following through it and will normally be at the temperature of the pumping liquid.

Rope Packing: After a brief period of operation, verify that the stuffing box area and gland are not hot. If heating is detected, loosen the gland nuts evenly until water is just running out of stuffing box in a DROPLET form. Water must not be streaming or spraying out (water drops should be 40-60 drops a minute). Verify cool operation periodically. Adjust gland nuts EVENLY as necessary for lubrication and cooling of the packing. If packing has been tightened to the limit of the packing gland travel, additional packing is necessary.

CAUTION

IF THE UNIT IS EQUIPPED WITH A ROPE SEAL WATER PUMP THAT REQUIRES A MINIMUM DRIP. DO NOT OVER TIGHTEN THE SEAL.

Mechanical Seal: Inspect seal for leakage. There should be no leakage from mechanical seal.

Suction Line: Inspect line and screen for flow obstruction.

QUARTERLY (~3,000 miles)

Pump and Piping Connections: Inspect all system piping connections for leakage or misalignment. Misalignment of pipe connections to the pump will put excessive strain on the pump case and can cause damage to internal components of both the pump and motor. If stress on the pump case is suspected, adjust pipe supports to correct. For flange connections, misalignment can be checked by shutting down the pump and removing the pipe flange bolts on the pump connections. If the mating flanges come apart or shift, there is pressure at the connection(s) and adjustments should be made to the piping supports until flanges mate without force. This procedure can be done throughout the piping system.

- Check pump foundation for integrity and ensure all hold-down bolts are secure.
- Inspect packing or mechanical seal for possible replacement. Examine shaft sleeve, if present, for wear and replace it if necessary.
- Inspect pumping plant panel for signs of wear (i.e.: replace pitted contactors, etc., as needed).
- Check pump and/or motor bearings for signs of wear. Repair or replace as required.

ANNUALLY (~12,000 miles)

- Inspect the pump and entire pumping system for signs of wear.
- Inspect system valves and screens.
- Check electric motor windings for degradation, rewind if necessary.
- Inspect impeller, volute case, and seal chamber for signs or excessive wear or corrosion.
- Liquid End of pump requires no lubrication.
- Drain compressor to reduce condensation.

Wear rings, packing rings, and models using a mechanical shaft seal, are lubricated by the liquid being pumped.

CAUTION

DO NOT RUN DRY! LUBRICATION IS NEEDED TO AVOID DAMAGE.

BEARING FRAME: Add approximately 2 ounces of a lithium based NGLI No. 2 extra pressure ball bearing grease to each bearing during quarterly inspection.

NOTE

GREASE FITTING IN PACKING AREA IS FOR PRIMING

HOSE REEL: Grease hose reel quarterly to avoid friction and rust build up.

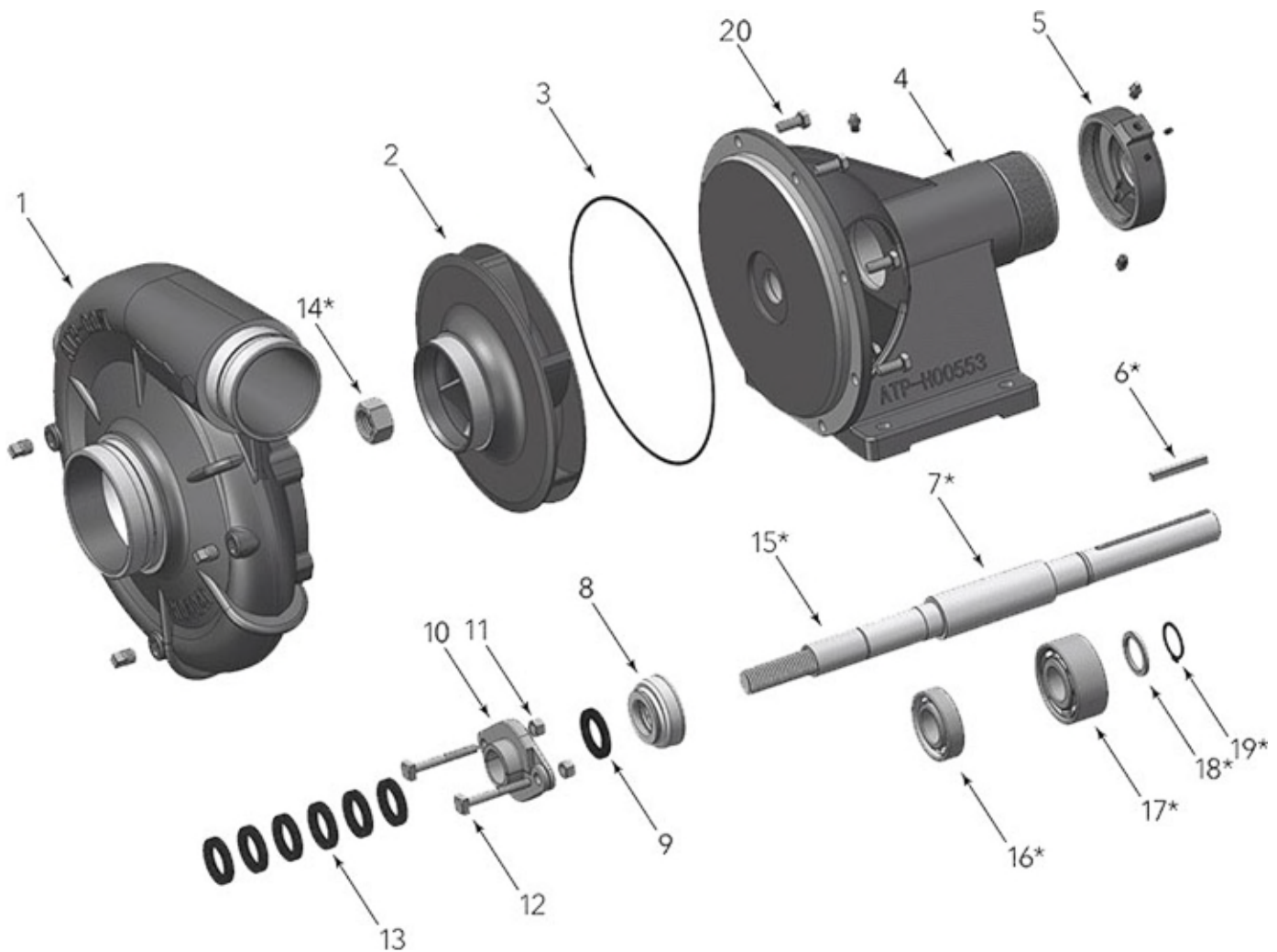
WATER PUMP DIAGRAM

- | | |
|----------------------------|------------------------|
| 1. Volute | 11. Packing Gland Nut |
| 2. Impeller | 12. Packing Gland Bolt |
| 3. Volute O-ring | 13. Rope Packing |
| 4. Rope Seal Bearing Frame | 14. Impeller Lock Nut |
| 5. Outer Bearing Cap | 15. Shaft Sleeve |
| 6. 1/4" Key | 16. Ball Bearing |
| 7. Shaft Kit | 17. Ball Bering |
| 8. Inner Bearing Cap | 18. Shaft Thrust Ring |
| 9. Water Slinger | 19. Retaining Rin |
| 10. Packing Gland Set | 20. Hex Cap Screw |

PTO MAINTENANCE

Upon delivery of the vehicle and initial operation, check for leaks from any location. The PTO should be serviced at the same intervals as the transmission. The transmission maintenance should be completed as recommended by the vehicle manufacturer. The PTO is part of a system that includes the drive shaft which should also be checked at the same time.

Within the first week of use, recheck the installation of the PTO. Check for leaks and loose mounting hardware (studs, cap screws, nuts). Recheck the cable or lever connections for proper adjustment and tighten any loose connections. At regular maintenance intervals, check adjustments and lubricate moving parts, tighten and repair the connections, mounting hardware, cable, or lever linkages.

Before daily use:

- Check for any leaks.
- Check the transmission oil level.
- Check for any dents or damage to PTO or driveshaft system.

Every 100 usage hours:

- Recheck the installation of the PTO.
- Check for leaks and loose mounting hardware (studs, cap screws, nuts).
- Recheck and tighten any loose connections.
- Check adjustments and lubricate moving parts.

- Check and retighten any bolts, linkages, or mounting hardware.
- Apply anti-seize grease to output shaft that mounts to water pump.

WATER CANNON (if equipped)

The complete monitor and control system should be inspected during each apparatus check. Careful inspection for damage to the monitor and nozzle is especially important after each use.

Visually inspect each system component including the Monitor, Nozzle, Joystick, Valve and Wire Harnesses.

- Operate each function (left-right, up-down, jet-fog) from each control point.
- Flow water to check the nozzle pattern. If the pattern is disrupted, use the nozzle flush feature to clear the debris. To flush the nozzle, while spraying water from the cannon, open the spray pattern the full way, then close it to the tightest pattern, and repeat again. If the obstruction remains, remove the nozzle, and check for debris lodged between the nozzle stem and body.
- During nozzle flow test, inspect monitor swivel joints for leaks.
- Inspect all exposed wiring for signs of damage.

Drain water cannon after use by opening installed petcock valve. Stagnant water may cause rust, corrosion, or cracks when frozen.

WINTERIZING/FREEZE PREVENTION

Frozen water inside of the system can lead to considerable damage. To prevent damage please consider the following:

- Water Tank – Drain the water tank as much as possible, parking on an incline with the drain at the lowest point.
- Drain Valves – Open any drain valves installed on the spray system.
- Water Cannon – Open the drain valve on the cannon and open the nozzle to allow air flow.
- Hose – Remove hose reel supply hose and leave ball valve open. Open the hose nozzle and leave it open to drain.

SPARE PARTS

The number and type of spare parts kept on hand at any pump site is dictated by the severity of the service in which the pump is used. It is recommended that the following spare parts be kept on-site as a minimum back-up to service pump and reduce down-time. Parts shown do not apply to all models. Check your model/style when selecting spare parts.

- Mechanical shaft seal
- Packing set and packing hooks
- Shaft sleeve(s)
- Impeller wear ring
- All gaskets and O-Rings that are required for one entire pump assembly.
- Retaining rings

- Additional diaphragms for the air valves

If having a pump non-operational has severe consequences, a back-up pump should be considered. Otherwise, a backup impeller, volute case, bearings, and shaft, would be prudent.

If pump is to be out of service for an extended period, such as the winter months, the following storage procedures should be followed:

- Remove exterior dirt and grime or any substance that may trap moisture. Exposed metal is subject to oxidation, prime and repaint if necessary.
- Flush suction and discharge lines. Check for leaks and replace any worn gaskets.
- Remove the lowest plug in the pump, drain the pump casing, and suction and discharge lines.
- Lubricate the bearings.
- If possible, keep the unit clean and dry during storage period to guard against corrosion.
- Seal all open ports to keep out foreign objects such as insects, rodents, dust, and dirt.
- Rotate driver shaft periodically to prevent freeze-up of internal components.
- Shelter the pump from the elements when possible.

BOLT TORQUE SPECIFICATION CHART

Part	Bolt Size	Torque
Upper Tie Downs	5/8" Grade 8	212 ft/lbs.
Lower Tie Downs	5/8" Grade 8	212 ft/lbs.
Tie Down Spring Tension	5/8" Grade 8	5/8" of spring compression
Ladder	3/8" Stainless Steel	19 ft/lbs.
Water Pump Brace	1/2" Grade 8	106 ft/lbs.
Water Pump	7/16" Grade 8	70 ft/lbs.
Rear Bumper	5/8" Grade 8	212 ft/lbs.
Compressor Mount (Ford)	5/8" Grade 8	212 ft/lbs.
PTO Bolts (TG Series)	M10x1.5	40-45 ft/lbs. 6 Bolt Pad 50-55 ft/lbs. 8 Bolt Pad
PTO Bolts (CS Series)	M10x1.5	40-45 ft/lbs. 6 Bolt Pad 50-55 ft/lbs. 8 Bolt Pad
PTO Bolts (A20 Series)	M10x1.5	45 ft/lbs.
PTO Bolts (A30 Series)	M10x1.5	45 ft/lbs.
PTO Bolts (F20 Series)	M10x1.5	Cap Screws 30 ft/lbs. Stud Nuts 22 ft/lbs.

NOTE

ALL TORQUED BOLTS ARE TO BE MARKED AFTER BEING TIGHTENED TO SPECIFICATIONS.

CAUTION

ALL BOLTS SHOULD BE RECHECKED TO MEET TORQUE SPECS EVERY 500 MILES

SECTION 5

Schematics

Water Tank 4k Gal Gen IV – Electric Diagram	Page 32
Water Tank 4k Gal Gen IV – Airline Diagram	Page 33
Air Compressor Wiring/Air Connection	Page 34
Water Truck Harness/Wiring Diagram 1	Page 35
Water Truck Harness/Wiring Diagram 2	Page 36
Allison Transmission, PTO Wiring, Water Truck	Page 37
Allison PTO Wiring, Automatic Transmission	Page 38
Mack MD PTO Wiring	Page 39
Mack Water, Stationary Throttle	Page 40
Ford F650 Water Truck Wiring Diagram	Page 41
Ford F650 & F750 Wire Harness Schematic	Page 42
Ford 2 on 2 Compressor Layout	Page 43

CAUTION

PLEASE CONTACT CURRY SUPPLY BEFORE ATTEMPTING ANY CHANGES TO THE ELECTRICAL SYSTEMS. DOING SO MAY CAUSE EQUIPMENT DAMAGE OR VOID WARRANTY.

NOTE EXTENSIONS WIRES ARE BLACK AND GREEN.
BLACK - GROUND
GREEN - HOT

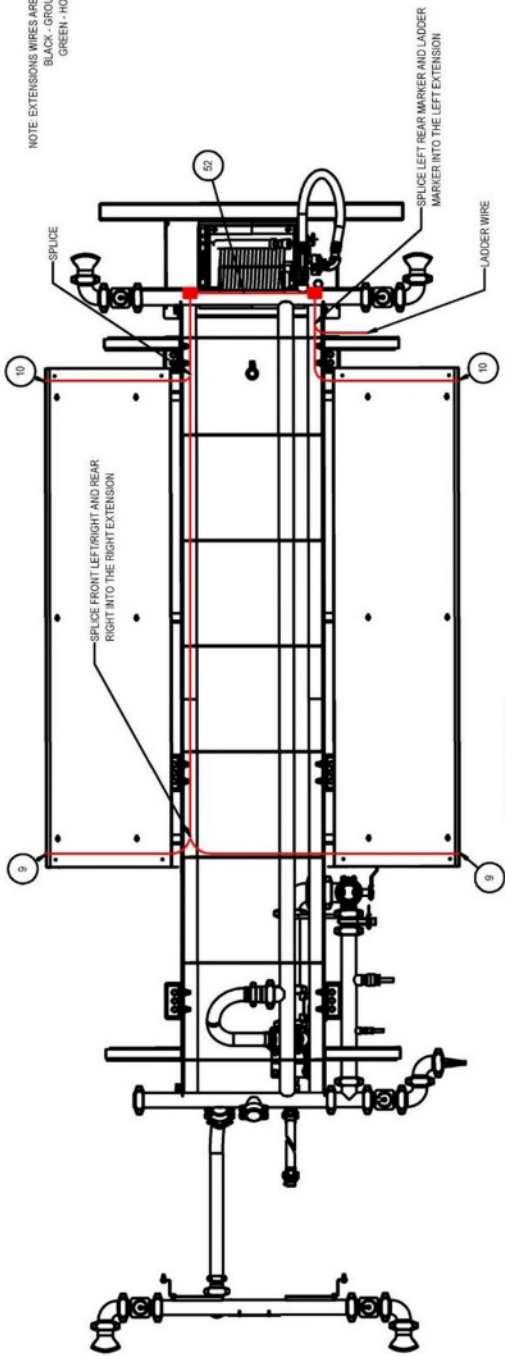

1/4\"/>

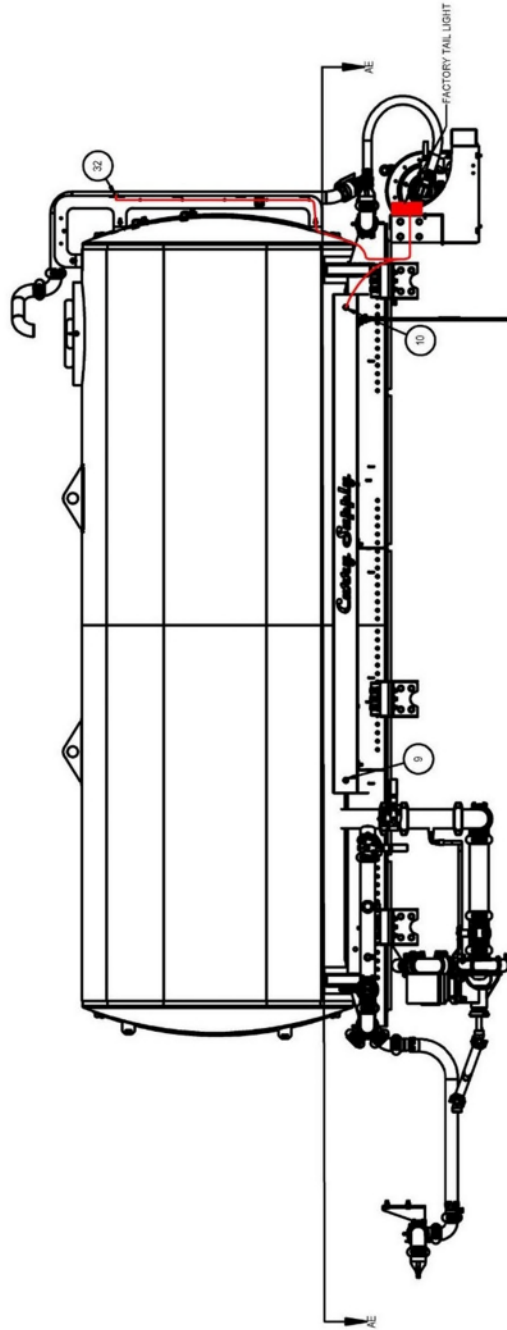

		NAME	DATE
		MODEL BY:	09/17/19
CONTROLLED DOCUMENT		DRAWN BY:	09/17/19
		ENG. APPR.	
TITLE: WATER TANK, 4,000 GAL. GEN IV - ELECTRIC DIAGRAM		MFG. APPR.	
		G.A.	
COMMENTS:		SIZE	1815-1000
		REV	0
PROPRIETARY AND CONFIDENTIAL THE INFORMATION CONTAINED IN THIS DRAWING IS THE SOLE PROPERTY OF CURRY SUPPLY COMPANY. ANY REPRODUCTION OR TRANSMISSION OF THIS DRAWING WITHOUT THE PERMISSION OF CURRY SUPPLY COMPANY IS PROHIBITED.		PART NO.	C
			SHEET 3 OF 5

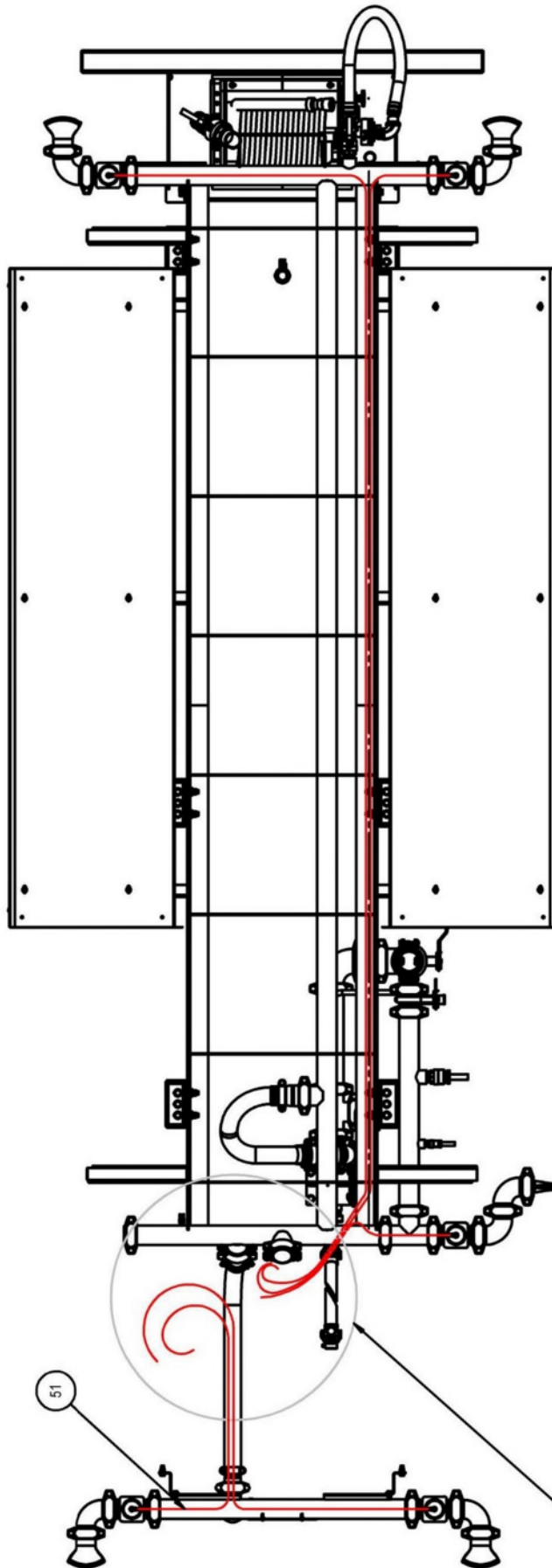

1/4" AIR LINE DIAGRAM
SECTION L-L
SCALE 1 : 20

RUN LINES THROUGH THE BOTTOM OF THE CAB INTO THE CONTROL SWITCHES.
NOTE: DIFFERENT CHASSIS MODELS MAY HAVE DIFFERENT SWITCH LOCATIONS.
ENTER THE CAB AT THE BEST LOCATION FOR THE SWITCH LAYOUT THAT DOES NOT REQUIRE ANY SPLICING.

		TITLE: WATER TANK, 4,000 GAL. GEN IV - AIR LINE DIAGRAM	SIZE PART NO. B 1815-1000	REV 0	SHEET 2 OF 5
NAME	DATE				
MLC	09/17/19				
MLC	09/17/19				
ENG APPR.					
MFG APPR.					
Q.A.					
COMMENTS:					

PROPRIETARY AND CONFIDENTIAL
 THE INFORMATION CONTAINED IN THIS DRAWING IS THE SOLE PROPERTY OF CURRY SUPPLY COMPANY. ANY REPRODUCTION IN PART OR AS A WHOLE WITHOUT THE WRITTEN PERMISSION OF CURRY SUPPLY COMPANY IS PROHIBITED.

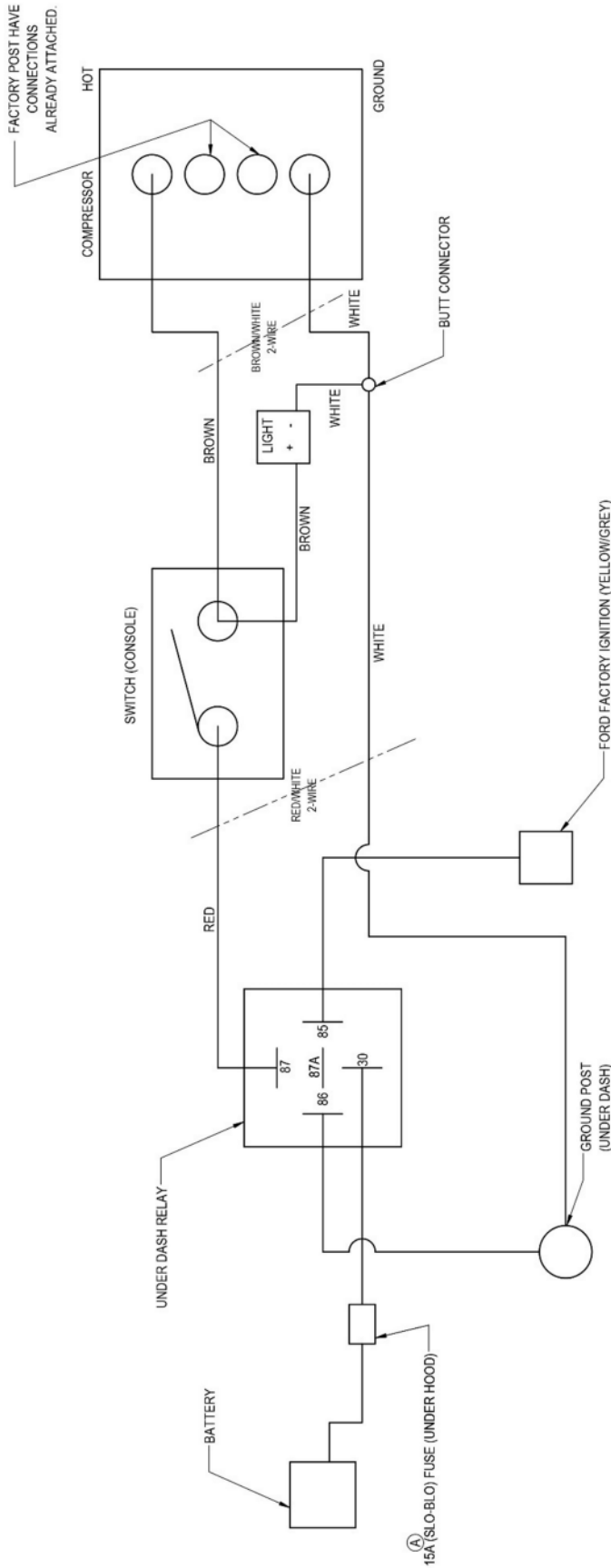

ZONE	REV.	DESCRIPTION	DATE	APPROVED	ECR #
B4	A	UPDATED FUSE SIZE AND TYPE	10/04/19	MLC	N/A

Curry Supply Co.

MODEL BY: MLC DATE: 08/05/18

DRAWN BY: MLC TITLE: ON ROAD WATER AIR COMPRESSOR WIRING/AIR CONNECTION

ENG APPR.:

MFG APPR.:

G.A.:

COMMENTS:

SIZE: **B** PART NO.: 1630-1900 REV:

SHEET 1 OF 1

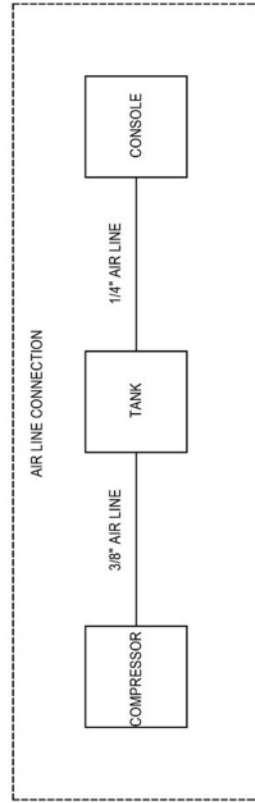

PROPRIETARY AND CONFIDENTIAL
 THE INFORMATION CONTAINED IN THIS DRAWING IS THE SOLE PROPERTY OF CURRY SUPPLY COMPANY. ANY REPRODUCTION IN PART OR AS A WHOLE WITHOUT THE WRITTEN PERMISSION OF CURRY SUPPLY COMPANY IS PROHIBITED.

Item No.	QTY.	Part No.	Stock Desc.	Units
1	2	ADO-PT1937	Connector 5 way 5 pin for Chevrolet Tail Light GM	ea
2	10	0747509	.157", 16-14 AWG, FEMALE BULLET CONNECTOR	ea
3	265	0708152	3/8" POLYETHYLENE SLIT WIRE LOOM	in
4	310	0708151	1/4" POLYETHYLENE SLIT WIRE LOOM	in
5	140	0700457	14 GAUGE RED	in
6	125	0719096	14 GAUGE GREEN	in
7	775	0700458	14 GAUGE WHITE	in
8	745	5121919	14 GAUGE BROWN	in
9	1	76455A22	Electrical Tape, 3M Scotch Super 33+, 3/4" Wide, 76 Feet Long, Black	ea
10	5	0749243	FASTENAL BAWG-BAWG'S SHRINK TUBE W/ ADHESIVE, 2" LONG	ea
11	2	58694	16-14 AWG Power Phases #10 Sturd Blue Polyolefin Sealed Crimp Ring Terminal	ea
12	3	34318	TE CONNECT PARALLEL SPLICES BAWG	ea
13	2	34319	TE CONNECT PARALLEL SPLICES 6AWG	ea

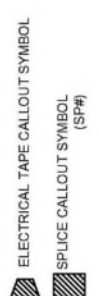

- NOTES:
 REFERENCE DOCUMENT:
 -BUILD CABLE HARNESS IN ACCORDANCE WITH IPC-620
 1) SPLICING WIRES SHALL BE DONE AN 1-1/2 BEFORE BREAKING OUT THE HARNESS
 2. ITEM NO. 5-10,12,13 NOT SHOWN IN ASSEMBLY
 3. ALTERNATE PART NO. ARE ALLOWED ASLONG AS THE ALTERNATE PART PROVIDES THE SAME FORM FIT AND FUNCTION. IF UNSURE PLEASE CONTACT CURRY SUPPLY ENGINEERING
 4) PLACE LABELS WITH THE FOLLOWING CALLOUTS THAT POINTS TO EACH COMPONENT
 5 FOLLOW GUIDELINES/RECOMMENDATION OF MANUFACTURE WHEN INSTALLING EACH PLUG, JACK, SPLICE, CONNECTOR, AND TERMINAL
 6 SHRINK ITEM NO. 10 OVER TOP EACH SPLICE THAT IS MADE
 7) WRAP ITEM NO. 9 AROUND EACH LOCATION
 8) WIRE STUFF SP4,SP5 WITH 1 EXTRA 14AWG ONCE THE SPLICE HAS BEEN CRIMPED TRIM EXCESS WIRE FLUSH

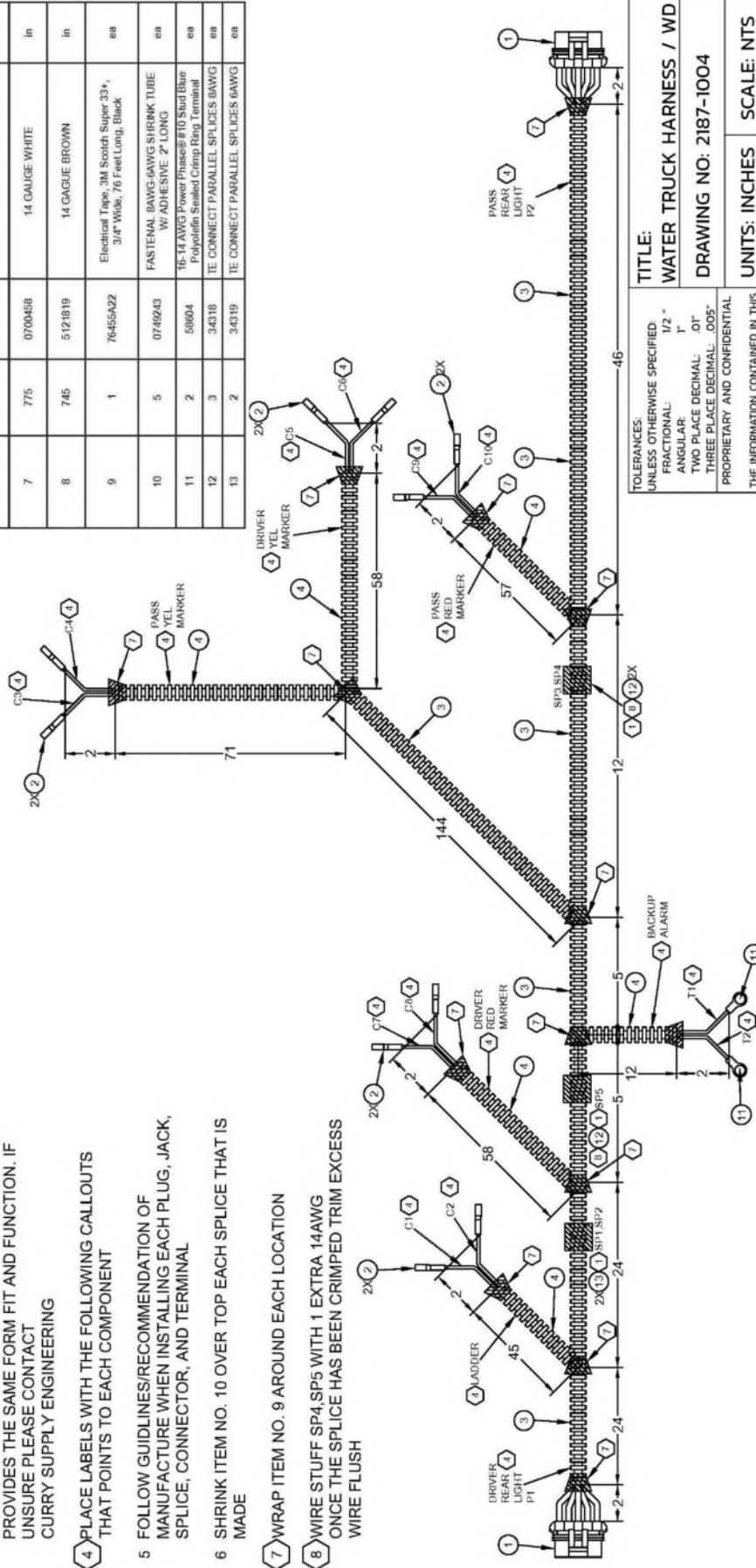

TITLE: WATER TRUCK HARNESS / WD
DRAWING NO: 2187-1004
UNITS: INCHES **SCALE:** NTS
MODEL BY: JS 01/24/23
DRAWN BY: JS 01/24/23

TOLERANCES:
 UNLESS OTHERWISE SPECIFIED:
 FRACTIONAL: 1/2"
 ANGULAR: 1°
 TWO PLACE DECIMAL: .01"
 THREE PLACE DECIMAL: .005"
 PROPRIETARY AND CONFIDENTIAL

THE INFORMATION CONTAINED IN THIS DRAWING IS THE SOLE PROPERTY OF CURRY SUPPLY CO. ANY REPRODUCTION IN PART OR AS A WHOLE WITHOUT THE WRITTEN PERMISSION OF CURRY SUPPLY CO IS PROHIBITED.



LABEL	DESCRIPTION	DESCRIPTION	DESCRIPTION	DESCRIPTION	DESCRIPTION	DESCRIPTION	DESCRIPTION
P1	DRIVER REAR TAIL LIGHT	HARNESS TIE IN	LADDER MARKER LIGHT V-	LADDER MARKER LIGHT V+	PASSENGER SIDE YELLOW MARKER V-	PASSENGER SIDE YELLOW MARKER V+	DRIVER SIDE YELLOW MARKER V-
P2							DRIVER SIDE YELLOW MARKER V+
C1							DRIVER SIDE RED MARKER V-
C2							DRIVER SIDE RED MARKER V+
C3							PASSENGER SIDE RED MARKER V-
C4							PASSENGER SIDE RED MARKER V+

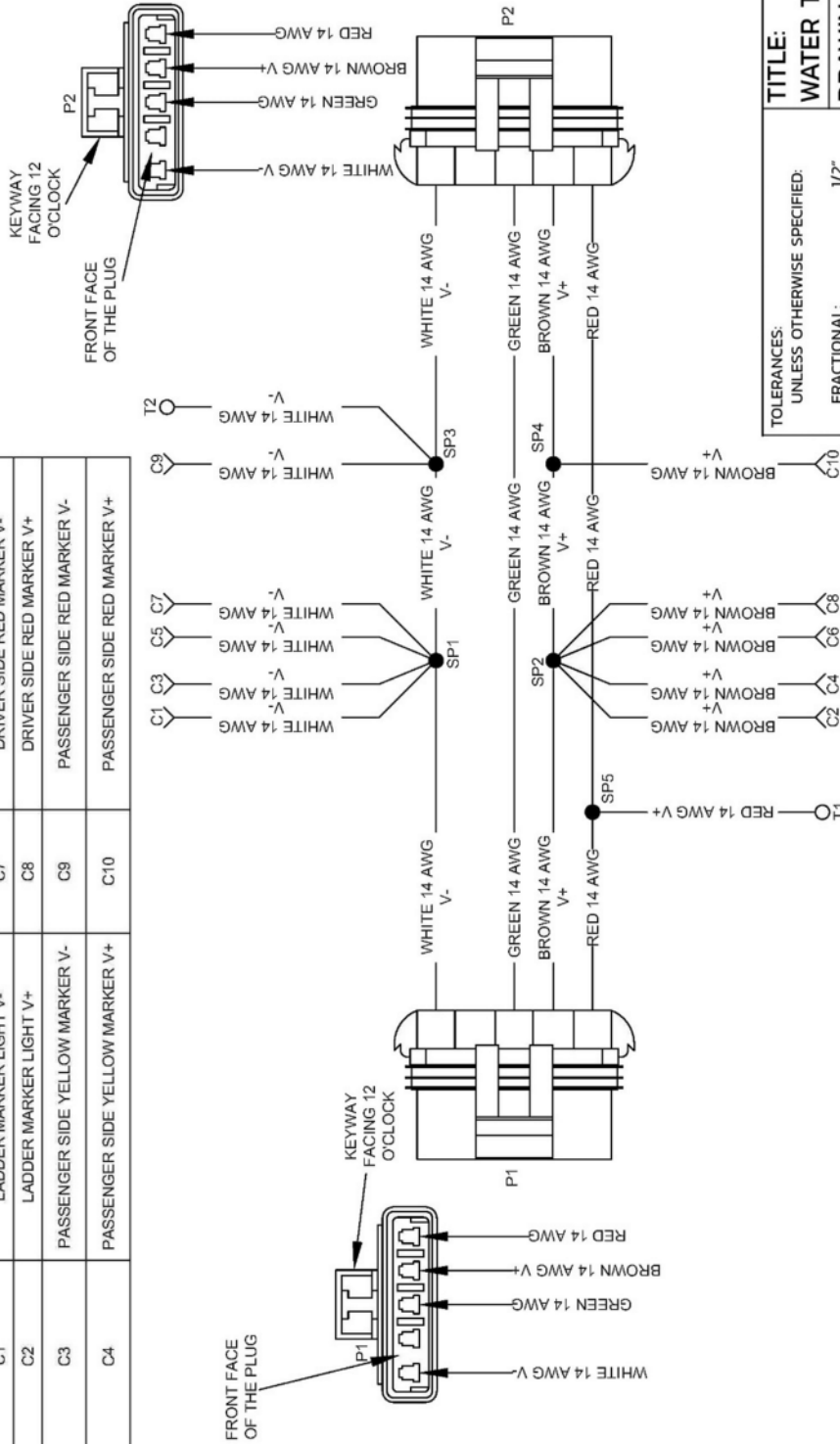

TITLE:		WATER TRUCK HARNESS/WD	
DRAWING NO. 2187-1004		SCALE: NTS	
REV: 0		MODEL BY: JS 01/24/23	
UNITS: INCHES		DRAWN BY: JS 01/24/23	
TOLERANCES: UNLESS OTHERWISE SPECIFIED: FRACTIONAL: 1/2" ANGULAR: 1" TWO PLACE DECIMAL: .01" THREE PLACE DECIMAL: .005" PROPRIETARY AND CONFIDENTIAL THE INFORMATION CONTAINED IN THIS DRAWING IS THE SOLE PROPERTY OF CURRY SUPPLY CO. ANY REPRODUCTION IN PART OF AS A WHOLE WITHOUT THE WRITTEN PERMISSION OF CURRY SUPPLY CO IS PROHIBITED.			

1000/2000 SERIES (2K)
 12 PIN CONNECTOR
 INPUT: WIRE 143
 OUTPUT: WIRE 150

3000/4000 SERIES (2K / 4K)
 12 PIN CONNECTOR
 INPUT: WIRE 143
 OUTPUT: WIRE 130

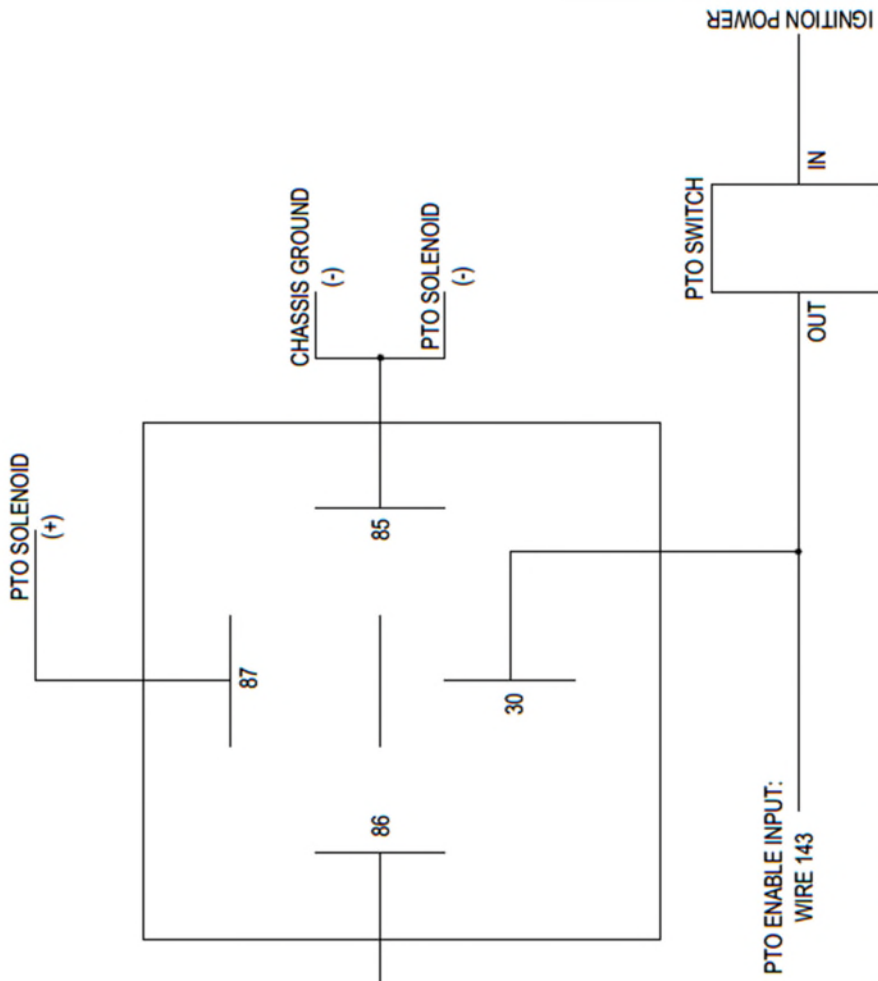

NOTE: RELAY IS MOUNTED UNDER THE HOOD ON THE FIREWALL.

JOB NUMBER	UNLESS OTHERWISE SPECIFIED:	NAME	DATE
PART NO.	DIMENSIONS ARE IN INCHES	MLC	02/19/20
QUANTITY	TOLERANCES: FRACTIONAL ± 1/8"		
CUSTOMER	ANGULAR: MACH ± BEND ± 1°		
DESIGN STATUS	TWO PLACE DECIMAL ±.01		
THICKNESS	THREE PLACE DECIMAL ±.005		
UNITS	ALL TOLERANCES ARE ± 1/8" UNLESS NOTED.		
APPLICATION	MATERIAL		
	Process		
	DO NOT SCALE DRAWING		

	
TITLE: PTO WIRING, ALLISON TRANSMISSION, WATER TRUCK	
SIZE	REV
A	1630-2900
SHEET 1 OF 2	

CONTROLLED DOCUMENT

ENGINEER: _____
 DATE: _____

PROPRIETARY AND CONFIDENTIAL

THE INFORMATION CONTAINED IN THIS DRAWING IS THE SOLE PROPERTY OF CURRY SUPPLY COMPANY. ANY REPRODUCTION IN PART OR AS A WHOLE WITHOUT THE WRITTEN PERMISSION OF CURRY SUPPLY COMPANY IS PROHIBITED.



DUEL PTO
ALLISON AUTO
1-SWITCH

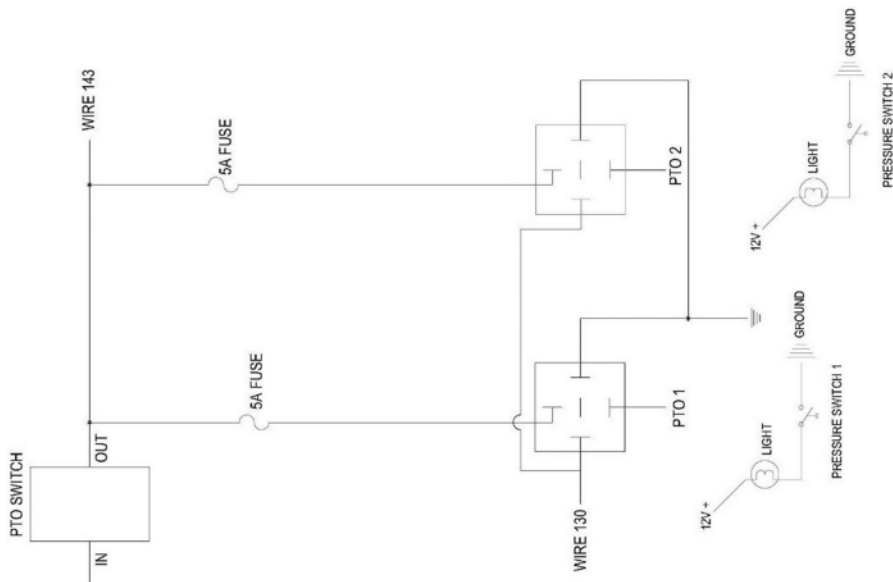

DUEL PTO
ALLISON AUTO
2-SWITCH

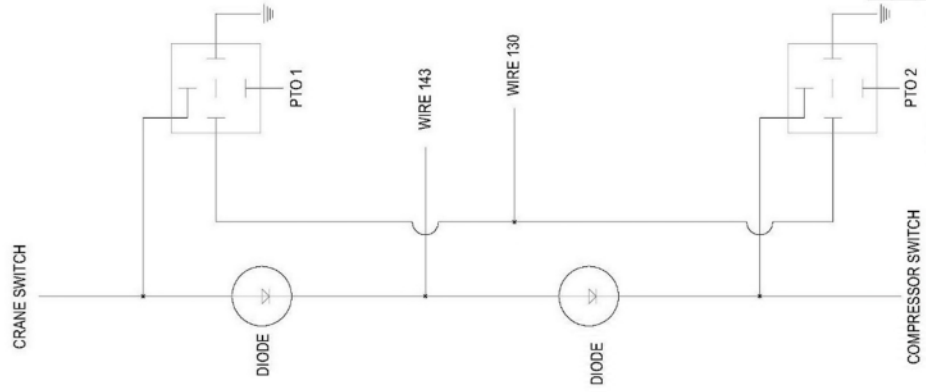

DIODE ASSEMBLY
21688



CONTROLLED DOCUMENT



TITLE: ALLISON PTO WIRING	
AUTOMATIC TRANSMISSION	
SIZE: B	DRAWING NO. 1630-2900
REV	
DRAWN BY: MLC 2/21/20	

PROPRIETARY AND CONFIDENTIAL
THE INFORMATION CONTAINED IN THIS DRAWING IS THE SOLE PROPERTY OF CURRY SUPPLY COMPANY. ANY REPRODUCTION IN PART OR AS A WHOLE WITHOUT THE WRITTEN PERMISSION OF CURRY SUPPLY COMPANY IS PROHIBITED.

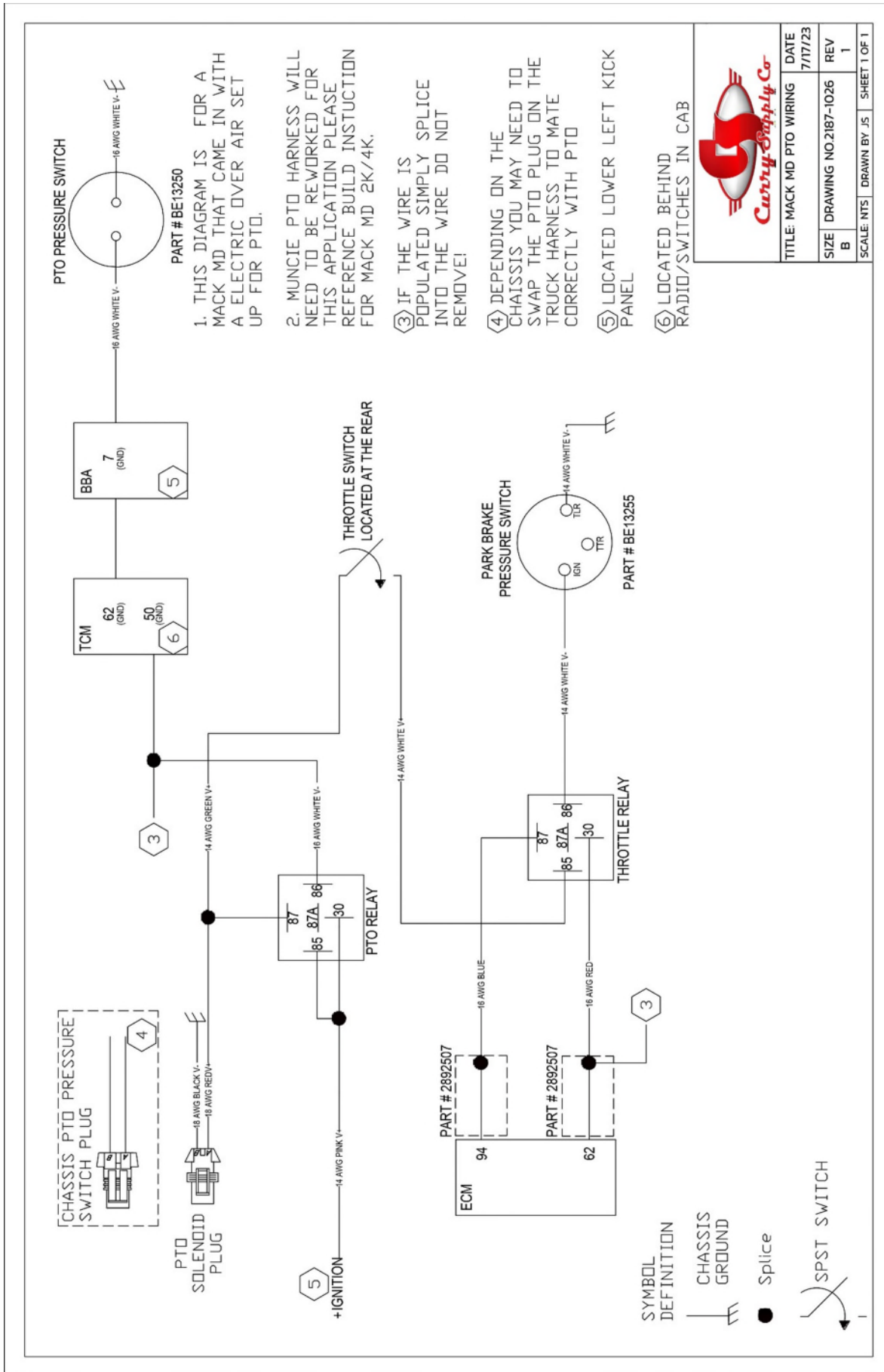

		TITLE: MACK MD PTO WIRING	DATE: 7/17/23
		SIZE: B	REV: 1
DRAWING NO. 2187-1026		SCALE: NTS	
DRAWN BY: JS		SHEET 1 OF 1	

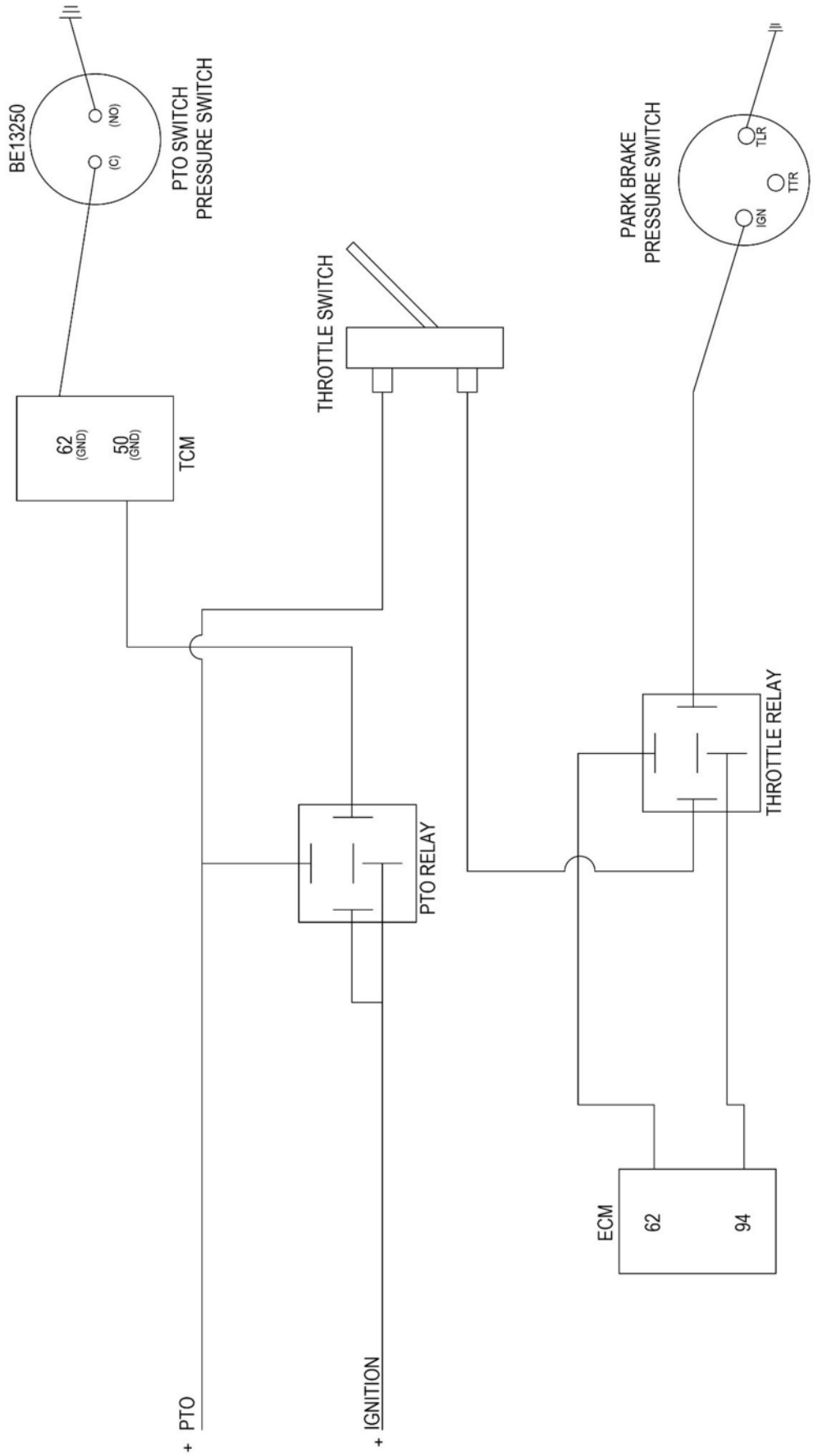

MODEL BY:	LS	DATE	8/16/2022
DRAWN BY:	LS	DATE	8/16/2022

PROPRIETARY AND CONFIDENTIAL
 THE INFORMATION CONTAINED IN THIS DRAWING IS THE SOLE PROPERTY OF CURRY SUPPLY COMPANY. ANY REPRODUCTION IN PART OR AS A WHOLE WITHOUT THE WRITTEN PERMISSION OF CURRY SUPPLY COMPANY IS PROHIBITED.

TITLE:	Mack Water, Stationary Throttle
SIZE	DRAWING NO. 1630-3700
REV	0
SCALE:	1:2
WEIGHT:	SHEET 1 OF 1



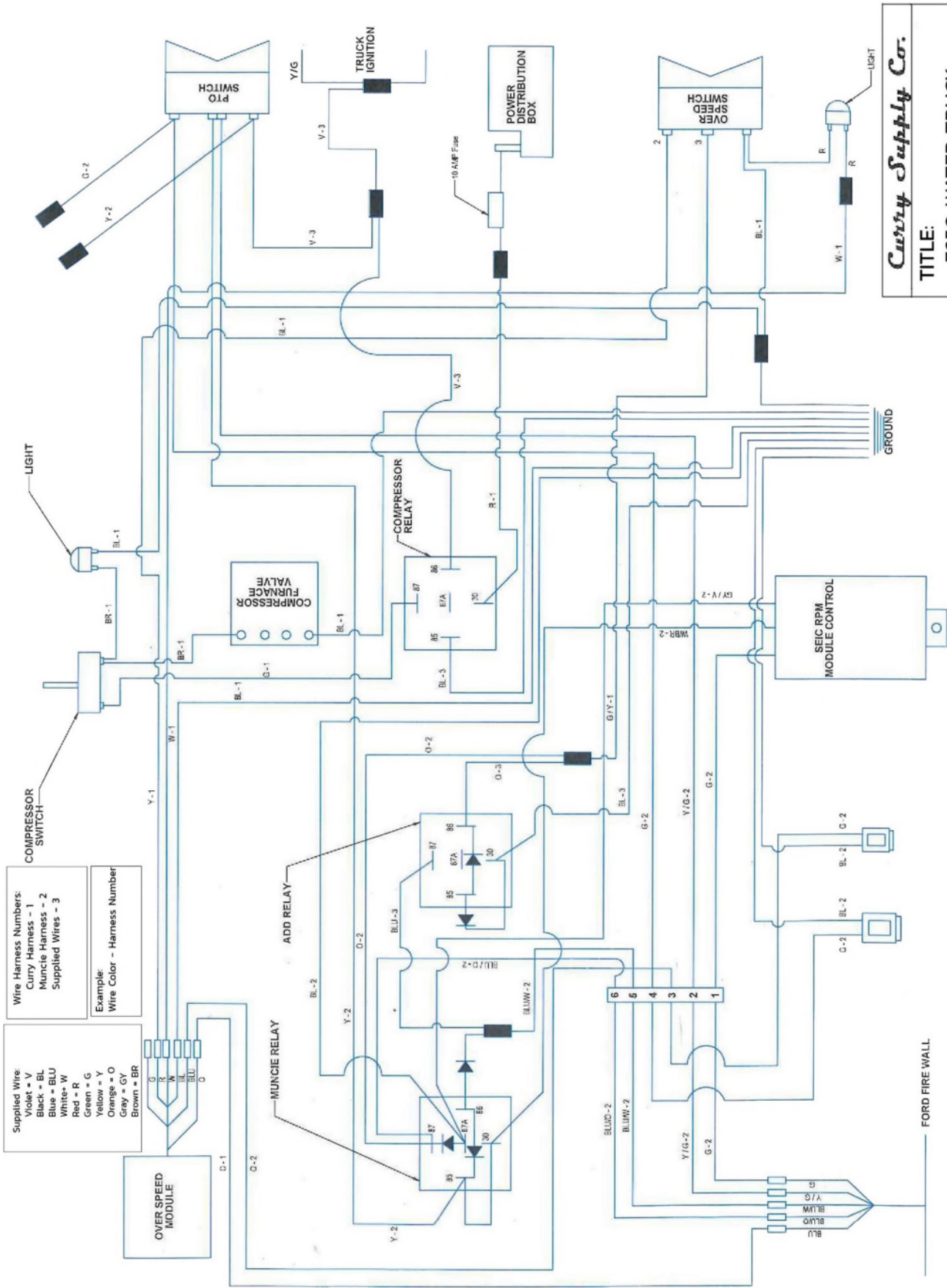

Curry Supply Co.
TITLE:
F650 WATER TRUCK
WIRING DIAGRAM

Supplied Wire:
 Violet = V
 Black = BL
 Blue = BLU
 White = W
 Red = R
 Green = G
 Yellow = Y
 Orange = O
 Gray = GT
 Brown = BR

Wire Harness Numbers:
 Curry Harness - 1
 Muncie Harness - 2
 Supplied Wires - 3

Example:
 Wire Color - Harness Number

FR6Q-F1209-D3*X Wire Harness Schematic - (34T41671) 2016 & Earlier F-250-F-550 Super Duty Diesel Stationary F-650/750 (2012-2015 with SEIC Controls) OR Mobile Mode Application

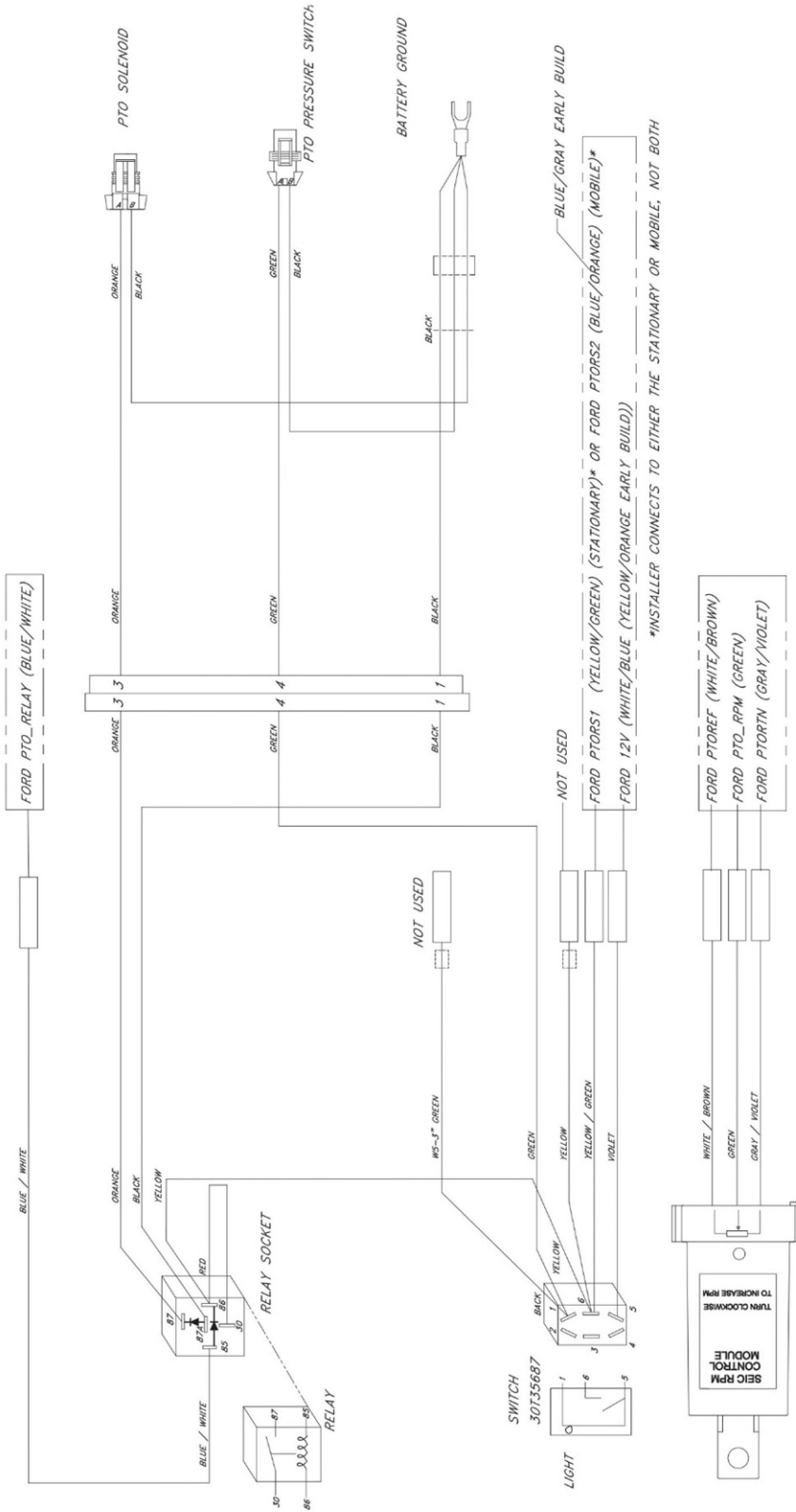

FR6Q1209D3*X WIRE HARNESS #34T41671 Wire Color, Pin#, Circuit # Reference (Mobile OR Stationary Mode)

Harness Wire Color	Circuit Intent	Ford Wire Tag	PCM Pin	Circuit No.	Ford Wire Color	
					Stationary Mode	Mobile Mode
Blue/White	Output	PTO_RELAY	C-11	CE326	Blue/White	Blue/White
Yellow/Green	Input (VPWR)	PTORS1/ PTORS2	C-06	CE912	Yellow/Green	Blue/Orange (Blue/Gray-Early Build)
White/Brown	Reference Voltage	PTOREF	C-55	LE434	White/Brown	White/Brown
Green	Input (Resistor)	PTO_RPM	C-08	CE914	Green	Green
Gray/ Violet	PCM Ground	PTORTN	C-22	RE327	Gray/Violet	Gray/Violet
Violet	12Vdc Power				White/Blue (Yellow/Orange-Early Build)	White/Blue (Yellow/Orange-Early Build)

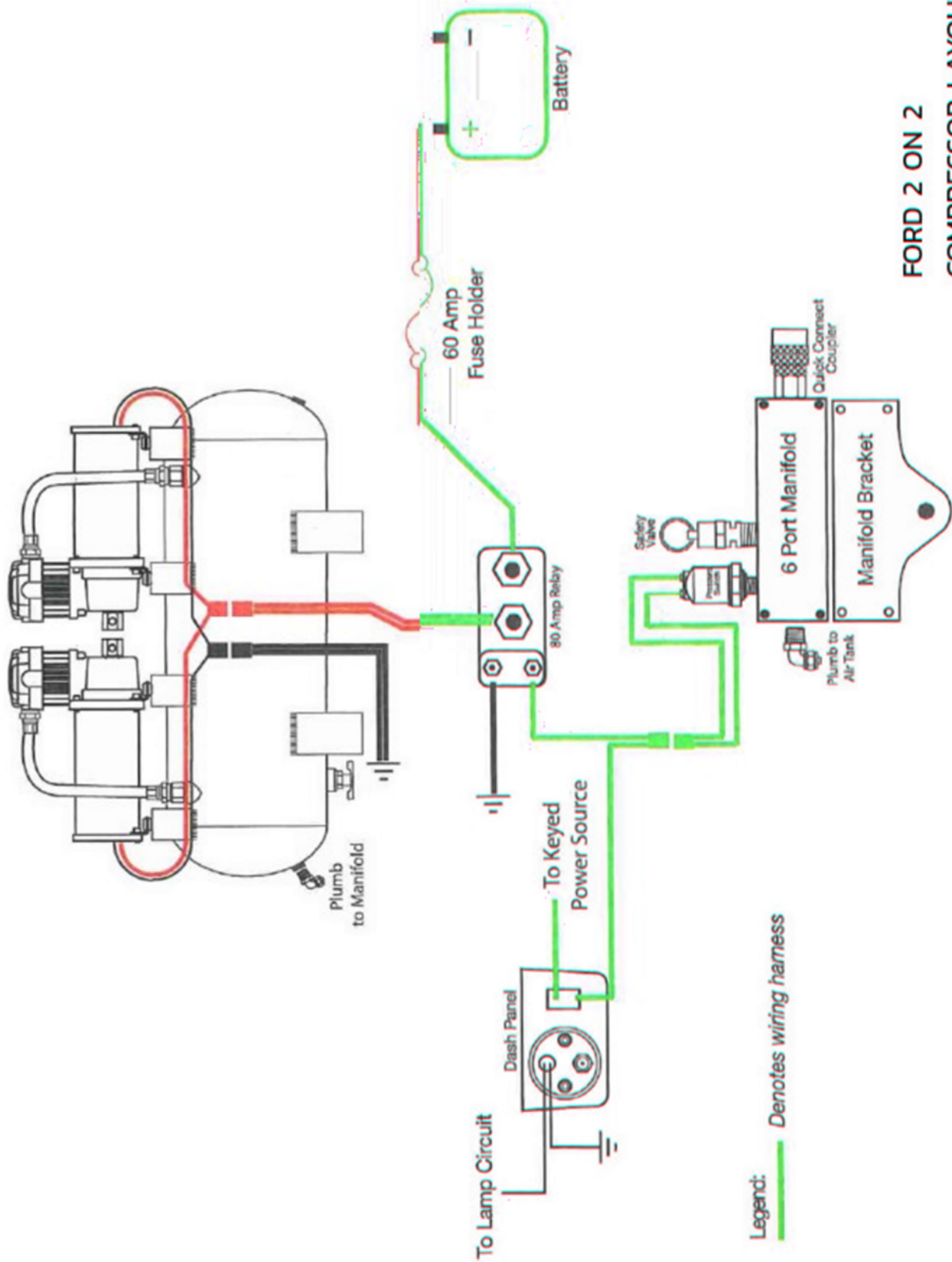

**FORD 2 ON 2
COMPRESSOR LAYOUT**

SECTION 6

Troubleshooting

PROBLEM	POSSIBLE CAUSE	REMEDIES
No water pressure	PTO is not turned on	Turn on PTO to get power to the water pump.
	Creek fill valve left open	Close all creek fill valves to build water pressure.
No power to PTO	Blown fuse	Review the truck's manual for fuse location and replace blown fuse.
	Engine not running	With truck in park, turn on engine ignition.
Spray head not spraying water	Spray head not open	Make sure spray head is open on tower or control dash.
	PTO not turned on	Turn on PTO to get power to water pump.
Water Cannon will not function	Water Cannon Power not turned on	Turn on power by pulling up on water cannon power knob.
	Water Canon toggle switch is in "Closed" position	Move toggle switch to either "Trigger" or "Open" Position.
	Blown fuse	Review the truck's manual for fuse location and replace blown fuse.
Water Cannon will not move, moves intermittently	Debris blocking movement	Check for debris and clear obstruction.
	Monitor wires damaged	Inspect wires for connection or splicing, replace or contact customer service.



For technical help or parts, please have the model number available and call our customer service.

800.345.2829

SECTION 7

Warranty & Proprietary Information

Curry Supply Company warrants products designed and manufactured by Curry Supply Company to be free from defects in material and workmanship under proper use and maintenance. Products must be installed and operated in accordance with Curry Supply's written instructions and capacities. All warranty periods will begin on the in-service date as defined in this document. This warranty shall cover the following Curry Supply Products:

	1 Year	2 Years	Variable
On Road Water / Flatbed / Crash Attenuator / Lube Skid			
Curry Manufactured Components		✓	
Paint Coverage on Curry Manufactured Parts	✓		
Parts	✓		
Repair Labor	✓		
Off Road / Dump / Industrial Carrier / Vacuum / Winch / Railroad			
Tank	✓		
Tank Exterior Paint Coverage	✓		
Parts	✓		
Repair Labor	✓		
Mechanics			
Body (Refer to Manufacture Warranty)			✓
Crane (Refer to Manufacture Warranty))			✓
Paint Coverage (Refer to Manufacture Warranty)			✓
Parts (Refer to Manufacture Warranty)			✓
Repair Labor (Refer to Manufacture Warranty)			✓
Lube			
Body (Refer to Manufacture Warranty)	✓		
Tanks (Refer to Manufacture Warranty)			✓
Parts	✓		
Repair Labor	✓		
Paint Coverage	✓		
Utility Lift			
Body (Refer to Manufacture Warranty)			✓
Lift (Axion)			✓
Parts	✓		
Repair Labor	✓		
Body Paint Coverage	✓		

Definitions

Curry Supply Manufactured Components/Structures – Includes any structural weldment or load bearing support structure manufactured by Curry Supply Company.

Rust Through on Curry Supply Components/Structures – Rust Through is defined as a hole in the metal caused by corrosion. Excluded is corrosion caused by external caustics, including but not limited to improper cleaning material, road salt and other chemicals left on the structure for extended periods of time.

Paint Coverage on Curry Supply Manufactured Parts – Curry Supply guarantees that exterior paint will not fail in terms of adhesion, blistering or unreasonable loss of color or gloss for a 1-year period. Excluded is damage such as chips, dents, scratches, tank interior coating, and corrosion due to caustic chemicals (e.g. Brine Solution / Leachate) and dirt build-up. Regular cleaning and maintenance of the product to remove external factors is expected to keep this warranty in force.

Vendor Supplied Components/Structures – Products purchased by Curry Supply from outside vendors. These items shall be covered by the warranty offered by the respective manufacturer only. Curry Supply does not obligate itself to any such warranty.

Warranty Process

Curry Supply's obligation under this warranty is limited to, and the sole remedy for any such defect shall be, the repair and/or replacement (at Curry Supply's option) of the unaltered part and/or component in question. Curry Supply after-sales service personnel must be notified by telephone, email, or letter of any warranty applicable damage within fourteen (14) days of its occurrence. If possible, Curry Supply will ship the replacement part within 24-hours of notification by the most economical, yet expedient, means possible. Expedited freight delivery will be at the expense of the owner.

Warranty claims must be submitted and shall be processed in accordance with Curry Supply's established warranty claim procedure. Curry Supply after-sales service personnel must be contacted prior to any warranty claim. A return materials authorization (RMA) may be issued to the claiming party prior to the return of warranty parts. Parts returned without prior authorization will not be recognized for warranty consideration. All damaged parts must be returned to Curry Supply freight prepaid; freight collect returns will be refused. Freight reimbursement of returned parts will be considered as part of the warranty claim.

Warranty Repair

Warranty service will be performed by any Curry Supply factory, Curry Supply mobile technician, Curry Supply authorized service partner, or by the affected owner. At the time of requesting warranty service, Curry Supply after-sales service personnel will verify date of delivery of the product. The owner shall be obligated to pay for any overtime labor requested of the servicing company by the owner, any field service call charges, and any towing and/or transportation charges associated with moving the equipment to the designated repair/service provider.

All obligations of Curry Supply and its service providers shall be voided if someone other than an authorized Curry Supply provider performs other than routine maintenance service without prior written or verbal approval from Curry Supply. In the case repair work is performed on a Curry Supply-manufactured product, original Curry Supply parts must be used to keep the warranty in force. The warranty may also be voided if the product is modified or altered in any way not approved, in writing, by Curry Supply.

Warranty Limitations/Responsibilities

This warranty covers only defective material and workmanship. It does not cover depreciation or damage caused by normal wear and tear, accident, mishap, untrained operators, or improper or unintended use. The owner has the obligation of performing routine care and maintenance duties as stated in Curry Supply's written instructions, recommendations, and specifications. Any damage resulting from owner/operator failure to perform such duties shall void the coverage of this warranty. The owner will pay the cost of labor and supplies associated with routine maintenance.

The only remedies the owner has in connection with the breach or performance of any warranty on the Curry Supply product specified are those set above. In no event will Curry Supply, or any company affiliated with Curry Supply, be liable for business interruptions, costs of delay, or for any special, indirect, incidental, or consequential costs or damages. Such costs may include, but are not limited to, loss of time, loss of revenue, loss of use, wages, salaries, commissions, lodging, meals, towing, hydraulic fluid, or any other incidental cost.

All products purchased by Curry Supply from outside vendors shall be covered by the warranty offered by that respective manufacturer only. Curry Supply does not participate in, or obligate itself to, any such warranty.

Curry Supply reserves the right to make changes in design or improvement upon its products without imposing upon itself the same upon its products theretofore manufactured.

9-Oct-24

This warranty will apply to all Curry Supply manufactured components/structures and upfit workmanship shipped from Curry Supply's factory. The warranty is for the use of the original owner only and is not transferable without prior written permission from Curry Supply.

Curry Supply After-Sales Contact Information:

Phone: (800) 345-2829

Email: service@currysupply.com

Mailing Address: 1477 DeGol Industrial Drive, Hollidaysburg, PA 16648

THIS WARRANTY IS EXPRESSLY IN LIEU OF ANY OTHER WARRANTIES, EXPRESS OR IMPLIED, INCLUDING ANY WARRANTY OF MERCHANTABILITY OR FITNESS FOR A PARTICULAR PURPOSE. REMEDIES UNDER THIS WARRANTY ARE LIMITED TO THE PROVISION OF MATERIAL AND SERVICES, AS SPECIFIED HEREIN. CURRY SUPPLY COMPANY, IS NOT RESPONSIBLE FOR INCIDENTAL OR CONSEQUENTIAL DAMAGES.

EXCEPT AS STATED, THERE IS NO WARRANTY, EXPRESS OR IMPLIED, IN CONNECTION WITH THE DESIGN, MANUFACTURE, SALE OR USE OF THE MACHINERY, ACCESSORIES, EQUIPMENT AND PARTS SOLD BY CURRY SUPPLY CO. CURRY SUPPLY COMPANY'S LIABILITY ON ITS WARRANTY SHALL IN NO EVENT EXCEED THE COST OF THE ITEM OF SALE.