

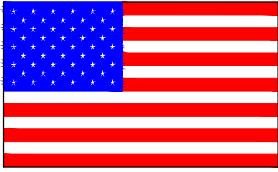

Woodbine, Iowa



Made in America

# OWNER'S / OPERATOR'S MANUAL

- Safety Information
- Warranty Information
- Operator's Instructions
- Maintenance Instructions
- Parts List



**G<sup>2</sup> SERIES**  
**700-2000 LB CAPACITY**

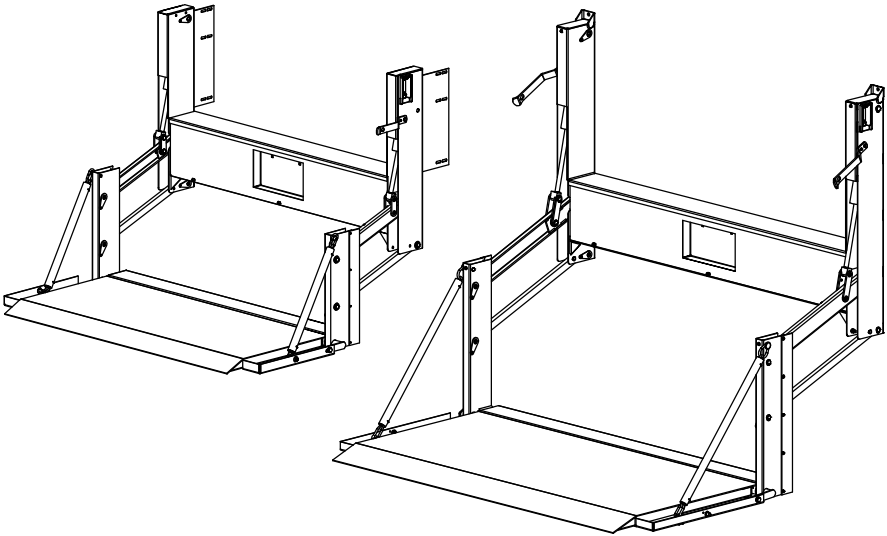

Before installing or using this liftgate, please observe the Vehicle Loading Limitations. These loading limitations are outlined in the Vehicle Owner's Manual and the Safety Compliance Certification Label located on the driver's door pillar. CAUTION



PLEASE KEEP IN VEHICLE



# TABLE OF CONTENTS



<b><u>Introduction</u></b>	<b>Page #</b>
To the Owner\Operator-----	3
<b><u>Safety Decals</u></b>	
Location and Descriptions-----	4 - 6
Decal Replacement-----	6
<b><u>Operator's Instructions</u></b>	
G <sup>2</sup> Series Terms and Method of Operation-----	7
Operator's Instructions-----	8
Latch Adjustment-----	9 - 10
Lift-N-Dump as a Dump Body-----	11
Platform Drop Away Feature (Excludes 2000# TP Platform)-----	12 - 13
Spare Tire Access (pickup liftgate only)-----	14
<b><u>Electrical Wiring Diagrams</u></b>	
Standard Fixed Control-----	15
Optional Pendant Control-----	16
Ladder Logic/Wiring Diagram-----	17
<b><u>Maintenance and Service</u></b> -----	18
<b><u>Troubleshooting</u></b> -----	19
<b><u>Warranty</u></b>	
Standard Warranty-----	20
Warranty Claims Handling Procedure-----	20 - 21
<b><u>Repair Parts List</u></b>	
Repair Parts Drawing-----	22 - 23
Repair Parts List-----	24
<b><u>Hydraulic Fluid Notice</u></b> -----	25
<b><u>Service Records</u></b> -----	27
<b><u>Contact Information</u></b> -----	28

Note: This manual applies to both 42" and 50" travel lifts. If an instruction or illustration is unique to either the 42" or 50" lift it will be so indicated. If it is not so indicated, an instruction or illustration then applies to both the 42" and 50" travel lifts.

Read this manual completely before using your gate. Operate and maintain your gate safely as outlined in this manual. Be sure you read and understand all operating, safety, maintenance and service information. Should you need repair or service information, contact Tommy Gate or an authorized distributor for assistance.



This is the safety alert symbol. It is used to alert you to potential personal injury hazards. Obey all safety messages that follow this symbol to avoid possible injury or death.



**DANGER** indicates an imminently hazardous situation which, if not avoided, will result in death or serious injury.



**WARNING** indicates a potentially hazardous situation which, if not avoided, could result in death or serious injury.



**CAUTION** indicates a potentially hazardous situation which, if not avoided, may result in minor or moderate injury.



**CAUTION** indicates a potentially hazardous situation which, if not avoided, may result in property damage.

Safety is a primary concern in the design and manufacture of our products. Unfortunately, our efforts to provide safe equipment can be wiped out by a single careless act of an operator.

Accident prevention and safety are dependent upon the awareness, concern, prudence and proper training of the personnel who operate, transport, maintain and store this equipment. It is your responsibility to use good judgment in the operation of this equipment.

It has been said that "**the best safety device is an informed, careful operator.**" We ask you to be that kind of operator.

Locate and read all decals prior to operating gate  
**REPLACE IF MISSING OR NOT READABLE**

**TOMMY GATE®**

**DO'S**

- \* DO CENTER YOUR LOAD ON PLATFORM.
- \* DO CLOSE AND LOCK LIFT IN CLOSED POSITION WHEN NOT IN USE OR UNATTENDED.
- \* DO STAND TO THE SIDE OF LIFTGATE WHILE IT IS IN OPERATION.
- \* DO READ MAINTENANCE AND SERVICE INFORMATION.
- \* DO READ OPERATOR'S INSTRUCTIONS.
- \* DO FREQUENTLY CHECK CABLES CHAINS, AND OTHER COMPONENTS FOR WEAR OR DAMAGE AND REPAIR AS NECESSARY WITH PARTS PROVIDED BY THE ORIGINAL EQUIPMENT MANUFACTURER.
- \* DO CHECK ALL SAFETY DEVICES FOR PROPER OPERATION .

**DO NOT'S**

- \* DO NOT RIDE OR PERMIT ANYONE TO RIDE ON LIFT. THE LIFT IS NOT A PERSONNEL OR WHEELCHAIR LIFT.
- \* DO NOT MAKE ANY MODIFICATIONS TO THE LIFT OR ITS SAFETY FEATURES.
- \* DO NOT ALLOW USE OF LIFT BY A PERSON WHO HAS NOT HAD PROPER TRAINING IN ITS OPERATION.
- \* DO NOT TRY TO LIFT OR LOWER MORE THAN THE RATED CAPACITY OF THE LIFT.
- \* DO NOT ADD TO OR REMOVE PARTS OF LIFT AS IT WILL VOID YOUR WARRANTY.
- \* DO NOT MOVE VEHICLE UNLESS GATE IS IN LATCHED POSITION.
- \* DO NOT SHOW CHILDREN OR UNAUTHORIZED PERSONNEL HOW TO OPERATE LIFT.
- \* DO NOT LEAVE PLATFORM OPEN, OR UNLATCHED WHEN LIFT IS NOT IN USE OR UNATTENDED. NEVER LEAVE PLATFORM DOWN TO BE USED AS A STEP.

ALL REPAIRS OR REINSTALLATIONS OF TOMMY GATE LIFTS SHOULD BE PERFORMED BY AN AUTHORIZED DISTRIBUTOR THAT IS FAMILIAR WITH ITS OPERATION AND SAFETY FEATURES. ALL REPLACEMENT PARTS MUST BE OF ORIGINAL QUALITY, AND ALL SAFETY AND OPERATIONAL DECALS MUST BE ATTACHED AND LEGIBLE

9561

Decal No. 1

Place in cab in a highly visible area.

⚠ WARNING

Keep one hand on the platform when opening and closing.

Platform opening and closing forces/weights will vary if your vehicle is on an incline.

Stand clear of all moving parts when opening, raising or lowering platform.

Never leave the platform down to be used as a step.

Do not add any extension to original platform.

9523

Decal No. 2

Located on the outside right-hand corner of the platform.

⚠ WARNING

Read operator's manual before operating equipment.

Do not modify lift or its safety features.

Use only Tommy Gate service parts installed by an authorized distributor.

If additional assistance is needed, call Tommy Gate at 712-847-8000

Do not exceed the rated lift capacity-

9524

Decal No. 3

Located next to the control shield.

⚠ DANGER

Keep away from moving parts

9555

Decal No. 4

Located on the side of uprights

Rated Lift Capacity

XXX lb or XXX kg

750 lbs. 9453 1500 lbs. 9481  
1000 lbs. 9477 1600 lbs. 9479  
700 lbs. 15885 1300 lbs. 9478 2000 lbs. 9480

Decal No. 5

Located next to the control shield.

**⚠ WARNING**

Do not ride the platform.

This lift is not designed as a wheelchair or personnel lift.

---

Center Load

Center load on platform side to side and front to back.

Never allow children or any untrained person to operate the lift.

Do not show children or others how to operate the lift.

When the lift is not in use or unattended, the platform should be closed and latched with control secured. 9522

Decal No. 6

Located on left-hand upright inside the frame.  
(Or on right hand side of lift and dump models.)

The original  
**TOMMY GATE**  
hydraulic lift

Part Number:

Serial Number:

Decal No. 7

Located on the inside of the main frame, positioned over the top of the pump & motor unit.  
Located next to the control shield.

**⚠ CAUTION**

Spring under high tension

9540

Decal No. 8

Located on the upright next to the torsion spring and safety holder on models with torsion assist spring.

**⚠ DANGER**

Before removing box cover do the following.

- 1) Lower platform to ground or close and latch.
- 2) Disconnect positive battery cable(s).

9556

Decal No. 9

Located on box cover of gate.

**⚠ WARNING**

Liftgate is not to be used as a scale.

Liftgate may lift more than its rated capacity.

Be aware of how much is being lifted and never exceed the rated capacity of the liftgate.

Be aware of how much is being hauled and never exceed the rated capacity of the vehicle. 9044

Decal No. 10

Located next to the control shield.

<b>CAUTION</b>	
<p><b>USING LIFT-N-DUMP AS A DUMP BODY TAILGATE:</b></p> <p>The liftgate must be fully raised with the platform folded and secured with both lynch pins to the liftgate frame.</p> <p>Do not unpin or unlatch insert with hoist raised.</p> <p>Stand to the side, not behind or under the liftgate when unpinning or unlatching the insert latch lever. The dump platform will swing out.</p> <p>Keep hands, feet, and limbs clear of a swinging insert.</p> <p>Close, latch, and pin insert latch lever when the dump body hoist is in the completely lowered position only.</p>	

9142

Decal No. 11  
Placed on every lift and dump model.  
Located on the outside bottom left-hand corner of the platform.

<b>CAUTION</b>	
<p><b>USING LIFT-N-DUMP AS A LIFTGATE:</b></p> <p>Never use Lift-N-Dump as a liftgate when the dump body hoist is raised.</p> <p>Never unfold the platform, unless both insert latch pins are fully engaged in the platform frame, and the latch lever is latched and pinned.</p> <p>Hold down clamps must be used to secure dump body to truck frame when a single action body hoist is used.</p> <p>Stand to the side, not behind or under the liftgate, when unfolding the platform.</p>	

9141

Decal No. 12  
Placed on every lift and dump model.  
Located on the outside top right-hand corner of the platform.

<b>WARNING</b>	
<p>STAND CLEAR WHEN RELEASING LATCH AND DURING DUMP OPERATION</p>	

9140

Decal No. 14  
Placed on every lift and dump model.  
Located on the outside top center of the platform

9140

Decal No. 13  
Placed on every lift and dump model.  
Located on the outside bottom left-hand corner of the platform.

<p><b>WARNING: Cancer and Reproductive Harm-</b> <a href="http://www.P65Warnings.ca.gov">www.P65Warnings.ca.gov</a></p> <p style="font-size: x-small;">15721</p>
--

Decal No. 15  
Located on the side of the control.

## DECAL REPLACEMENT

**NOTE: When ordering Decals, please have Decal Numbers available.**

To replace decal, clear area of grease and dirt with non-flammable solvent and soap and water. Allow to dry. To apply decal, peel off 1/2 of back. Hold decal squarely and apply to cleaned surface. Peel off remaining back and smooth in place. Gently rub decal with a damp rag or sponge to smooth out bubbles. (The decal has a pressure-sensitive adhesive on the back.)

If the liftgate **is** going to be painted, you need to mask the decals before painting. Remove the mask **after** painting so the decals can be read clearly.



## G<sup>2</sup> SERIES TERMS AND METHOD OF OPERATION



Your Tommy Gate is connected to your vehicle battery. The vehicle battery powers a motor, coupled to a hydraulic pump. This motor and pump combination is called a power unit. Flow from the pump retracts the two cylinders attached to the upper arm assembly that lift the gate platform.

**!Warning:** Liftgate is not to be used as a scale. Liftgate may lift more than its rated capacity. Be aware of how much is being lifted and never exceed the rated capacity of the liftgate. Be aware of how much is being hauled and never exceed the rated capacity of the vehicle.

The gate platform is lowered by gravity after an electric "lower" solenoid valve is activated and opened at the power unit.

Tommy Gate's control incorporates a "Low Voltage" warning feature. A "Low Voltage" condition exists when the "Power On" button is armed and 7 Volts or less is present at the power unit. This "Low Voltage" feature is designed to warn the operator that there is a low voltage condition and that it should be corrected as soon as possible. The amber "Power On" LED will blink to warn the operator of this condition. When this light is blinking, it will not prevent the control from functioning to raise or lower the gate. In a "Low Voltage" situation, whether the gate actually raises or lowers depends on how low the voltage is.

**Caution:**

Continuing to operate the the liftgate in the "Low Voltage" condition may result in failure of electrical components in the power unit.

The low voltage condition may be caused by a weak battery, loose or corroded connections, improper ground, or bad electrical cables. This condition may be corrected by just starting the vehicle or replacing the battery.

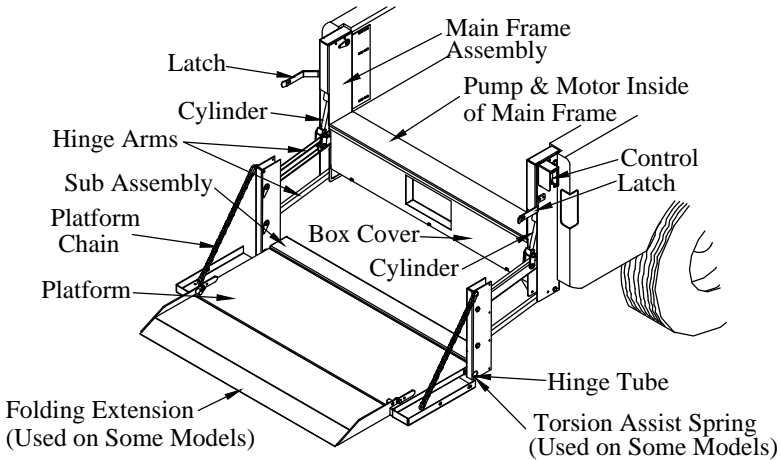

**!Caution:**

**Never leave the truck with the platform on the ground, partially raised, or open. Never show children or unauthorized personnel how to operate the gate.**

To prevent children or unauthorized personnel from operating the lift, be sure the gate is in the stored position and both the driver's side and passenger's side latches are secured. Make sure the passenger's side latch padlock is installed and the control is deactivated before leaving the truck unattended.

**!Warning:** The Tommy Gate is an industrial product for material handling only and is not to be used as a personnel or wheelchair lift. Do not ride on the platform and always stand clear of the platform when opening, raising or lowering.

Step 1. To open the platform, go to the driver's side of the Tommy Gate, push the latch to the side, off the platform pin, and rotate the latch down. Proceed to the passenger's side of the Tommy Gate and remove the latch padlock. Push the passenger's side latch to the side, off the platform pin with one hand while holding the top of the platform with your other hand. Pull the platform open and step away from the platform as it opens.

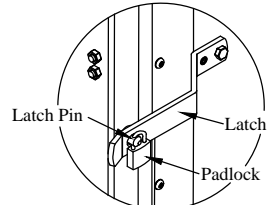

**Figure 1**

**!Caution:**

**Never use** Lift-N-Dump as a liftgate when the dump body hoist is raised.

Hold down clamps **must be used** to secure dump body to truck frame when a single action body hoist is used.

**Never unfold** the platform, unless both insert latch pins are fully engaged in the platform frame, and the latch lever is latched and pinned.

To open the Lift-N-Dump platform, open the hasps and remove the driver side lynch pin. Remove the padlock on passenger side.

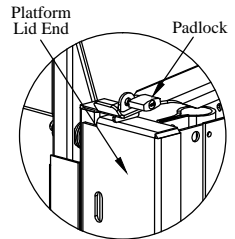
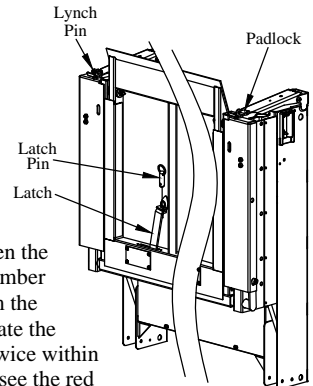

**Figure 2-LND**

Step 2. If the gate is on an application with swing out doors, you can open them at this time.

Step 3. Be sure to stand clear of the platform and all moving parts when using the lift.

Step 4. To turn the control power on, press the "POWER ON" hidden switch once, marked with white rings or circles (located between the Tommy Gate logo and the toggle switch). You should see the amber LED "POWER ON" light when the control is armed. To disarm the control press the "POWER ON" hidden switch again. To activate the control, press the "LIFTGATE ACTIVATED" hidden switch twice within one second (located under the Tommy Gate logo). You should see the red "LIFTGATE ACTIVATED" light when the control is activated. To lower the platform, push the toggle switch down. To raise the platform, push the toggle switch up. When you remove pressure from the toggle switch, the operation will stop. After you have activated the control by pressing the "LIFTGATE ACTIVATED" hidden switch twice within one second (located under the Tommy Gate logo), you have approximately 90 seconds to use the gate. If the gate is not used for approximately 90 seconds, the "LIFTGATE ACTIVATED" timer deactivates the control. If the gate is used during the 90 seconds, the "LIFTGATE ACTIVATED" timer automatically resets for an additional 90 seconds. To reactivate the timer, press the "LIFTGATE ACTIVATED" hidden button twice within one second.



**Figure 3**

Step 5. After the platform is raised to the level of the vehicle's floor and the load is removed, close the platform and folding extension (if so equipped). The latch on the passenger's side will secure itself. Install the latch padlock on the passenger's side latch. Go to the driver's side and secure the latch.

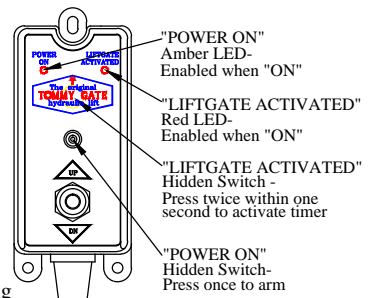

**Figure 4**



Make sure the liftgate is in the fully raised position.

Disconnect the #4 power cable from the positive side of the battery or manually trip the circuit breaker. Remove the latch padlock from the passenger's side of the platform.

Unlatch the driver's side latch and then the passenger's side latch. Unfold the liftgate platform.

Remove the Phillips head screws that hold the upright caps in place, then remove both upright caps (Figures 5 & 6).

Remove the Phillips head screws that hold the control in place, then remove the control.

## Inside of the Uprights

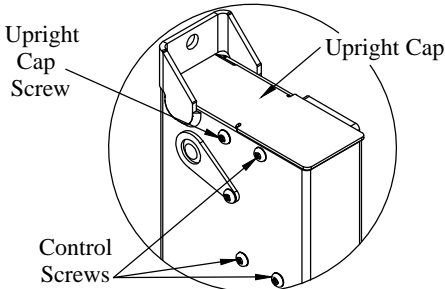

**Figure 5.** Remove the upright cap and control screws.

## Outside of the Uprights

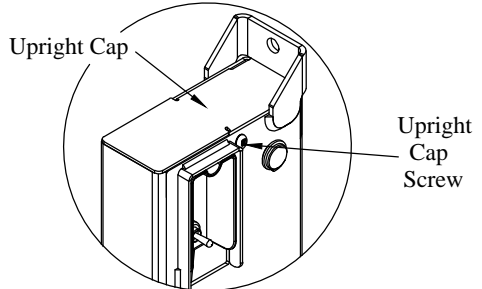
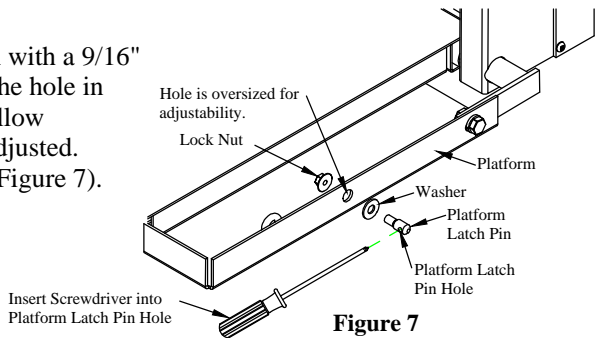

**Figure 6.** Remove the upright cap screw.

Check the spring tension on the driver's side and passenger's side latch springs as shown (Page 10, Figures 8 & 9). The driver's side swing away latch spring should measure 1" tall. Tighten or loosen if necessary. The passenger's side fixed latch spring should measure 7/8" tall. Tighten or loosen if necessary.

Loosen the platform latch pin with a 9/16" wrench and a screwdriver. The hole in the platform is oversized to allow the platform latch pin to be adjusted. See exploded view drawing (Figure 7).

Close and latch the platform.



**Figure 7**

Center the platform latch pin vertically in the latch hole. Push the platform latch pin toward the front of the truck so there is a 1/8" gap (Page 10, Figures 10 & 11).

Tighten the platform latch pin with a 9/16" wrench and a screwdriver.

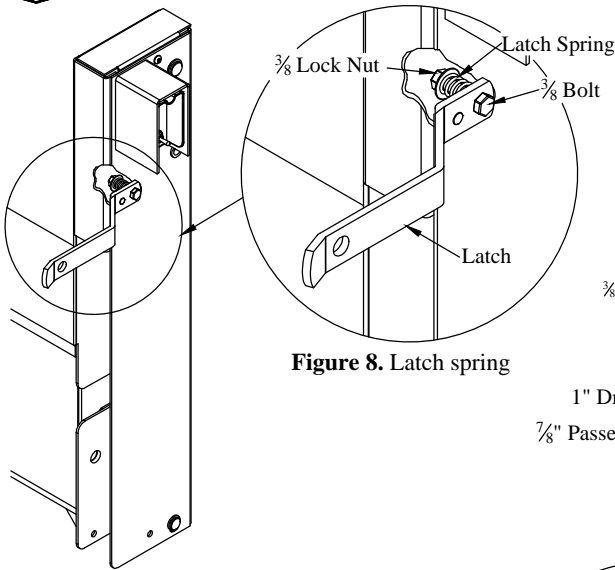

**Figure 8.** Latch spring

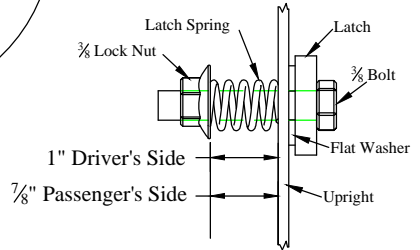

**Figure 9.** Latch spring

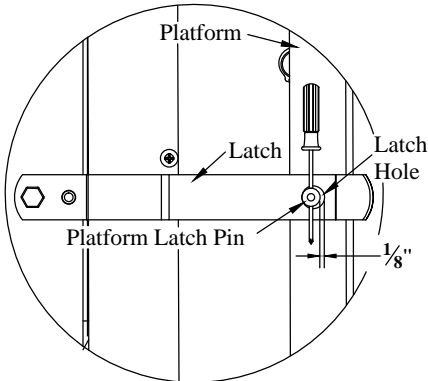

**Figure 10.** Latch pin adjustment  
42 inch travel lift.

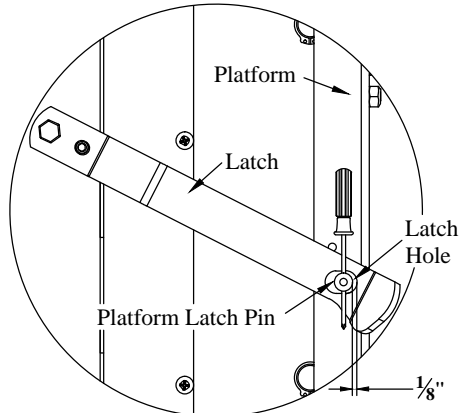
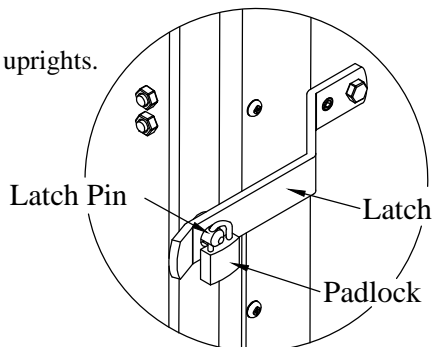

**Figure 11.** Latch pin adjustment  
50 inch travel lift.

Reinstall the control and upright caps on the uprights.

Reconnect the liftgate's main power cable to the positive side of the battery or re-engage the circuit breaker.

Install the latch padlock on the passenger's side of the platform (Figure 12).



**Figure 12.** Latch padlock

**! Caution:**

**Never show children or unauthorized personnel how to operate the gate.**

To prevent children or unauthorized personnel from operating the gate before leaving the truck unattended be sure:

- the gate is in the stored position
- both the driver's side and passenger's side lynch pins are installed
- the insert latch handle is latched and pinned
- the control is deactivated.

Using the dump through feature.

Step 1. The liftgate **must** be fully **raised** with the platform **folded** and **secured** with both lynch pins installed.

Step 2. The dump body **must be lowered** completely to help relieve the pressure on the insert.

**! Caution:**

Never remove the latch pin from the insert latch lever with the hoist raised.

Step 3. **Remove** the latch pin from the insert latch lever. (see Detail B)

**! Caution:**

Never unlatch the insert with the hoist raised.

Step 4. **Stand** to the side, not behind or under the liftgate.

**Unlatch** the insert by pulling the insert latch lever to the side. (see Detail B) The insert will swing out.

**! WARNING**

**Keep hands, feet, limbs and body clear of a swinging insert.**

Closing and latching the insert.

Step 1. The dump body **must be lowered** completely.

Step 2. **Push** on the bottom of the insert to close.

Step 3. **Move** the insert latch lever to the latch position. (see Detail B)

Step 4. **Install** the latch pin in the insert latch lever.

Adjusting the latches. (Figure 14)

Step 1. **Close** and **latch** the platform.

Step 2. **Loosen** the bolts.

Step 3. **Center** the tongue over the latch eye.

Step 4. **Tighten** the bolts.

Step 5. **Repeat** on other side.

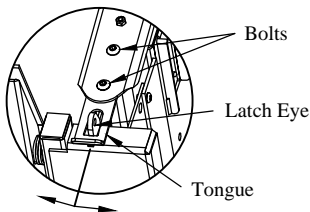

**Figure 14**

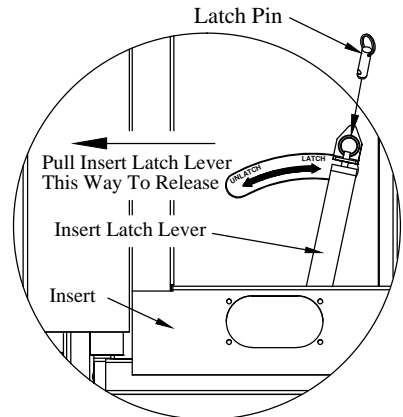
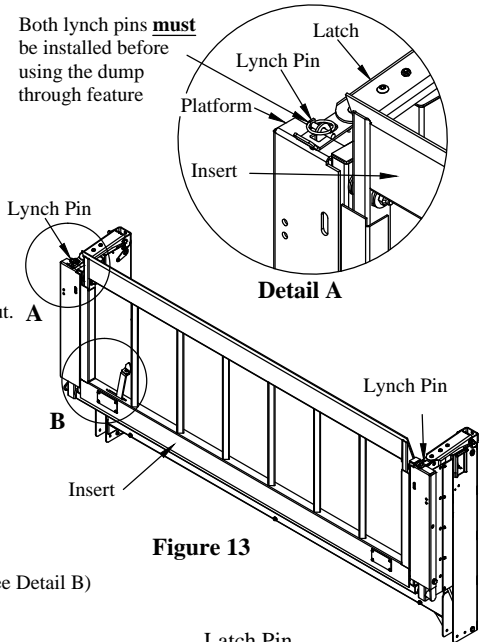

**Detail B**

## PLATFORM DROP AWAY FEATURE

Not available for 2000# Treadplate Platforms

### Installing platform drop away pin (Figure 15).

1. **Insert** the platform drop away pin through the existing 3/8" hole in the upright back.
2. **Fasten** the pin to the upright using the supplied 3/8" nut.

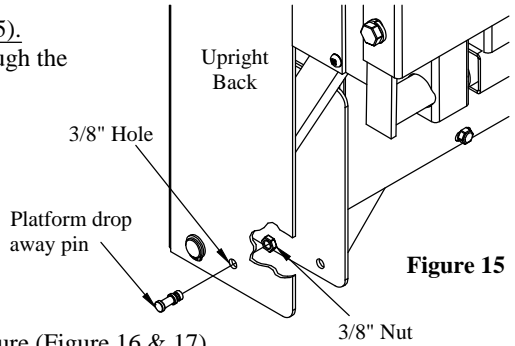

Figure 15

### Preparing chain for platform drop away feature (Figure 16 & 17).

1. **Position** the platform and platform chain as shown in Figure 17.
2. **Unhook** the platform by rotating it over the flat side of the pin.

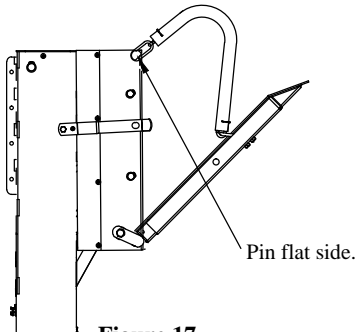

Figure 17

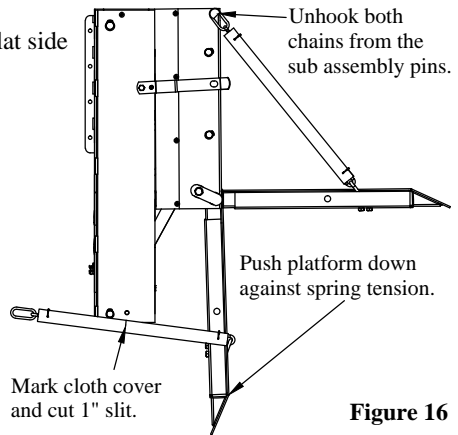

Figure 16

**!Caution - The platform may spring back with great force if released under pressure.**

3. **Push** the platform down and **pull** driver side chain toward the drop away pin on the upright.
4. **Mark** the position of the cloth cover that is next to the drop away pin.
5. **Slowly release** the platform allowing the spring tension to lessen.
6. **Cut** a 1" slit in the cloth cover.

Using platform drop away feature (Figure 18).

1. **Unhook** both platform chains from the sub-assembly pins.
2. **Pull** chain link through slit cut in driver side chain cover.

!Caution - The platform may spring back with great force if released under pressure.

3. **Push** the platform down and **hook** exposed link over drop away pin on the upright.

Caution - If equipped the platform flipper may fall open and contact the ground if the ball locks on the platform are not in good working order.

Hook exposed chain link to drop away pin on driver side upright.

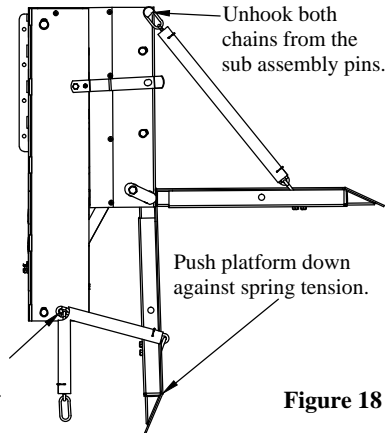

**Figure 18**

Disabling platform drop away feature.

1. **Reverse** order of above instructions.

Accessing the Spare Tire

There are holes in the back of the liftgate which provide access to the factory spare tire crank on some pickup liftgates. The following will help you locate the spare tire access hole for your application.

1. **Remove** the box cover by removing the 5/16" hex head nuts (Figure 19).
2. **Locate** the access hole for your application using Figure 20 and Table 1.
3. **Insert** the vehicle spare tire crank rod through the access hole

The spare tire crank rod is inserted at an angle, toward the center of the truck.

4. **Rotate** the vehicle spare tire crank rod to raise or lower the spare tire.
5. **Reinstall** the box cover and 5/16" hex head nuts when finished.

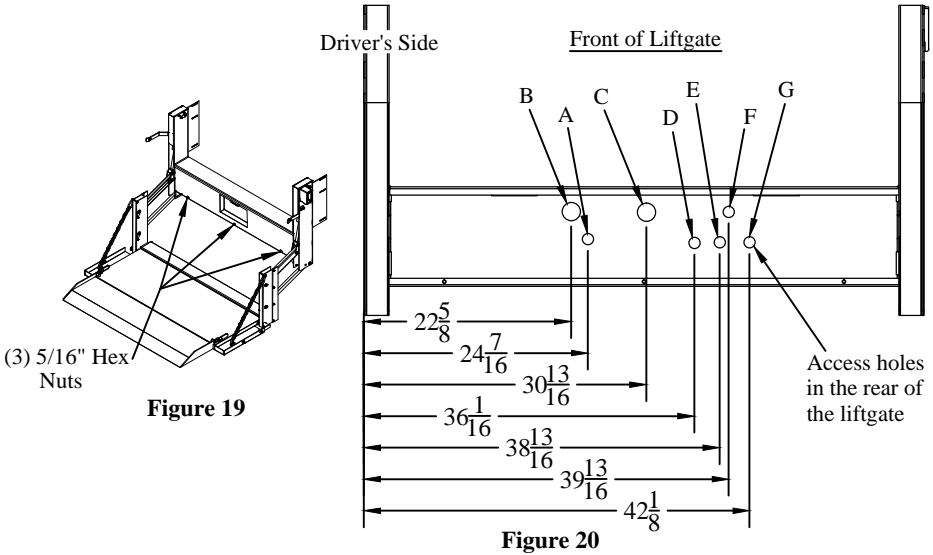

**Table 1**

Pickup Application	Access Hole	Pickup Application	Access Hole
F-150 & F-250 LD (1997-2003)	A	Super Duty Series (2008-Present)	D
Super Duty Series (1999-2007)	A	Ford Ranger (2019-Present)	D
Nissan Titan (2004-Present)	B	Chevy/GMC Long Box (2007-2019) Except 2019 1500 Long Box	E
Toyota Tundra (2007-Present)	C	Chevy/GMC 1500 "LD" or "Limited" Long Box (2019)	E
Chevy/GMC Short Box (2007-2019)	D	Dodge/Ram (2003-2018)	F
Chevy/GMC 1500 Long Box (2019) Except "LD" or "Limited"	D	Ram 1500 "Classic" (2019-2022)	F
Chevy/GMC 1500-3500 (2020-Present)	D	Ram 2500/3500 (2019-Present)	F
Chevy Colorado/GMC Canyon (2015-Present)	D	Ram 1500 (2019-Present) Except "Classic"	G
F-150 (2004-Present)	D		

# ELECTRICAL WIRING DIAGRAM

## Standard Fixed Control



**WELDING NOTE !!! DISCONNECT ALL BATTERY CABLES. ALWAYS DISCONNECT THE GROUND CABLE FIRST. ATTACH THE WELDING GROUND TO THE TRUCK RATHER THAN THE LIFTGATE.**



**!!! PLEASE READ AND FOLLOW ALL DIRECTIONS BEFORE PROCEEDING !!!**



**NOTE !!! IF GATES ARE NOT WIRED IN ACCORDANCE WITH THIS DIAGRAM YOUR WARRANTY WILL BE VOID.**

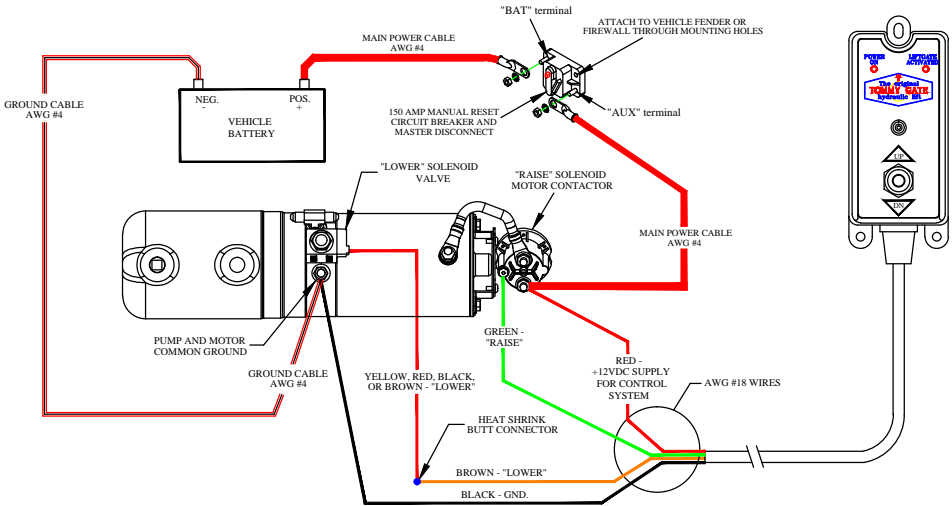

### CONTROL OPERATION

BLINKING AMBER LED INDICATES LOW VOLTAGE CONDITION

"RAISE/LOWER" TOGGLE SWITCH

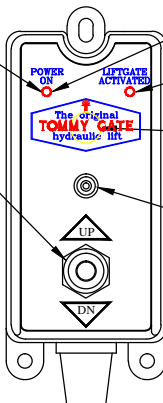

"POWER ON" AMBER LED - ENABLED WHEN "ON"

"LIFTGATE ACTIVATED" RED LED - ENABLED WHEN "ON"

"LIFTGATE ACTIVATED" HIDDEN SWITCH - PRESS TWICE WITHIN ONE SECOND TO ACTIVATE TIMER

"POWER ON" HIDDEN SWITCH - PRESS ONCE TO ARM, PRESS AGAIN TO DISARM

# ELECTRICAL WIRING DIAGRAM

## Optional Pendant Control



**WELDING NOTE !!! DISCONNECT ALL BATTERY CABLES. ALWAYS DISCONNECT THE GROUND CABLE FIRST. ATTACH THE WELDING GROUND TO THE TRUCK RATHER THAN THE LIFTGATE.**



**!!! PLEASE READ AND FOLLOW ALL DIRECTIONS BEFORE PROCEEDING !!!**



**NOTE !!! IF GATES ARE NOT WIRED IN ACCORDANCE WITH THIS DIAGRAM YOUR WARRANTY WILL BE VOID.**

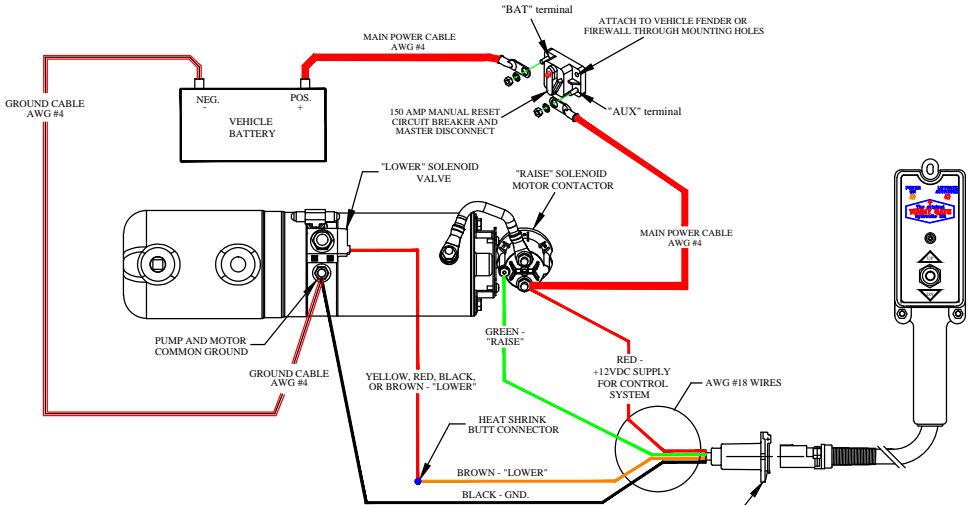

COLE HERSEE SOCKET END	
POSITION	WIRE COLOR
S	BLACK
RT	GREEN
LT	NO WIRE
TM	BROWN
A	NO WIRE
GD	RED

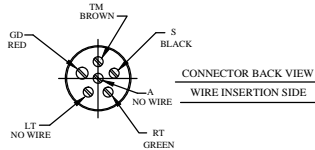

### CONTROL OPERATION

BLINKING AMBER LED INDICATES LOW VOLTAGE CONDITION

"RAISE/LOWER" TOGGLE SWITCH

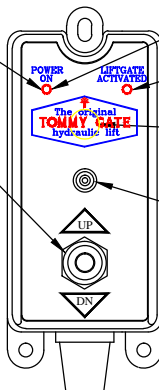

"POWER ON" AMBER LED-ENABLED WHEN "ON"

"LIFTGATE ACTIVATED" RED LED - ENABLED WHEN "ON"

"LIFTGATE ACTIVATED" HIDDEN SWITCH - PRESS TWICE WITHIN ONE SECOND TO ACTIVATE TIMER

"POWER ON" HIDDEN SWITCH - PRESS ONCE TO ARM, PRESS AGAIN TO DISARM



Legend	
	Circuit Breaker
	Contactors - Normally Open Contacts
	Motor
	Solenoid/Contactor - Coil
	Battery Cable
	Wire
	Grounded through motor chassis.
	Eyelet Terminal
	Splice

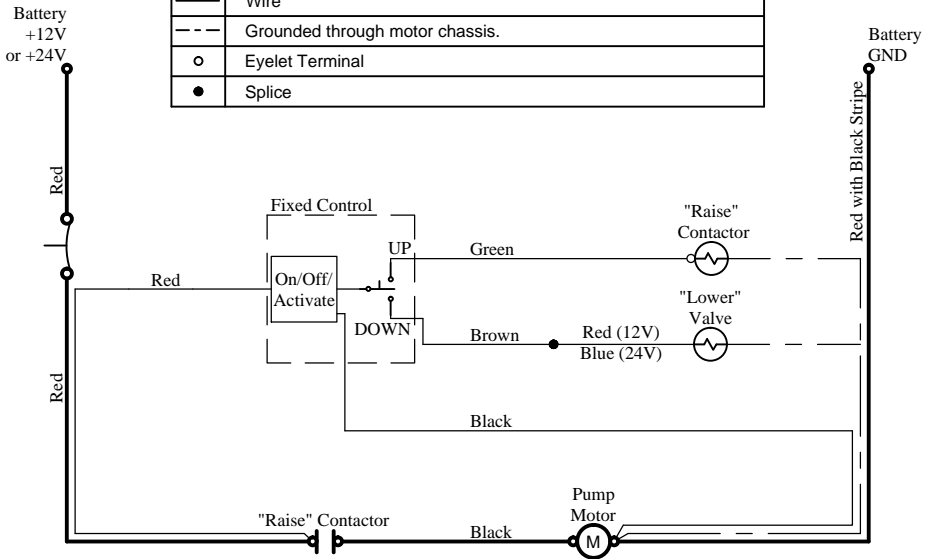

All installations, re-installations, and repairs of Tommy Gates should be performed by a qualified authorized distributor that is familiar with its operation and safety features. All replacement parts must be of original quality, and all safety and operational decals must be attached. No modifications are allowed to a Tommy Gate product unless authorized in writing by the Engineering Department at Tommy Gate.

As is with any mechanical product, a preventive maintenance program needs to be followed in order to keep it in its best operating condition. Please review this information and if you should have any questions, please call (712) 847-8000. Please have your model number and serial number available.

The Tommy Gate needs to be serviced every 120 days or 1500-2000 cycles, whichever comes first.

- (A) Inspect platform chains for any wear. Replace immediately if either is found to be worn.
- (B) Check the oil level in the reservoir. With the liftgate platform at the bottom of its travel, the fluid should be two-thirds full. **BE SURE THE CYLINDERS ARE COMPLETELY EXTENDED.**
- (C) Check for leaks from the cylinders, hoses, and all fittings (replace or repair if found to be leaking).
- (D) Grease all cylinder pivots with an ample amount of grease (every 120 days). Do not grease composite bushings.
- (E) Replace any worn or missing parts before the liftgate is put back into service.
- (F) If needed, adjust platform latches which are designed to hold the liftgate in a properly stored position.
- (G) Check for cracks in all welds (repair if needed).
- (H) Check for wear at all pivot points.
- (I) Check all electrical connections. (clean or repair if needed)
- (J) Replace fuses, if needed. Check electric cables for worn or damaged insulation.
- (K) Replace or clean safety decals, so that they are legible.
- (L) Check for proper operation of the control.

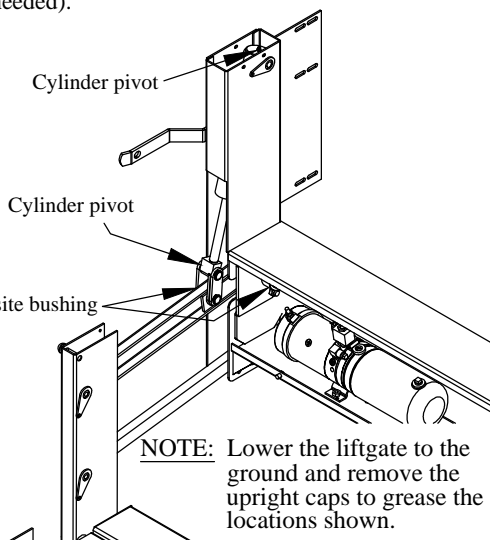

PROBLEM	POSSIBLE CAUSE	REMEDIES	
1.) Lift will not operate -"POWER ON" amber LED light does not come on.	Control not armed properly.	Turn the power on at the control by pressing the "POWER ON" hidden switch, marked with black rings or circles (located between the Tommy Gate logo and the toggle switch).	
	Poor electrical connection.	Check and repair or replace all cables and connections.	
	Polarity is reversed.	Switch positive and negative cables.	
	Circuit breaker tripped or disengaged.	Check for short, then manually engage circuit breaker.	
2.) Lift will not operate- "LIFTGATE ACTIVATED" red LED light does not come on.	Control not activated properly.	Press the "LIFTGATE ACTIVATED" hidden switch twice within one second (located under the Tommy Gate logo). The red "LIFTGATE ACTIVATED" LED light should come on.	
	Faulty control.	Replace control.	
	3.) Blinking amber "POWER ON" LED.	Low voltage condition.	Check and clean or repair all electrical connections. Load test battery, then recharge or replace battery, if required.
		Poor grounds or connections.	Repair, replace, clean as necessary.
4.) Lift will not raise or raises slowly -control working properly.	Power connected or reconnected since last use.	Normal, press bulb/eye once to activate solid "POWER ON" amber LED.	
	Poor electrical connection.	Check power and ground cables and all connections.	
	Battery charge is low.	Recharge or replace battery.	
	Release valve stuck, partially open or dirty.	Raise platform completely and continue to run pump for 5 seconds.	
	Release valve needs replacement.	Contact Tommy Gate or distributor.	
	"Raise" solenoid not working.	Contact Tommy Gate or distributor.	
	Oil level low.	*Check oil and add ISO grade 32 hydraulic oil or equivalent.	
	Vent plug not installed or dirty.	Check vent plug on pump tank. A red shipping plug is installed at the factory. It must be replaced by the metal vented plug.	
5.) Lift settles down slowly with load or no load.	Overloaded liftgate.	Remove some material or weight.	
	Hoses or fittings leaking.	Tighten or replace.	
	Check valve stuck or dirty.	Raise and lower lift several times to flush out valve.	
	Check valve damaged.	Contact Tommy Gate or distributor.	
	Cylinder seals worn or damaged.	Contact Tommy Gate or distributor.	
	"Lower" solenoid sticking partially open.	Contact Tommy Gate or distributor.	
6.) Pump or motor noisy.	Worn pump, motor or coupling.	Contact Tommy Gate or distributor.	
	Oil level low.	*Check oil and add ISO grade 32 hydraulic oil or equivalent.	
7.) Lift lowers very slowly, especially in cold weather.	Hinge arm pins seized to the bushings.	Clean and/or replace arm pins and bushings.	
	Lack of lubrication at cylinder pins and/or upper arm assembly.	Lubricate all zerks.	
	Cylinder pins seized due to lack of lubricant.	Clean and/or replace cylinder pins.	
	8.) Lift will not lower.	Control not armed and activated-No amber "POWER ON" LED or red LIFTGATE ACTIVATED LED light on.	Press the "POWER ON" hidden switch, marked with black rings or circles (located between the Tommy Gate logo and the toggle switch). The amber "POWER ON" LED light should come on. Now press the hidden "LIFTGATE ACTIVATED" switch twice within one second (located under the Tommy Gate logo). The red "LIFTGATE ACTIVATED" LED light should come on.
Poor electrical connections.		Check and clean or repair all electrical connections.	
3 Amp Mini - ATO fuse is blown.		Correct short and then replace fuse.	
Lift stuck or sprung, if control is working properly.		Apply downward load on platform pry away upright sides	
If control is working properly, damaged or non-working "lower" solenoid.		Contact Tommy Gate or distributor.	
Hinge arm or cylinder pins seized.		Lubricate, clean and/or replace pins.	
9.) Cylinders are making noise (squealing).	Oil other than ISO 32 or equivalent has been added to the powerunit.	*Add an oil additive that has been approved by Tommy Gate Co.	

\*Refer to note on page 25.



# WARRANTY GUIDELINES



## **A. STANDARD WARRANTY**

The Tommy Gate Company provides a limited warranty against faulty materials or workmanship. G<sup>2</sup> Series Tommy Gates are warranted for two (2) full years from the date of user purchase against faulty materials or workmanship.

All affected parts must be returned to the factory prepaid - with full credit issued for those found to be defective. Warranty replacement parts will be shipped from the factory prepaid.

Labor charges to install warranty replacement parts shall be paid in accordance with Tommy Gate's estimated repair time guide and a flat hourly rate established by Tommy Gate. **DEVIATION FROM THE WARRANTY TIMES LISTED MUST BE AUTHORIZED BY TOMMY GATE COMPANY IN ADVANCE.**

The warranty does not include damage resulting from improper installation procedures. Parts must be installed according to Tommy Gate Company's specifications.

Tommy Gate Company will not pay labor for removing other equipment to gain access to Tommy Gate Equipment. Tommy Gate Company will not pay labor for time on the road to and from a service call.

Tommy Gate Company reserves the right to disallow or reduce claims for parts which have been damaged due to misuse, abuse, accidents or improper shipping; or parts which have been incorrectly or unnecessarily replaced.

The warranty is void if the product has been subject to other than normal use. **THERE ARE NO WARRANTIES, EXPRESS OR IMPLIED, INCLUDING THE WARRANTY OF MERCHANTABILITY OR A WARRANTY OF FITNESS FOR A PARTICULAR PURPOSE EXTENDING BEYOND THAT SET FORTH ABOVE.**

## **B. WARRANTY CLAIMS HANDLING PROCEDURE:**

The following procedures are required when an authorized distributor submits a warranty claim for a defective Tommy Gate part:

1. Before any expense is incurred, but after the problem has been diagnosed, the authorized distributor should contact Tommy Gate Company's Warranty Department to discuss the problem and its correction.
2. If it is determined that the condition is potentially covered by Tommy Gate Company's warranty, the authorized distributor will receive instructions on how to proceed. A decision will be made to either repair or replace the product or part in question.
3. If the product or parts are to be repaired, the authorized distributor will receive a **WARRANTY REQUEST NUMBER.**



## WARRANTY GUIDELINES



4. If the product or parts are to be replaced, the authorized distributor will be instructed to either hold the parts for inspection by a representative, in which case the authorized distributor will receive a **WARRANTY REQUEST NUMBER**, or the authorized distributor will be asked to return the product for inspection to Tommy Gate Company, in which case the authorized distributor will receive a **RETURN GOODS AUTHORIZATION NUMBER**. Under no circumstances are parts to be returned without a **RETURN GOODS AUTHORIZATION NUMBER**.
  
5. After the repair or replacement work is completed, the authorized distributor will submit the claim to Tommy Gate Company with the following information:
  - a. Tommy Gate Company **WARRANTY REQUEST** and/or **RETURN GOODS AUTHORIZATION NUMBER**.
  - b. Tommy Gate model number.
  - c. Tommy Gate serial number.
  - d. Tommy Gate part number involved and a description of the apparent problem or defect.
  - e. Authorized distributor performing warranty work.
  - f. Person responsible for warranty work (contact).
  - g. Distributor from whom liftgate was purchased.
  - h. Liftgate owner's name, address, and phone number.
  - i. Action taken, cost involved, complete with work orders and parts expense invoices.
  
6. If defective parts are to be returned to Tommy Gate Company, the parts:
  - a. Must be packaged for each individual warranty return. No multiple warranty claims in the same box.
  - b. Must be returned "freight prepaid" to Tommy Gate Company's location.
  - c. Must be clearly marked with the **RETURN GOODS AUTHORIZATION NUMBER** on the outside of the package.

Warranty claims must be submitted by the Authorized Distributor on behalf of their customer as part of their customer assistance.

Warranty claim acceptance or rejection is based solely upon defective part inspection and a review of the claim date (outlined in step 5 above) as they apply to the requirements of the Tommy Gate Warranty. Claim reimbursement after acceptance is governed by those allowances previously agreed upon between Tommy Gate Company and the Authorized Distributor (as outlined in steps 1-4 above).

Any warranty claims submitted without a **WARRANTY REQUEST NUMBER** or **RETURN GOODS AUTHORIZATION NUMBER** and the necessary information will be denied.

# 700-2000 G<sup>2</sup> SERIES

## REPAIR PARTS DRAWING

### FOR ALL MODEL WIDTHS

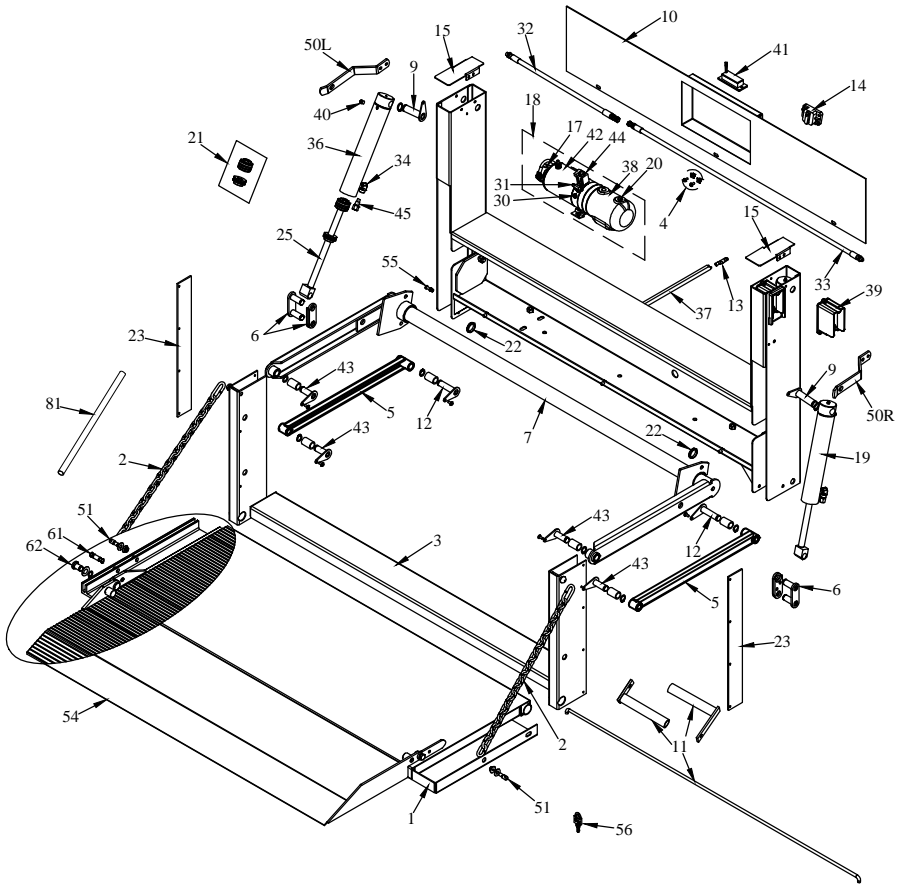





# 700-2000 G<sup>2</sup> SERIES REPAIR PARTS LIST



ITEM#	DESCRIPTION	ITEM#	DESCRIPTION
1	Platform	38	Tank
2	Platform Chain	39	Timed Control
3	Sub Assembly	40	Vent Plug-Cylinder
4	License Plate Mount Kit	41	License Plate Light
5	Lower Arm Assembly	42	Motor Only
6	Cylinder Clevis Assembly	43	3/4" Upright Front Arm Pin
7	Upper Arm Assembly	44	"Lower" Solenoid
9	7/8" Upright Cylinder Pin	45	Flow Control
10	Box Cover	50L	Driver Side Latch Kit
11	Torsion Spring	50R	Passenger Side Latch Kit
12	3/4" Upright Arm Pin	51	Platform Latch Pin Assembly
13	Copper Lug	54	Flipper
14	Manual Reset Circuit Breaker	55	Drop Away Pin Assembly
15	Upright Cap	56	Padlock w/ Keys
17	"Raise" Solenoid	61	Platform Chain Pin
18	Pump & Motor	62	Flipper Rivet
19	Cylinder	70	Outer Platform Assembly(LD)
20	Vent Plug	71	Platform Insert(LD)
21	Cylinder Seal Repair Kit	72	Latch Pin and Lanyard
22	Split Plastic Grommet	73	LD Insert Pivot Pin Assembly
23	Sub Assembly Belting	74	LD Access Cover
25	Cylinder Shaft Kit	75	Cotterless Hitch Pin
30	Check Valve	76	LD Insert Latch Pin Assembly
31	Tee Fitting	77	Short Insert Link Assembly(LD)
32	Hydraulic Hose-Left	78	LD Insert Handle
33	Hydraulic Hose-Right	79	Long Insert Link Assembly(LD)
34	90° Cylinder Elbow	80	Belting(LD)
36	Cylinder Barrel Kit	81	Cloth Chain Cover
37	4 Ga. 2 Wire Electric Cable		

**Note:**

The item number **is not** the part number. Please have the model number and serial number available before calling for repair parts.





# NOTICE

**TOMMY GATE ISO GRADE 32 HYDRAULIC FLUID  
OR ISO GRADE 32 EQUIVALENT  
RECOMMENDED.**

**WITH THE USE OF AUTOMATIC TRANSMISSION  
FLUID (ATF) OR TOMMY GATE WINTER GRADE  
HYDRAULIC FLUID THE CYLINDERS MAY BEGIN  
TO MAKE NOISE. WHILE THERE WILL BE NO  
DAMAGE TO THE HYDRAULIC SYSTEM, IT MAY  
BECOME A NUISANCE. AN OIL ADDITIVE CAN BE  
USED TO ELIMINATE THE PROBLEM.**

**DO NOT USE AN ADDITIVE THAT IS NOT  
APPROVED BY TOMMY GATE.**

**THE FOLLOWING ADDITIVES ARE APPROVED:**

- 1) Caterpillar part# 1U-9891



**THIS PAGE**  
**INTENTIONALLY LEFT**  
**BLANK**





**America's First Name  
in Liftgates™**

**Manufacturing Plant:  
83 Bus Brown Drive  
Woodbine, Iowa 51579  
FAX (712) 647-2417**

**Corporate Offices:  
33717 N. Scottsdale Rd. Ste 120  
Scottsdale, AZ 85266  
FAX (602) 955-3902**

**(712) 847-8000  
[www.tommygate.com](http://www.tommygate.com)**

