

STOWAWAY

Tailgates By THIEMAN

M16, 20, 25, 30 MLB16, 20, 25, 30 OWNERS MANUAL/PARTS LIST

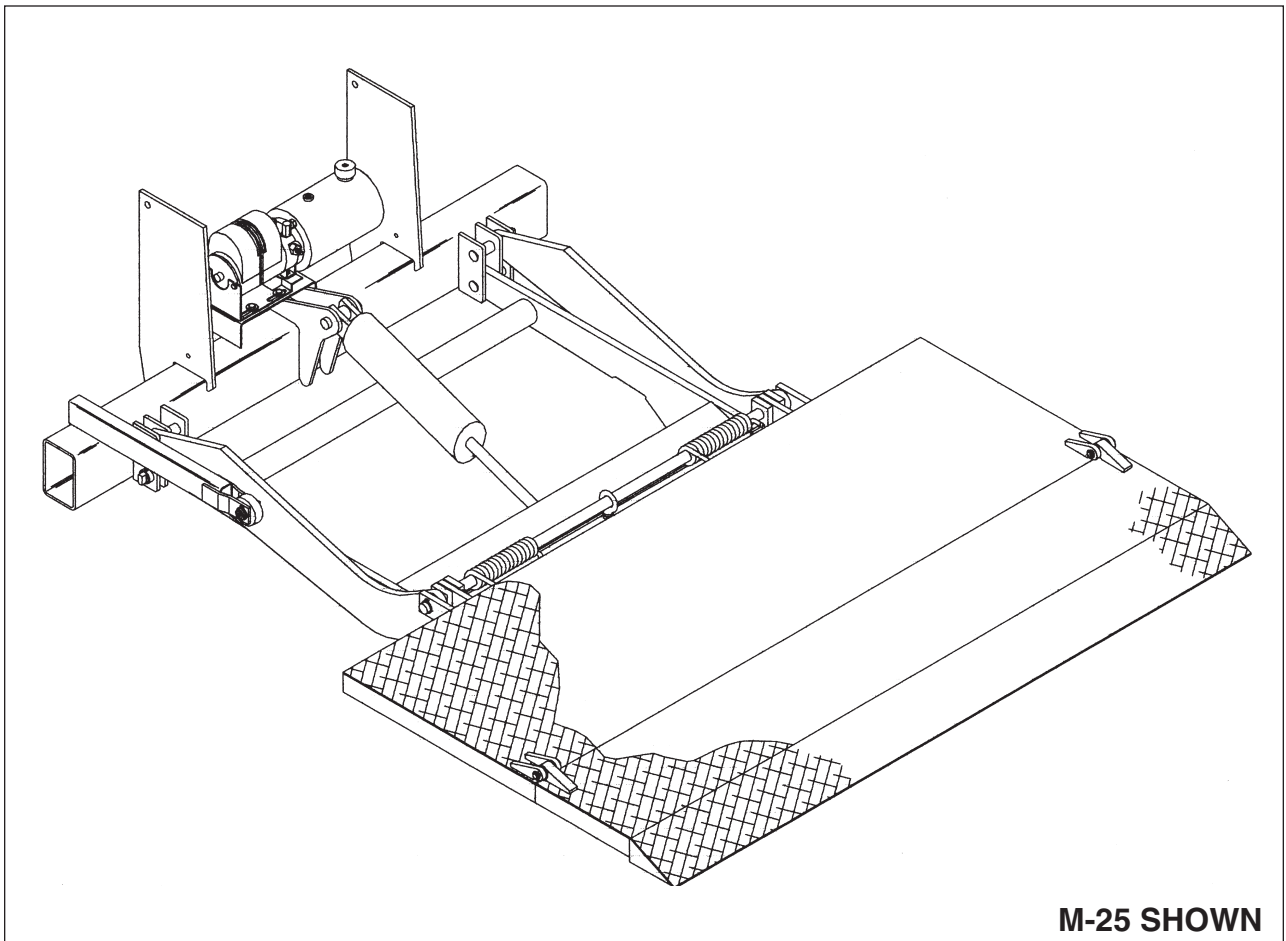

M-25 SHOWN



IMPORTANT! KEEP IN VEHICLE!

PLEASE READ AND UNDERSTAND THE CONTENTS OF THIS
MANUAL BEFORE OPERATING THE EQUIPMENT.



THIEMAN
TAILGATES, INC.

600 East Wayne Street
Celina, Ohio 45822

Phone: 419-586-7727 Fax: 419-586-9724

TABLE OF CONTENTS

WARNINGS.....	2
PARTS ORDERING PROCEDURE	3
OPERATING INSTRUCTIONS.....	5
MAINTENANCE GUIDE	5
SEMI-ANNUAL INSPECTION	6
ELECTRICAL PICTORIALS	7
INSPECTION AND LOCATION OF DECALS.....	8
PLATFORM ASM	9 & 10
SPACER ASM.....	11
TRUNNION, LIFT ARM, AND IDLER ARM ASM.....	12 & 13
PUMP ASM ELECTRIC CONTROL POWER DOWN	14
PUMP ASM ELECTRIC CONTROL GRAVITY DOWN	15
TROUBLESHOOTING GUIDE.....	16-19

FOR YOUR RECORDS

Model No. _____ Date Purchased _____

Serial No. _____

NOTE: When Ordering Parts Be Sure To Include This Information!

WARNING!

The following list of warnings are to be read before operating the M series liftgate.

- + Read this Owners Manual and all of the decals on the liftgate BEFORE operating the liftgate.
- + All protective covers and guards must be in place before operating the liftgate.
- + DO NOT operate the liftgate if you do not have a thorough knowledge and understanding of the operation of the liftgate.
- + NEVER OVERLOAD THE LIFTGATE. The maximum rated capacity of the M series liftgate differs with each model as follows:

M16 – 1600LBS	M25 – 2500LBS
M20 – 2000LBS	M30 – 3000LBS
- + Never use the liftgate if it makes any unusual noises, has vibrations, or fails to operate freely.

- + Make certain that the area below the platform is clear before and at all times during the operation of the liftgate.
- + Keep hands and feet clear of all pinch points.
- + The platform must be in the closed position and the transit latch engaged properly before transit.
- + Always load as close to the center of the platform and as close to the vehicle as possible. See figure 1.
- + Never operate lift trucks on or over any part of the platform.
- + Load and unload the platform from the rear and not from the side of the platform.
- + Only operate liftgate when vehicle is on level ground and the parking brake is set.
- + Follow the maintenance guide as outlined in this manual.
- + DO NOT attempt any repairs unless you are a qualified and authorized THIEMAN distributor.
- + If any repairs, adjustments, or maintenance not covered in this manual are required, contact your nearest Thieman distributor or the factory.
- + DO NOT ride the liftgate, it is not intended as a personal lift.
- + This liftgate is intended for the use of loading and unloading cargo only, it is not to be used for anything other than this.
- + DO NOT modify this liftgate. Altering this liftgate may cause serious personal injury or damage the liftgate and will void all warranties.

PARTS ORDERING PROCEDURE



When ordering parts, please include all the information asked for below. If this information is not available, a complete written description or sketch of the required part will help Thieman identify and deliver the needed part to you.

THE FOLLOWING INFORMATION MUST BE INCLUDED:

1. Serial Number – Thieman liftgate serial numbers can be found on the tag located on the front side of the trunnion tube.
2. Model Number and Capacity.
3. Platform size and Material – Steel or Aluminum.
4. Part number.
5. Description.
6. Quantity required.

WATER LEVEL LOADING

When a maximum load is to be raised or lowered, this load must be centered on the load bearing platform, both front to back and side to side.

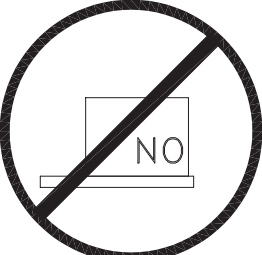
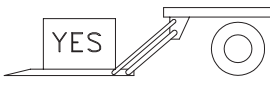
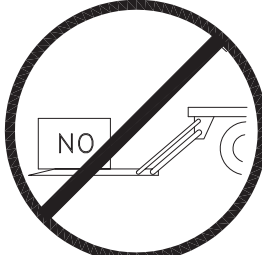
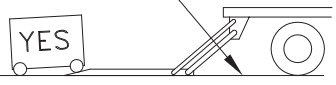
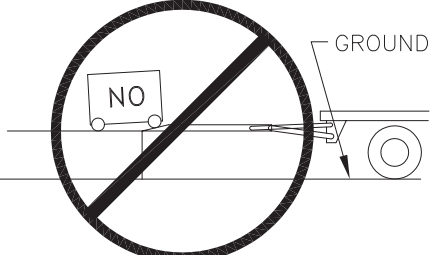
 WARNING		
<p>SIDE TO SIDE</p>   <p>DO NOT OFF CENTER LOAD</p>	<p>FRONT TO BACK</p>   <p>DO NOT OFF CENTER LOAD</p>	<p>GROUND</p>   <p>DO NOT LOAD OR UNLOAD WITH RAMP OFF GROUND</p> <p style="text-align: right;"><small>4671050D</small></p>

OPERATING INSTRUCTIONS

Caution

Be sure to operate liftgate at a safe distance and never improperly load platform as this may cause personal injury or damage to the liftgate.

UNFOLDING OF PLATFORM

1. Raise platform by pushing up switch until stow pin on platform is off the spacer latch.
2. Move spacer handle counterclockwise to disengage spacer latch and hold.
3. Lower the platform by pushing the down switch until the lift arms contact the ground.
4. Grasp platform handle on curb side and rotate outward to a horizontal position.

RAISING OF PLATFORM

5. Push up switch to raise platform to bed height.

LOWERING OF PLATFORM

6. Push down switch to lower platform to the ground.

CLOSING OF PLATFORM

7. Lower platform to the ground.
8. Fold over extension and grasp platform handle to raise manually to vertical position.
9. Push up switch to raise completely until stow pin and spacer latch have engaged for stowing.

THERMAL DATA: To avoid overheating the motor do not operate this unit for more than 8 cycles/10 minutes with the maximum load. The motor then must be allowed to completely cool down to ambient temperature before cycling the lift again. This unit also has a 15% duty cycle, which means the liftgate can be cycled no more than 3 cycles/10 minutes constantly with a maximum load.

MAINTENANCE GUIDE

The following inspection and maintenance operations should be performed at the recommended intervals or anytime the liftgate shows signs of abuse, and improper or abnormal operation.

MONTHLY INSPECTION AND MAINTENANCE

Operate the liftgate throughout its entire operational cycle and check the following:

1. Check that there are no unusual noises or vibrations.
2. Check platform height relative to bed height. If platform is lower, adjust cylinder with a 13/16 wrench to obtain the necessary height.
3. Check for apparent damage to the liftgate such as bent or distorted members, any cracked welds which may have resulted from overloading or abuse.
4. Check for excessive wear in the following areas:
 - A. Platform hinge pins and lift arms
 - B. All cylinder pins, bolts, and clevis
 - C. Platform extension pivots
 - D. Linkage pins and clevises
5. Check that the platform pivot pins are in place and retained by their proper retainers.
6. Check that all protective covers and guards are properly in place and secured.
7. Check for oil leaks in these areas:
 - A. Lift cylinder
 - B. Hydraulic hose-replace if it shows signs of wear or cracking.
 - C. Hydraulic fittings-tighten or replace as may be required to stop leakage.
8. Check the oil level in the pump reservoir. With the liftgate in the lowered position and the platform at ground level the oil should be within 1/2" from the top of the reservoir. See chart below for oil applications.
9. Check that all wiring and battery cable connections are tight and free of corrosion.

10. Lubrication of the M series liftgate should be as follows for all user conditions:

<u>Area of Tailgate</u>	<u>Type of Lubrication*</u>	<u>Frequency</u>
Kicker roller asm	Grease	50 cycles
Pump oil change	see chart below	yearly
Control handle pivots	SAE 10 or 20 oil	50 cycles
Platform extension pivots	SAE 10 or 20 oil	50 cycles

The major pivot points of the M series liftgate have special bushings that do not require lubrication.

For -40 to 120 F use #0 Grade grease.

For -20 to 200 F use #1 Grade grease.

HYDRAULIC FLUID CHART	
Temperature Range	Acceptable Fluids
-75 to 165°F	Exxon Unavis J-26
-20 to 130°F	Dexron III Exxon Superflo ATF Shell Donax TG
-50 to 80°F	Shell Aero Fluid 4 Mobil Aero HFA Exxon Unavis J-13 MIL H-5606

11. Check the pump relief pressure and also the motor amperage at this pressure. These values should be as follows:

<u>Model</u>	<u>Max. Amp. Draw</u>	<u>Relief Pressure (psi)</u>
M16	175	2000
M20,M16 wedge	190	2525
M20 wedge	175	2000
M25 wedge,M30	190	2525
M25	230	3000

Semi-Annual Inspection

1. Perform the procedures outlined in the Monthly Inspection and Maintenance.
2. Repaint original painted components as necessary to prevent rust and corrosion from reducing structural integrity of original components.
3. Inspect pump motor by:
 - A. Disconnecting battery cable
 - B. Remove motor end cover
 - C. Examine the armature brushes for wear. (Brushes should be replaced if they are less than 1/8" long).
 - D. Clean all residue out from inside of the motor housing.
 - E. Apply several drops of light weight machine oil to the armature shaft bearing in the motor end cover and reassemble the motor end cover.
4. If the hydraulic oil in the reservoir is dirty:
 - A. Unfold platform and lower platform to the ground.
 - B. Drain the oil from the hydraulic system and flush the entire system.
 - C. Remove reservoir from pump and clean suction line filter. Also clean out any contaminants inside reservoir. Remount reservoir when completed.
 - D. Replace the oil as outlined in Section 9 under Monthly Maintenance and Inspection.

ELECTRICAL PICTORIAL

ELECTRIC CONTROL GRAVITY DOWN

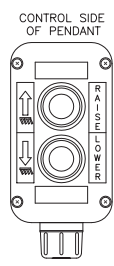
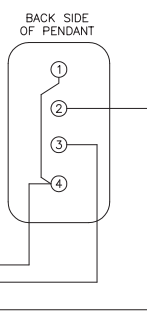
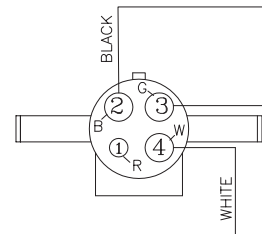
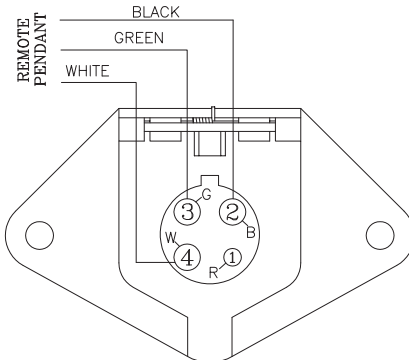
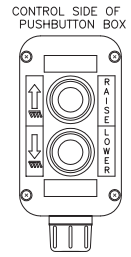
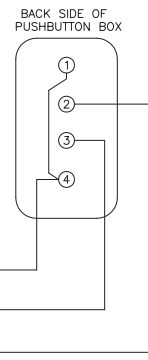
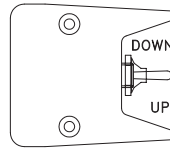
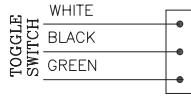
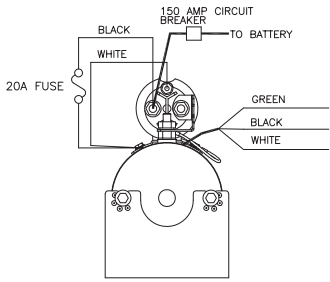

POWER DOWN ELECTRIC CONTROL (TOGGLE, PUSHBUTTON, OR REMOTE PENDANT)

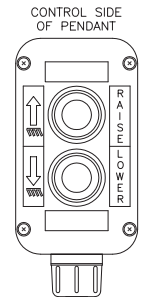
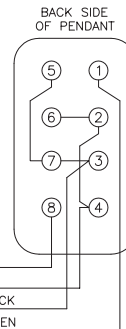
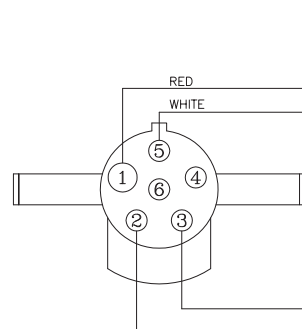
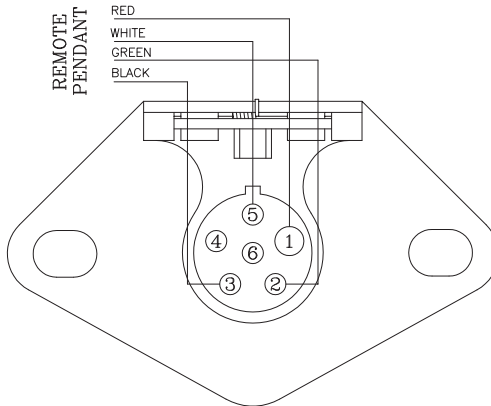
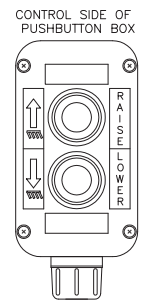
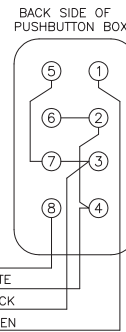
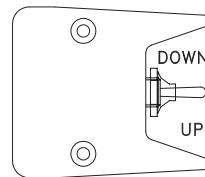
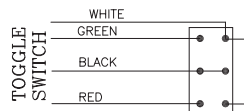
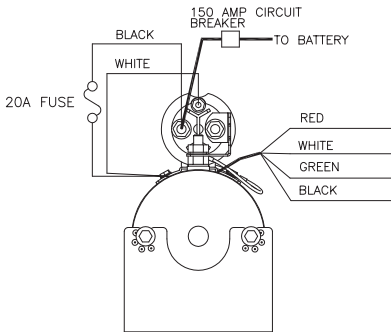

INSPECTION AND LOCATION OF DECALS

Inspect all decals listed below to be certain they are in the proper location and they are legible.

ALL DECALS MUST BE IN PLACE AND LEGIBLE OR ALL WARRANTIES ARE VOID!

Item	Part Name	Part Number
1	Warning Decal-off center	4671050
2	Fast Idle Decal	4650150
2	PTO Decal	4650140
3	Danger Decal-no riding	4609
4	Operating Decal	4650890
5	Capacity Decal-1600#	4650750
5	Capacity Decal-2000#	4650100
5	Capacity Decal-2500#	4650110
5	Capacity Decal-3000#	4650120
6	Warning Decal-pinch point	4604
7	Handle decal	4605
8	Thieman Nameplate	4650800
9	Urgent Warning Decal	4650530
10	Reflector (3)	5705
11	Wiring Decal-Gravity Down	4612
11	Wiring Decal-Power Down	4614
12	Warning Decal	4620
13	Caution Decal	4650770

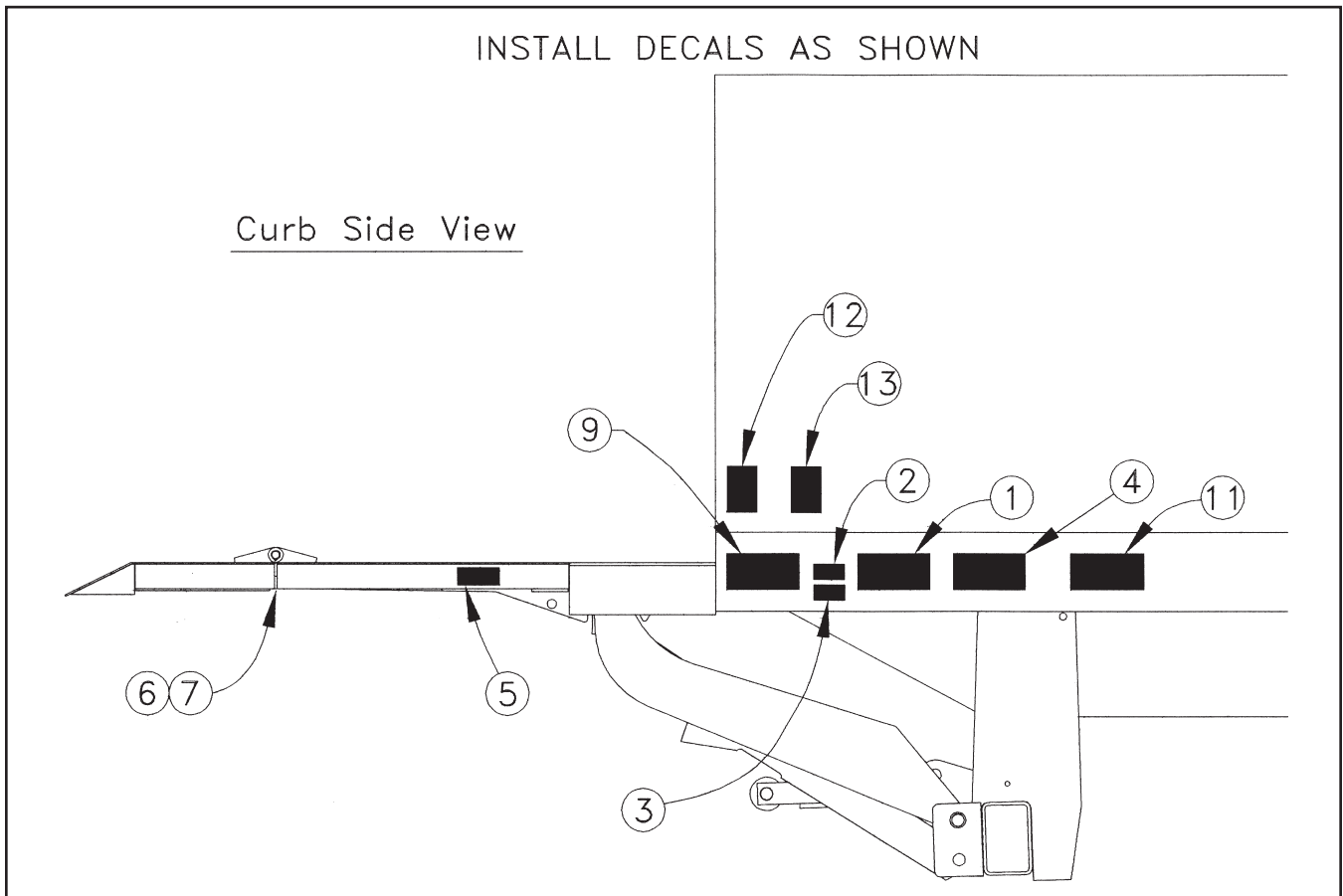

PLATFORM ASSEMBLY - M16/20

Item	Part Number	Description	Qty.
1	3423-001	Platform Asm 7236	1
1	3422-001	Platform Asm 7242	1
1	3423-002	Platform Asm 8436	1
1	3422-002	Platform Asm 8442	1
1	3421-001	Platform Asm 7232	1
1	3421-002	Platform Asm 8432	1
2	31224-001	Main Section Weld 7236, 7242	1
2	31224-002	Main Section Weld 8436, 8442	1
2	31222-001	Main Section Weld 7232	1
2	31222-002	Main Section Weld 8432	1
3	31097-001	Extension Weld 7236	1
3	31155-001	Extension Weld 7242	1
3	31097-002	Extension Weld 8436	1
3	31155-002	Extension Weld 8442	1
3	31717-001	Extension Weld 7232	1
3	31717-002	Extension Weld 8432	1
4	3023-001	Support Tube	1
5	5101260	Spring-M or MLB	2
6	5050	Pin	1
7	8120378	Nut .50	1
8	9414074	Locknut .50	1
9	5781017	Retaining Ring	5
10	5051	Pin	1
11	5056	Pin	2
12	5711	Shoulder Eye Bolt	1
13	8107-011	Washer .62	2
14	5504-022	Bushing	4

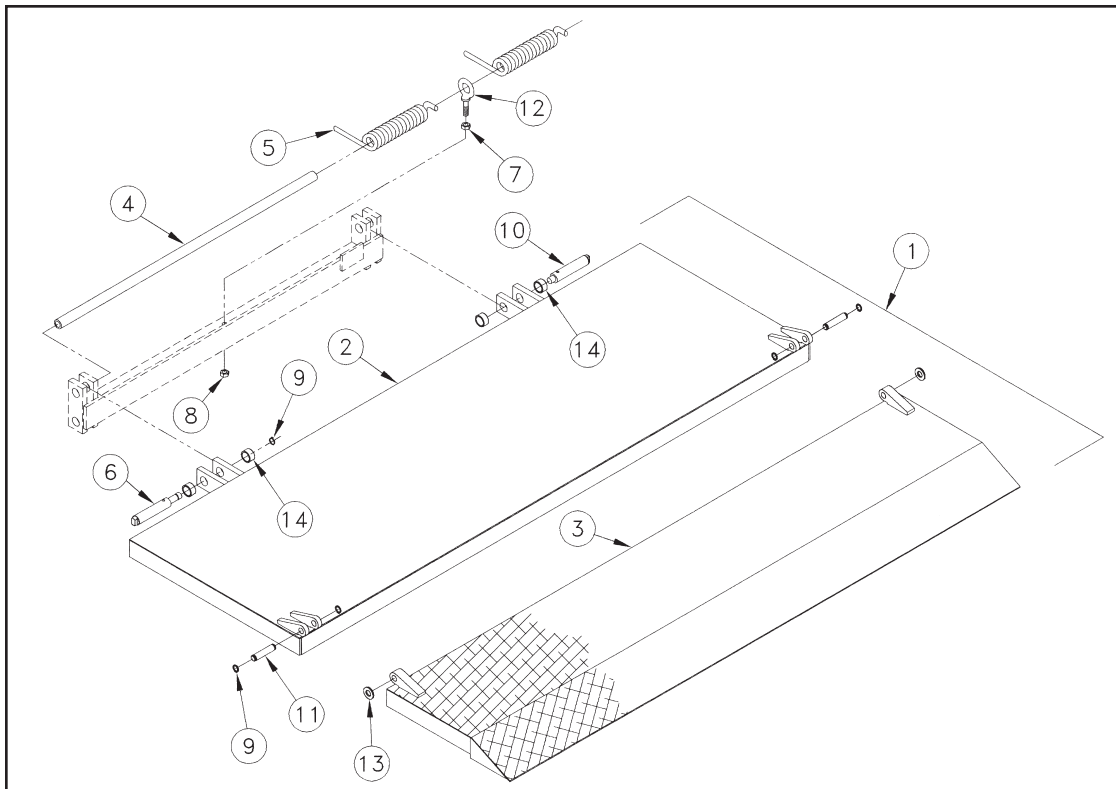

PLATFORM ASSEMBLY - M25/30

Item	Part Number	Description	Qty.
1	31420-001	Platform Asm 7236	1
1	31426-001	Platform Asm 7242	1
1	31420-002	Platform Asm 8436	1
1	31426-002	Platform Asm 8442	1
1	31421-001	Platform Asm 7232	1
1	31421-002	Platform Asm 8432	1
2	31418-001	Main Section Weld 7236, 7242	1
2	31418-002	Main Section Weld 8436, 8442	1
2	31417-001	Main Section Weld 7232	1
2	31417-002	Main Section Weld 8432	1
3	31097-001	Extension Weld 7236	1
3	31155-001	Extension Weld 7242	1
3	31097-002	Extension Weld 8436	1
3	31155-002	Extension Weld 8442	1
3	31717-001	Extension Weld 7232	1
3	31717-002	Extension Weld 8432	1
4	3023-001	Support Tube	1
5	5101260	Spring-M or MLB	2
6	5050	Pin	1
7	8120378	Nut .50	1
8	9414074	Locknut .50	1
9	5781017	Retaining Ring	5
10	5051	Pin	1
11	5056	Pin	2
12	5711	Shoulder Eye Bolt	1
13	8107-011	Washer .62	2
14	5504-016	Bushing	4

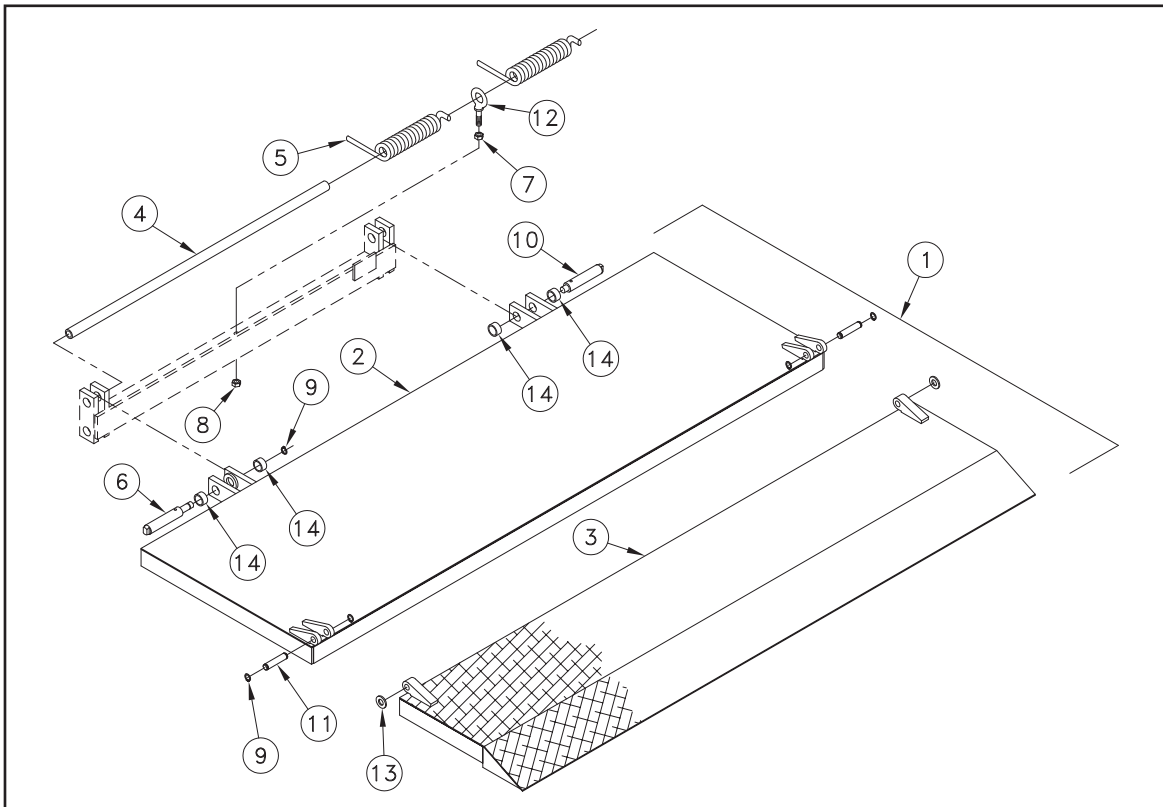

SPACER ASSEMBLY

Item	Part Number	Description	Qty.
1	3500	Spacer Asm	1
2	2404-002	Control Shaft	1
3	31592	Latch	1
4	5101100	Spring	1
5	5701043	Handle	1

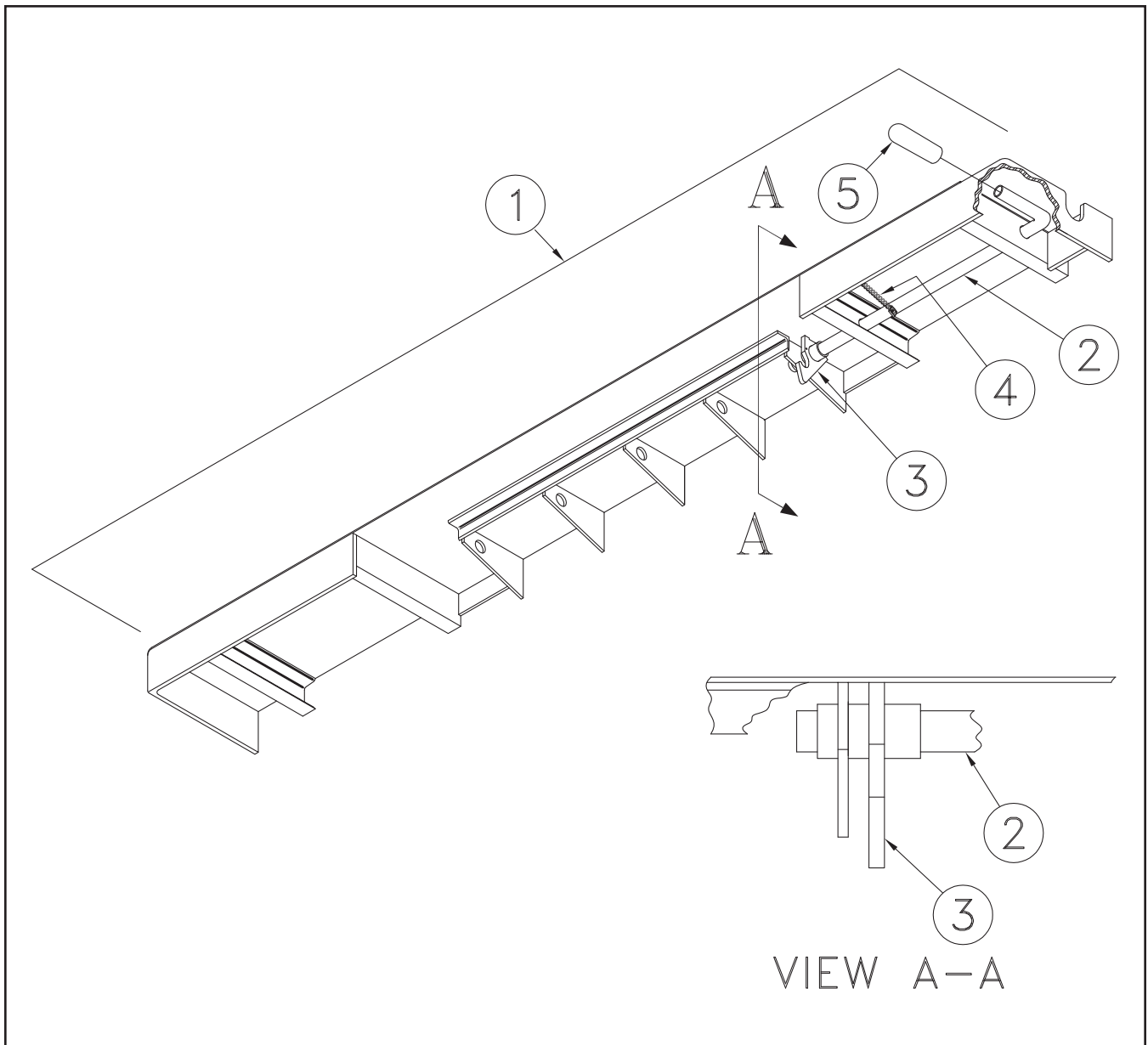

TRUNNION, LIFT ARM, AND IDLER ARMS - M16/20

Item	Part Number	Description	Qty.
1	31422-001	Trunnion Weld-M	1
1	31422-002	Trunnion Weld-MLB	1
1	31422-003	Trunnion Weld-Pintle Bracket	1
2	21026	Mounting Plate	2
3	31234	Idler Arm	2
4	31424	Lift Arm-M16/20	1
4	31429	Lift Arm-M20 Pintle Bracket	1
5	31232	Pivot Bar Weld-Standard M	1
5	31233	Pivot Bar Weld-Wedge & MLB	1
6	5701330	Roller	1
7	5031	Pin	1
8	5781008	Retaining Ring	2
9	8271291	Zerk	1
10	5047	Pin	4
11	5702371	Spring Pin	4
12	5049	Pin	2
13	5504-005	Bushing	6
14	5708-001	Spring Pin	4
15	5504-018	Bushing	2
16	5504-022	Bushing	2

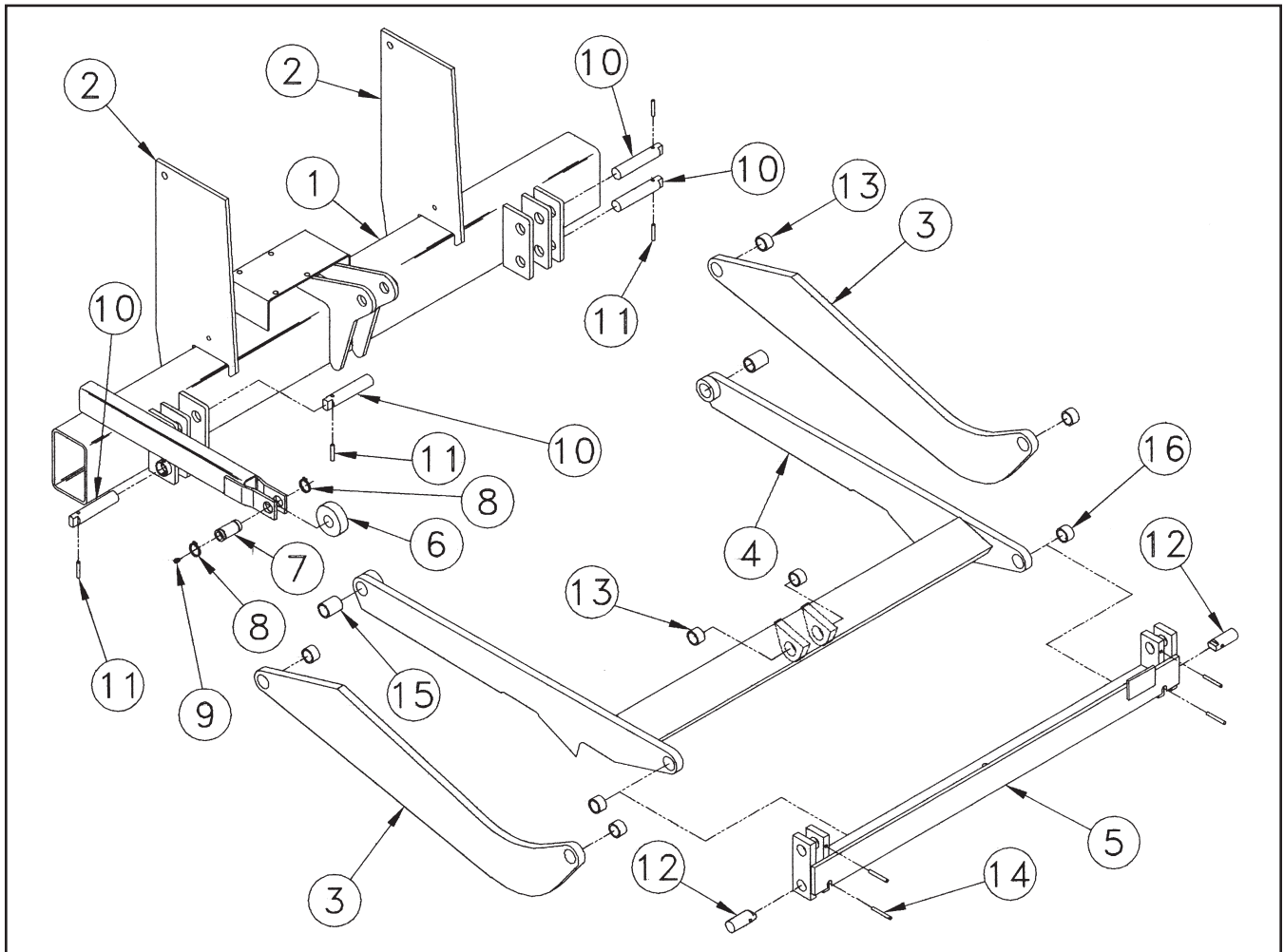

TRUNNION, LIFT ARM, AND IDLER ARMS - M25/30

Item	Part Number	Description	Qty.
1	31412-001	Trunnion Weld-M	1
1	31412-002	Trunnion Weld-MLB	1
1	31412-003	Trunnion Weld-Pintle Bracket	1
2	21030	Mounting Plate	2
3	31413	Idler Arm	2
4	31414	Lift Arm	1
4	31428	Lift Arm-Pintle Bracket	1
5	31416	Pivot Bar Weld-Standard M	1
5	31427	Pivot Bar Weld-Wedge & MLB	1
6	5701330	Roller	1
7	5031	Pin	1
8	5781008	Retaining Ring	2
9	8271291	Zerk	1
10	5047	Pin	4
11	5702371	Spring Pin	4
12	5075	Pin	2
13	5504-005	Bushing	2
14	5708-001	Spring Pin	4
15	5504-017	Bushing	2
16	5504-016	Bushing	6

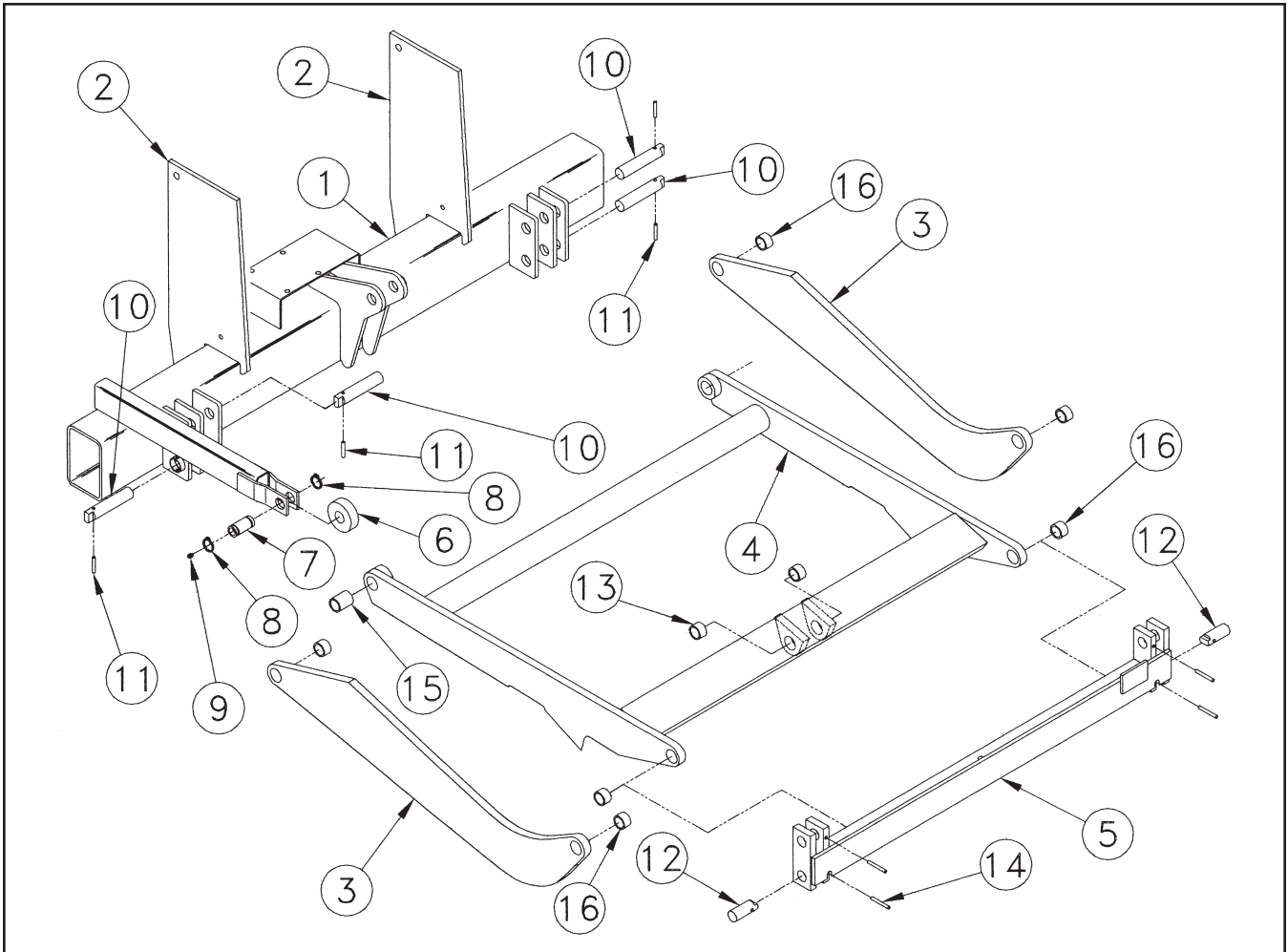

PUMP ASSEMBLY-POWER DOWN - M16/20/25/30

Item	Part Number	Description	Qty
1	4404	Pump Asm-Items 2 to 6	1
2	4421420	Pump Bracket	1
3	4421350	Mounting Bracket	1
4	4423520	Motor 8111	1
5	4468	Solenoid Start Switch	1
6	4420410	Breather Cap	1
7	5704	Cover	1
8	5700100	Strap	1
9	4930-001	MF-MAORB 90°	3
10	4948-001	Flow Control - 1.5 GPM	1
11	4936-001	MAORB-MAORB 90°	1
12	5053	Pin	1
13	4299	Cylinder Asm-M16/20/25, M16 Wedge	1
13	4298	Cylinder Asm-M20/25 Wedge, M30	1
14	4300030	Battery Cable #2 X 25'	1
15	4350	Cable Lug	1
16	8180126	Screw .38 x 1.50	5
17	8106-010	Internal Tooth Lockwasher .38	10
18	8120377	Nut .38	5
19	8120388	Flatwasher .38	4
20	31445	Toggle Switch Assembly	1
21	5504-009	Bushing	1
22	4422860	Pushbutton Control-Optional	1
23	8111-005	Screw #10X .75	2
24	4318-002	Ground Cable #2 x 2'	1
25	8104-006	Screw .31 x 1	1
26	5702371	Spring Pin	1
27	5059	Pin	1
28	5781008	Retaining Ring	2
29	4951-004	Hose 48"	2
30	4301770	Circuit Breaker 150 Amp	1
31	4318-001	Battery Cable #2 x 2'	1
32	4319-002	Shrink Wrap	1
33	4941-001	MJ-MORB Straight	1

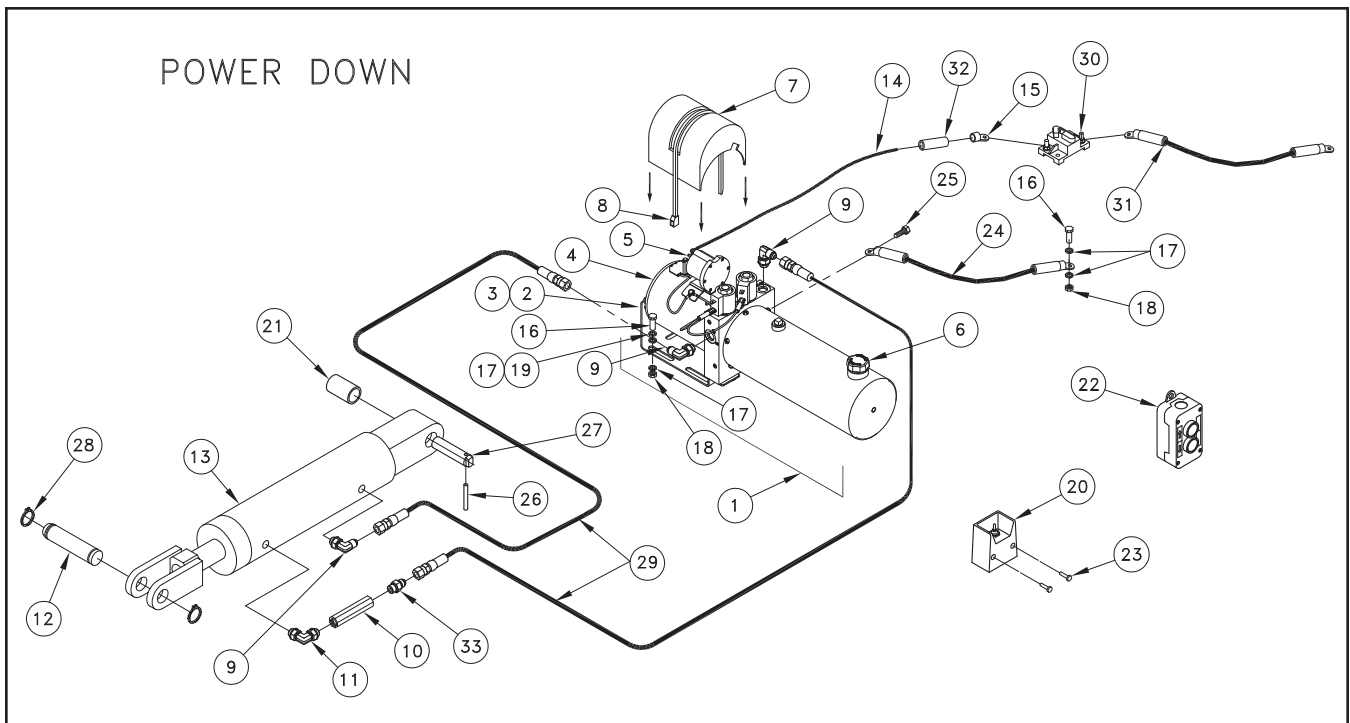

PUMP ASSEMBLY-GRAVITY DOWN - M16/20/25/30

Item	Part Number	Description	Qty
1	4400351	Pump Asm-Items 2 to 6	1
2	4421420	Pump Bracket	1
3	4421350	Mounting Bracket	1
4	4423520	Motor 8111	1
5	4468	Solenoid Start Switch	1
6	4420410	Breather Cap	1
7	5704	Cover	1
8	5700100	Strap	1
9	4930-001	MJ-MAORB 90°	1
10	4951-012	Hose 38"	1
11	4948-001	Flow Control 1.5 GPM	1
12	4936-001	MAORB-MAORB 90°	1
13	5053	Pin	1
14	4299	Cylinder Asm-M16/20/25,M16 Wedge	1
14	4298	Cylinder Asm-M20/25 Wedge, M30	1
15	4300030	Battery Cable #2 x 25'	1
16	4350	Cable Lug	1
17	8180126	Screw .38 x 1.50	5
18	8106-010	Internal Tooth Lockwasher .38	10
19	8120377	Nut .38	5
20	8120388	Flatwasher .38	4
21	4954	Breather	1
22	31446	Toggle Switch ASM	1
23	5504-009	Bushing	1
24	8111-005	Screw #10X .75	2
25	4422850	Pushbutton Control-Optional	1
26	4318-002	Ground Cable #2 x 2'	2
27	8104-006	Screw .31 x 1	1
28	5059	Pin	1
29	5702371	Spring Pin	1
30	5781008	Retaining Ring	2
31	4301770	Circuit Breaker 150 Amp	1
32	4318-001	Battery Cable #2 x 2'	1
33	4319-002	Shrink Wrap	1
34	4941-001	MJ-MAORB Straight	1

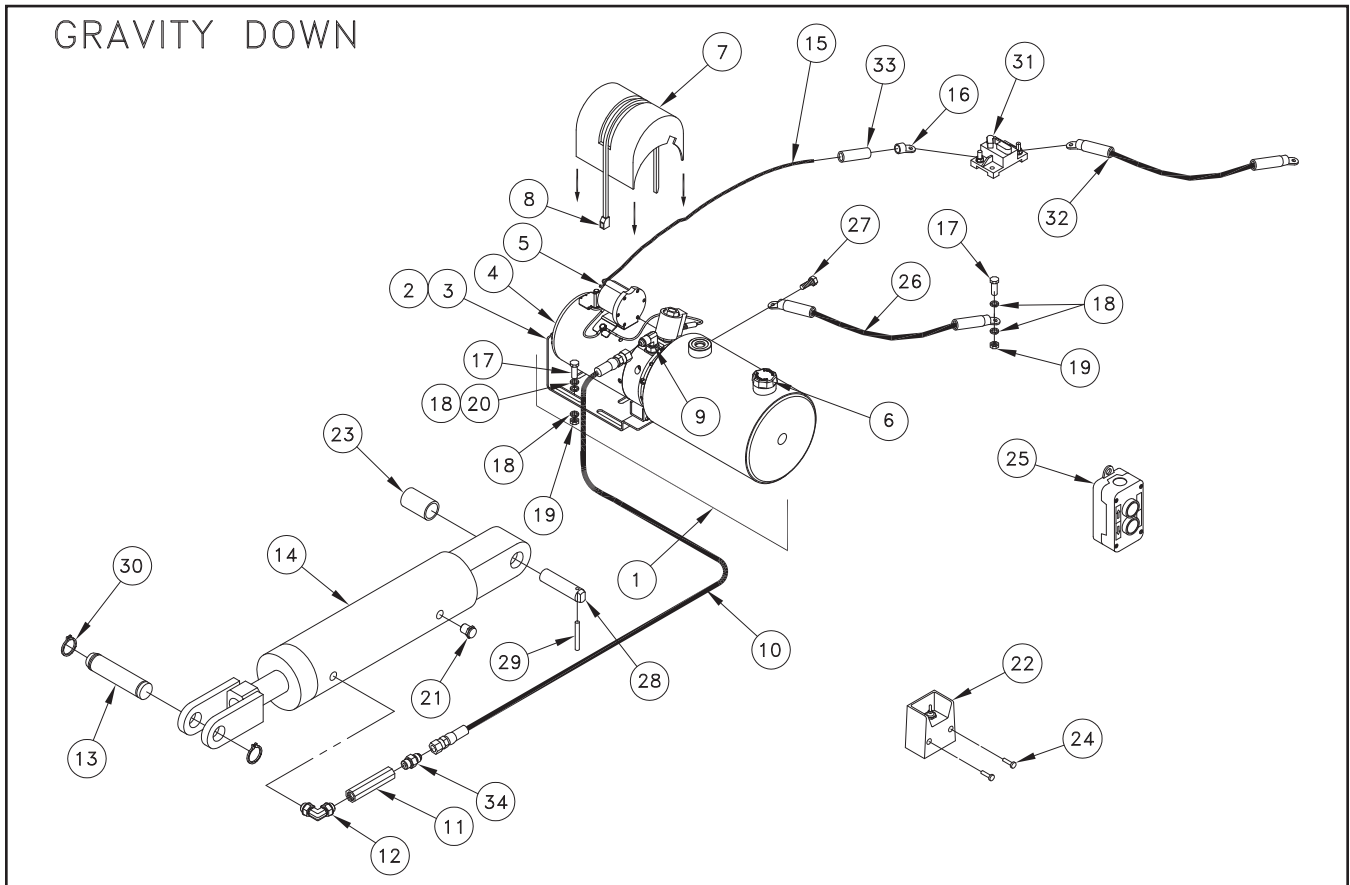

TROUBLESHOOTING GUIDE M16/20/25/30ET

- Test Equipment:**
1. 0-5000 psi pressure gauge
 2. DC voltmeter/ohm meter
 3. DC amp meter
 4. standard mechanics tools

Note: Please refer to the electrical diagrams and hose connection drawings in the liftgate's owners manual when troubleshooting. This guide is only for standard Thieman liftgates. Special liftgates with options other than those in the owner's manual will require special diagrams for troubleshooting. Read and understand this entire guide completely before doing any troubleshooting. Certain listed problems may be related to other problems listed so a comprehensive knowledge is required before proceeding.

Problem – Pump motor will not run in the raise mode

- Causes –
- a. Tripped circuit breaker
 - b. Blown 20A fuse
 - c. Defective or undercharged battery(ies)
 - d. Improper battery cable connection or improper ground connection
 - e. Defective or improperly wired raise switch
 - f. Defective or improperly wired solenoid start switch
 - g. Defective pump motor

- Corrections –
- a. Reset the circuit breaker located within 2ft of the liftgate supply battery(ies).
 - b. Replace 20A fuse.
 - c. The “at rest” voltage for the batteries without the engine running and under no load should be at least 12.5V. The minimum voltage between the motor stud and ground is 9V at maximum load conditions. If proper voltage is not present, charge or replace the batteries. The battery(ies) on the vehicle should be that which has a minimum 150 amp reserve capacity.
 - d. Trace battery and ground cable connections to locate improper connection(s). Make sure the ground cable is installed going from the aluminum pump base to bare metal on the truck frame. Make sure the ground cable from the batteries to the frame is a heavy 2ga. cable and that it too is connected to bare metal on the frame. Make sure there is 12.5V present at the large terminal on the motor start solenoid where the 2ga. cable from the batteries is connected. Replace any damaged cables and repair any bad connections.
 - e. Check for voltage on the black wire at the control switch. If no voltage is present the black wire from the motor start solenoid is loose or broken and needs repaired. If voltage is present then check for voltage at the green and white wire on the switch with the switch in the “RAISE” position. If no voltage is present, replace the switch.
 - f. Check for voltage on the white wire at the motor start switch when the switch is activated. If no voltage exists the white wire is loose or broken between the switch and the motor start solenoid. Check that the purple ground wire on the start solenoid is connected properly and there are no bad connections. If there is voltage on the white wire and the coil does not energize or if there is no voltage present at the motor terminal then replace the start switch.

- g. With the switch activated in the “RAISE” position and the motor start solenoid is activated, check for voltage at the motor terminal. If voltage is present and the motor is not running, replace the motor.

2. Problem – Liftgate will not raise to bed with a load and the pump motor running

- Causes –
- a. Low hydraulic fluid
 - b. Overload condition
 - c. Improperly adjusted or defective main relief valve
 - d. Lift cylinder is bypassing, liftgate is drifting down
 - e. Broken hydraulic line
 - f. Clogged or disconnected suction line
 - g. Defective pump

- Corrections -
- a. Make sure the reservoir has the proper amount of fluid. Remove the breather cap and check the fluid line through the fill hole. The hydraulic fluid should be within 1/2” of the top of the reservoir with the liftgate in the lowered position. Fill with Dexron III automatic transmission fluid.
 - b. The power unit on the M is equipped with a lifting relief valve to prevent overloading of the liftgate. The relief settings should be as follows:

M16	2000 psi
M20, M16 wedge	2525 psi
M25, M20 wedge	2000 psi
M30, M25 wedge	2525 psi
 - c. See section “c” above for relief valve setting. Plumb a pressure gauge into the high pressure circuit of the liftgate. Remove all loads from the liftgate’s platform. Engage the “RAISE” switch until the liftgate is fully raised. Keep the “RAISE” switch engaged until the pump bypasses through the relief valve and note the pressure on the gauge at this time. If the rated relief pressure is not present during relief, adjust the high pressure relief valve setting as necessary. If the relief pressure is not attainable the relief valve must be cleaned and/or replaced or the pump is defective. See part “g” below.
 - d. If the liftgate will not raise with a load on the platform but empty is raising slowly or only partially, the cylinder may be bypassing. To check for a bypassing cylinder do the following. Lower the gate to the ground to relieve all pressure from the cylinder. Disconnect the cylinder from the liftarm. Press the “RAISE” switch until the cylinder is fully retracted. Disconnect the return line from the power unit and put the end of the line in a container to catch any oil which comes out during this test. Press the “RAISE” switch for 15 to 20 seconds and watch for a steady stream of fluid coming out of the return line into the container. If no steady stream of oil is present connect the hose to the butt end of the cylinder after removing the return line and fitting. Re-attach the return line and fitting to the rod end port. Put the loose end of the return line in a container to catch any oil, which comes out during this test. Press the “RAISE” switch until the cylinder is fully extended. Press the “RAISE” switch for 15 to 20 seconds and watch for a steady stream of fluid coming out of one of the disconnected hose ends into the container. Replace or rebuild any cylinder with fluid coming out of the return line, as this indicates fluid is bypassing the piston seals on the cylinder. Reconnect rebuilt or replaced cylinder and hoses as before.

- e. Broken or punctured hydraulic lines and fittings must be replaced with care to avoid injury from high pressure oil streams.
- f. With the liftgate at the ground, disconnect the power unit and remove the reservoir. Check to see if the suction tube is clogged or has fallen out of the pump base. Clean the screen or reattach the suction tube as required.
- g. If all else fails replace the power unit, it is probably worn out.

3. Problem – Liftgate will not lower

- Causes -
- a. Defective lowering solenoid coil or valve
 - b. Clogged or defective hydraulic lines, fittings or flow controls

- Corrections -
- a. With the “LOWER” switch engaged check for voltage on the green wire at the switch. If no voltage is present replace the switch. If voltage is present, with the “LOWER” switch engaged, check for voltage at the green wire on the lower solenoid valve coil terminal. If no voltage is present, the green wire from the “LOWER” switch is loose or broken and needs replaced. If there is voltage (minimum of 9.5 volts) and the valve is not opening to allow the gate to lower, either the lower coil is bad or the entire lower coil/valve assembly is bad. To check to see if the coil is defective, remove the green wire from the spade terminal on the lower coil and check for continuity between the spade terminal and the nut, which holds the coil on the valve stem. If continuity does not exist, replace the defective coil, otherwise replace the defective lower coil/valve assembly.
 - b. Remove any obstruction in the hoses, fittings or flow controls or replace any hose, fitting or flow control, which does not allow fluid to flow through freely.

4. Problem – Liftgate raises slowly – The raise speed of the M16/20/25/30 on a 54” bed height while empty at 70°F is approximately 7-12 seconds. The raise speed loaded for the same conditions is approximately 15-25 seconds. These speeds vary with each model.

- Causes -
- a. Overload condition
 - b. Cold weather
 - c. Partially blocked suction screen
 - d. Lift cylinder is bypassing
 - e. Improperly adjusted or defective raise relief valve
 - f. Low voltage and/or bad ground
 - g. Worn out pump

- Corrections –
- a. See section 2b
 - b. Refer to Owner’s Manual for alternative oils to use for cold weather conditions.
 - c. Remove reservoir and clean or replace suction screen as necessary.
 - d. See section 2d
 - e. See section 2c
 - f. The minimum voltage between the motor stud and ground is 9.5 volts at maximum load conditions. See section 1b and 1c.
 - g. After all other corrections are performed it will be necessary to replace the pump.

5. Problem – Foamy oil flowing from reservoir breather

- Causes -
- a. Air is present in the system
 - b. Flow control is on backwards
 - c. Inoperable flow control

- Corrections -
- a. Air can enter the system if the fluid level is low, see problem 2, part a, or if the suction tube is disconnected, see problem 2, part f. Also air may enter through fittings, which are not tightened properly, so check for any leaks around fittings or hoses. Once the source of the air is determined, the cylinder must be bled of all air. Most air can be removed from the system by lowering the gate to the ground to relieve all pressure from the cylinder, unpinning the cylinder and cycling them back and forth several times from fully extended to fully retracted and allowing the pump to bypass through the relief valves for a few seconds in each direction.
 - b. The flow control provided is rated at 1.5GPM or 3.0GPM. The arrow on the flow control must point away from the cylinder, designating the direction of the controlled flow. Correct as needed.
 - c. Remove and disassemble the flow control and check for excessive wear and contamination. Clean as needed and reassemble. If this does not correct the problem replace the flow control.

If you have any questions or problems that are not covered in this guide please call Thieman's Engineering Department at 1-800-524-5210.

