



SINCE 1932

OPERATORS MANUAL

OFF-ROAD ARTICULATED WATER TRUCKS



Curry Supply Co., 1477 Degol Industrial Drive, Hollidaysburg, PA 16648



800-3



TABLE OF CONTENTS

Sections

1. [Introduction & Safety](#) [Page 3](#)
2. [System Descriptions](#) [Page 4](#)
3. [Normal Operations](#) [Page 7](#)
4. [Maintenance](#) [Page 15](#)
5. [Schematics](#) [Page 23](#)
6. [Troubleshooting](#) [Page 39](#)
7. [Warranty Information](#) [Page 40](#)

SECTION 1

Introduction & Safety Messages

CONTACT US

Curry Supply Company

1477 Degol Industrial Drive, Hollidaysburg, PA 16648

service@currysupply.com CurrySupply.com

Parts 800.567.5127

Warranty Service 800.345.2829

MANUAL USAGE

This Operators Manual contains information to safely operate more than (1) configuration of "Curry Supply Articulating Off-Road Water Trucks". The parts shown may not reflect the exact configuration on your truck. "Custom" style trucks may have parts not listed. If your system is not covered in this manual, please contact Curry Supply Co. Support at 800.345.2829 or service@currysupply.com.

All personnel working on or operating the machine must become familiar with the following safety messages.

Due to the nature of these processes, ensure that all safety information, warnings, and instructions are read and understood before any operation or maintenance procedures are performed.

This manual does not supersede any local, state, or federal laws.

SAFETY MESSAGES

The following definitions are found throughout this manual and apply as follows:

WARNING

OPERATING PROCEDURES AND TECHNIQUES COULD RESULT IN PERSONAL INJURY OR LOSS OF LIFE IF NOT FOLLOWED CORRECTLY.

CAUTION

OPERATING PROCEDURES AND TECHNIQUES WHICH COULD RESULT IN DAMAGE TO EQUIPMENT IF NOT FOLLOWED CORRECTLY.

NOTE

OPERATING PROCEDURES AND TECHNIQUES THAT ARE CONSIDERED ESSENTIAL TO EMPHASIZE.



WARNING

IMPROPER USE OF EQUIPMENT
COULD CAUSE SERIOUS INJURY
OR DEATH. PLEASE READ AND
UNDERSTAND ALL INSTRUCTIONS.



WARNING

DO NOT OPERATE THE UNIT
WHILE INTOXICATED OR
EXTREMELY EXHAUSTED.



WARNING

WHEN OPERATING OR
WORKING ON THE UNIT, KEEP
HANDS AND BODY PARTS
CLEAR OF PINCH POINTS.



WARNING

DO NOT WALK ON TOP OF
THE VEHICLE. FALLING FROM
VEHICLE CAN RESULT IN
SERIOUS INJURY.



WARNING

CONTACT WITH LIVE
ELECTRICAL CIRCUITS COULD
DAMAGE EQUIPMENT OR
CAUSE INJURY.



CAUTION

DRAIN ALL WATER DAILY DURING
FREEZING TEMPERATURES.
FREEZING WATER CAN RESULT IN
DAMAGE TO EQUIPMENT.



WARNING

MOVING PARTS CAN CRUSH
AND CUT. KEEP HANDS, FEET,
HAIR, AND LOOSE CLOTHING
AWAY FROM MOVING PARTS.



WARNING

HIGH PRESSURE WATER. DO
NOT OPERATE THE SPRAY
VALVES OR CANNON UNTIL
ALL THE PERSONNEL ARE AT
A SAFE DISTANCE FROM THE
VEHICLE.



CAUTION

ADVERSE WEATHER CONDITIONS
CAN CAUSE EQUIPMENT DAMAGE.
WHENEVER POSSIBLE, PERFORM
MAINTENANCE INDOORS.



WARNING

THE VEHICLE IS EQUIPPED WITH A
BACK-UP ALARM. ALARM MUST
SOUND WHEN OPERATING THIS
VEHICLE IN REVERSE.



WARNING

ALWAYS WEAR THE PROPER
PPE WHILE OPERATING THE
UNIT.



WARNING

ALWAYS WEAR YOUR SAFETY
BELT WHILE DRIVING THE VEHICLE.
IF VEHICLE TIPS, STAY BUCKLED
AND INSIDE OF CAB AREA.



SECTION 2

System Descriptions

SIDE VIEW OF TRUCK EXAMPLE



REAR VIEW OF TRUCK EXAMPLE



FRONT VIEW OF WATER TANK EXAMPLE



SPRAY BAR

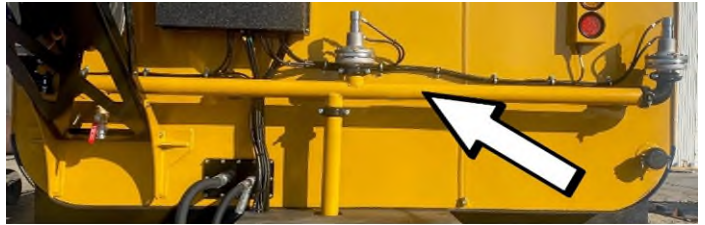

Located on the Rear and Front (optional) of the vehicle, this transfers water from the tank to the spray heads.

SPRAY HEADS



Located on the spray bars and top front of the water tank, this is where water sprays from.

FILL TUBE



Located on the front or rear of the water tank, this tube is used to fill the tank with water. The valve on the bottom will attach to a hose, with the other end attached to a water source.

WATER TANK FILL OPENING



Located on top of the tank, this is where water enters the tank by either hydrant fill or a water dump station.

WATER PUMP

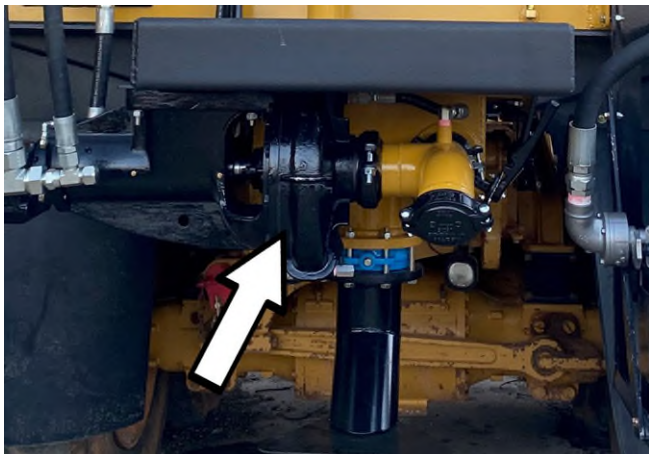

Located under the rear of the water tank, this pumps water through the tank and spray heads.

HOSE & HOSE REEL



Located on the rear of the water tank, equipped with either a 50' 1-1/2" (black) or 50' 1" (red) hose.

HOSE NOZZLE



Located on the end of the hose, water spray is controlled by a twist head control.

DUMP VALVE



Located on the rear, under the water tank, this will drain water from the tank.

SIGHT TUBE INDICATOR



Located on the rear of the water tank, this is a clear tube that displays the water level inside the water tank.

TOUCHPAD CONTROLLER



Located inside the cab, this allows the operator to control different modules installed on the truck.

WATER CANNON (if installed)

The water Cannon is located on top, between the water tank and cab. The direction of the cannon is controlled by a joystick in the cab.



SECTION 3

Normal Operations

This section provides the vehicle operator with step-by-step operating procedures for the installed systems. A quick reference operations card will be supplied and placed into the cab.

Prior to any operation, please perform a walk around inspection of the vehicle. Check specifically for any leaks or broken hoses.

VALVE OPERATION

Valves can be opened or closed by hand to allow or restrict water flow.

OPEN – Handle aligns with the tube or hose.

CLOSED – Handle is perpendicular, or at 90 degrees, with the tube or hose.

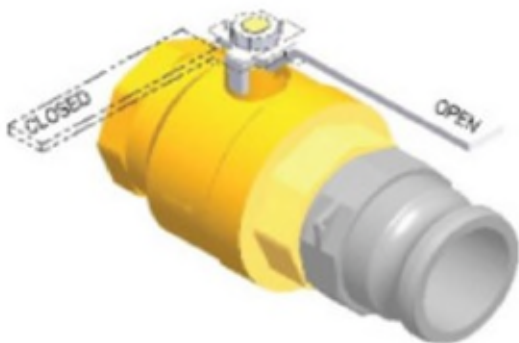

TANK FILLING OPERATIONS

CAUTION

FILL TANK WITH FRESH NON-POTABLE WATER ONLY. SALTWATER AND OTHER CHEMICALS COULD DAMAGE THE TANK INTERIOR COATING

HYDRANT TANK FILL

1. Ensure that the truck is in park and parking brake is ON.
2. Ensure the tank fill opening is clear of obstruction.



3. Connect the hose from the water source to the hydrant fill tube connector (A).

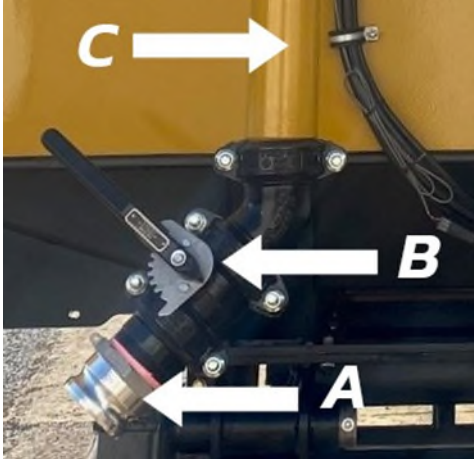

4. Rotate the fill valve handle (B) to "OPEN".
5. Turn the water ON from the water source.
6. Water will begin to flow through the fill tube (C) and into the fill hole on top of the tank. The operator can view the water level by viewing the clear sight tube located on the rear of the tank.



7. Once the water tank is filled to the desired level, turn OFF the water source.

CAUTION
FILL TANK TO AT LEAST 1/4 FULL TO OPERATE ANY WATER OPERATIONS

8. CLOSE the fill valve handle.
9. Disconnect the hose from the hydrant fill tube connector.
10. OPEN valve fill handle to drain any excess water to avoid freeze/water damage.

HYDREMA CREEK FILL OPERATION

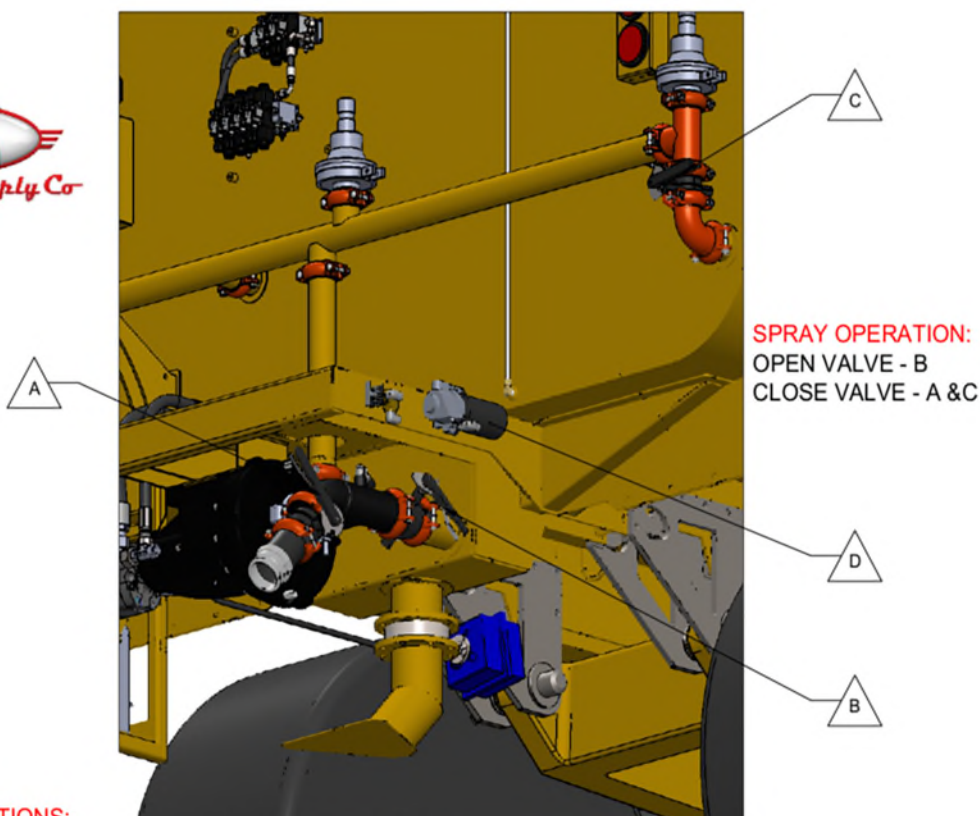

SPRAY OPERATION:
OPEN VALVE - B
CLOSE VALVE - A & C

CREEK FILL OPERATIONS:

GO TO CREEK FILL LOCATION AT REAR OF TRUCK

STEP 1: ATTACH CREEK FILL HOSE TO INLET AT (A)

***A CLEAR HOSE IS RECOMMENDED TO VIEW IF ANY AIR BUBBLES ARE INSIDE**

STEP 2: SUBMERGE THE STRAINER END OF HOSE INTO WATER

***A FOOT VALVE IS RECOMMENDED TO BE ATTACHED TO THE HOSE**

STEP 3: CLOSE VALVE (B) & (C)

STEP 4: ACTIVATE THE HALE PRIMER (D) BY PULLING THE HANDLE OUT UNTIL NO AIR IS IN THE WATER DISCHARGED FROM THE PRIMER PUMP.

STEP 5: ACTIVATE THE WATER PUMP TO BUILD PRESSURE TO THE TANK

STEP 6: OPEN VALVE (C) 1/4 OF THE WAY, THEN WHEN PUMP STARTS FILLING THE TANK OPEN IT COMPLETELY.

IF WATER DOES NOT BEGIN FILLING THE TANK WITHIN 2 MINUTES, SHUT OFF THE WATER PUMP AND REPEAT STEPS 4-6 UNTIL SUCCESSFUL



DISPENSE OPERATIONS

TOUCHPAD CONTROLLER OPERATION



There are (2) output screens standard on the Curry Supply touchpad. On the bottom right of the touchpad is an button labeled "AUX 1". By pushing this button, the screens are switched to show all the outputs. A (0) represents the "OFF" position, while a (1) represents "ON".



To turn on a feature, press the desired button once. A green indicator light will light up and the output number will change from a "0" to a "1".

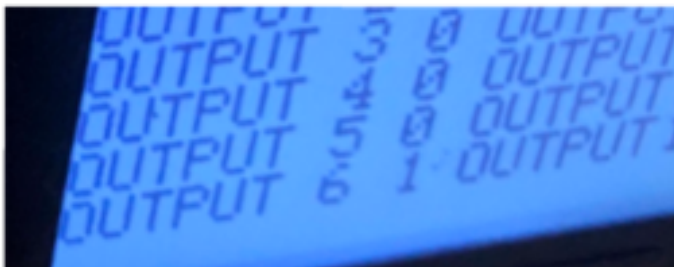

If equipped with a level indicator, the "AUX 1" button can be pressed twice to cycle to the level indicator screen. The level indicator shows the water level inside of the tank.

NOTE

THIS IS PRE-PROGRAMMED INTO THE SYSTEM PRIOR TO SHIPPING. IF A LEVEL KIT IS ORDERED AFTER PURCHASING A TANK, CONTACT CURRY SUPPLY FOR CONTROL SET UP.

MOBILE OPERATIONS

CAUTION

TRUCK ENGINE MUST BE AT IDLE SPEED WHEN ACTIVATING OR DEACTIVATING THE WATER PUMP. FAILURE TO DO SO MAY CAUSE PERMANENT WATER PUMP DAMAGE AND VOID WARRANTY.

NOTE

CHECK THE WATER LEVEL BEFORE OPERATION WITH THE TRUCK IN PARK.

1. With the truck in park and the parking brake engaged, start the engine.
2. OPEN a spray head by pressing the button, or moving the slide switch, to the OPEN position.



3. Turn ON the "WATER PUMP"



4. Put the truck in gear/drive and pull forward.
5. Water will begin to spray from the selected spray head as RPM's rise.

CAUTION

DO NOT EXCEED THE RECOMMENDED RPMs
LABELED ON THE DASH.

NOTE

IF THERE IS NO RPM LIMIT DISPLAYED ON
THE DASH, CALL CURRY SUPPLY BEFORE
OPERATING.

SWITCHING SPRAY HEADS

1. Following the previous steps, with current spray head still OPEN, OPEN a newly desired spray head at the SAME TIME.

CAUTION

AT LEAST ONE SPRAY HEAD SHOULD BE
OPEN WHILE THE WATER PUMP IS ON.

NOTE

MULTIPLE SPRAY HEADS CAN BE OPEN
SIMULTANEOUSLY. HOWEVER, OPERATING
MORE THAN 2 AT THE SAME TIME WILL
DRASTICALLY REDUCE WATER PRESSURE.



2. Once finished with previous spray head, CLOSE it, while leaving the new spray head OPEN.

CLOSING SPRAY HEADS

1. When spray operation is completed, the spray heads will need to be CLOSED.
2. Slow the vehicle to under 1000 RPMs.
3. While a spray head is still OPEN, turn OFF the "WATER PUMP".
4. CLOSE the spray heads that are open.

WATER CANNON (if installed)

If installed, the "Water Cannon" is activated the same way that a spray head is. It can be used while mobile or stationary.

1. While the vehicle is below 1000 RPMs, OPEN the "WATER CANNON" spray head on the touchpad. 
2. Turn ON the "CANNON POWER" button to enable operation of the cannon joystick. 
3. Turn ON the "WATER PUMP" on the touchpad.
4. Raise the RPMs by either driving forward or by using cruise control buttons. Water will begin to spray from the water cannon.
5. The direction of the stream is controlled by the joystick inside the cab.
6. The spray width can be changed by using the thumb button, opening or closing the cannon nozzle.



7. When spraying is complete, turn OFF the Water Pump
8. Turn OFF "CANNON POWER"
9. Turn OFF "WATER CANNON"

WATER HOSE / HOSE REEL

The hose reel may be shipped in a stowed position (see diagram below (B)). Using a lifting device (crane, fork truck, etc.) secure a chain to the reel platform, and to the lifting device. Once the platform is secure, remove the bolts holding the reel platform in Plate (A), and lower the platform into the operating position (D). With the reel in operating position, insert the bolts from (A) into the (C) location to secure the reel platform. Connect the hose from the reel to the rear spray bar (E) before using.

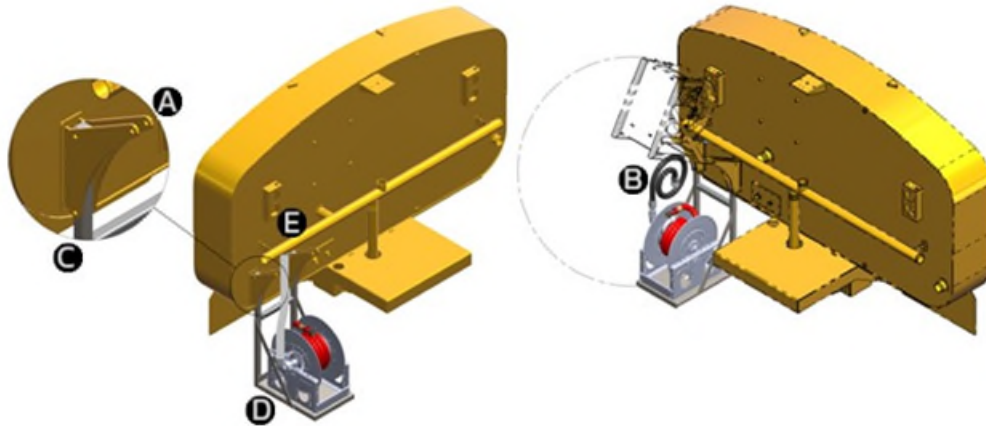

1. With the truck in park, and the parking brake engaged, start the engine.
2. Turn ON the "HOSE REEL" valve on the touch pad. 
3. Turn ON the "Water Pump"
4. At the rear of the truck, ensure the hose is secured to the spray bar.
5. Ensure the hose nozzle is CLOSED (head rotates to OPEN and CLOSE).
6. OPEN the ball valve (A) above the reel to allow water to fill the hose.
7. Unlock the hose reel by pulling the spring loaded locking pin (C) and unravel the hose to desired length.
8. Rotate the hose nozzle to OPEN the hose. The spray can be adjusted by opening it more or less.
9. When spraying is complete:, CLOSE the hose nozzle.
10. CLOSE the ball valve to the spray bar
11. Reel in the hose using the crank (B)
12. Lock the hose reel (C).
13. Turn OFF the Water Pump on the touchpad.
14. Turn OFF the Hose Reel Valve.

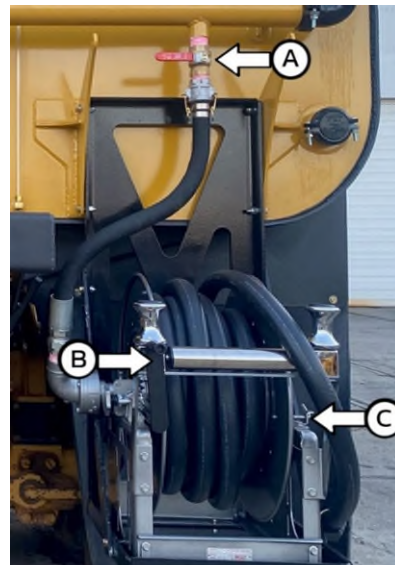

SPRING REWIND HOSE REEL

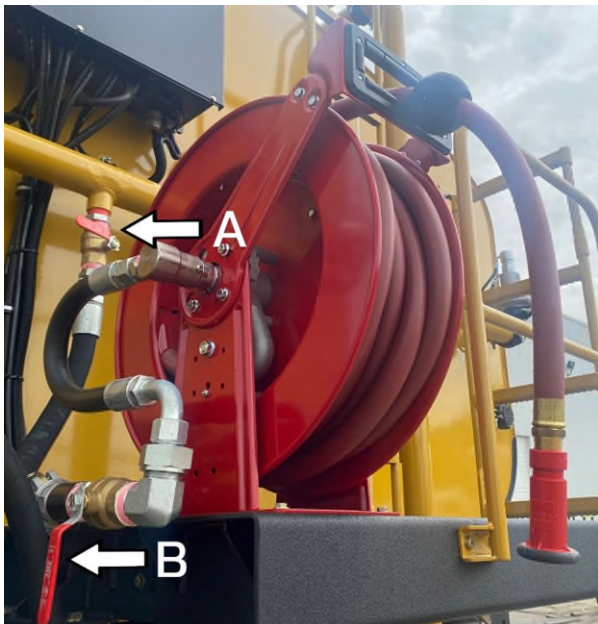

10. CLOSE the A & B valves to the spray bar.
11. Pull out slightly on the hose to unlock the reel and engage the spring rewind in the reel.
12. Slowly allow the reel to rewind the hose back onto it.
13. Turn OFF the Water Pump on the touchpad.
14. Turn OFF the Hose Reel Valve on the touchpad.

1. With the truck in park, and the parking brake engaged, start the engine.
2. Turn ON the "HOSE REEL" valve on the touch pad.
3. Turn ON the "Water Pump"
4. At the rear of the truck, ensure the hose is secured to the spray bar.
5. Ensure the hose nozzle is CLOSED (head rotates to OPEN and CLOSE).
6. OPEN the ball valve (A) and (B) to allow water to fill the hose.
7. Pull the hose from the reel to the desired length. A spring locking system will hold the hose at that length.
8. Rotate the hose nozzle to OPEN the hose. The spray can be adjusted by opening it more or less.
9. When spraying is complete:, CLOSE the hose nozzle.



DRAINING OPERATIONS

DUMP VALVE / TANK DRAIN



The Gravity Dump is the primary method to drain the tank completely. To activate the dump valve, press the dump valve button on the touchpad.



NOTE

THE GRAVITY DUMP DOES NOT NEED THE WATER PUMP TO BE ON FOR OPERATION.

In the event that there is no power, the dump valve can be activated manually by pushing in and rotating the black knob. Rotating the knob counter clockwise will open the valve, and rotating it clockwise will close it.

CAUTION

DO NOT MANUALLY OPEN THE DUMP VALVE UNLESS THERE IS NO POWER AT TOUCHPAD.

CAUTION

DO NOT OPERATE THE MANUAL OVERRIDE WHEN THE ACTUATOR IS TURNING



SECTION 4

Maintenance & Lubrication

Due to the numerous jobs and purposes, varying environments and climates, and importance to safety, routine maintenance is highly recommended. Regular maintenance keeps the water trucks functioning correctly and at optimum efficiency. The following tasks can help prevent breakdown and keep the truck on the job when you need it most.

NOTE

FOR THE MOST ACCURATE MAINTENANCE FOR A SPECIFIC CHASSIS SYSTEM, REFER TO THE PRODUCT SPECIFIC USER MANUAL

DAILY SAFETY MAINTENANCE

Tires – Check for proper inflation and tread depth.

Brake System – Routine inspections on brake pads and calipers for safe operation.

Lights – Check all lights are working and functioning correctly.

Fluids – Check engine oil, coolant, hydraulic fluid, and wiper fluid are at proper levels.

Hoses – Check for leaks, cracks, and that they are fully secure.

CAUTION

WITHIN THE FIRST WEEK OF OWNING, CHECK THE TORQUE ON THE BOLTS OF WATER PUMP

WATER PUMP ROUTINE MAINTENANCE

A well-maintained pumping system will extend the life of the unit and require fewer repairs. This means less down time, which could be extremely critical when a constant delivery of liquid is required. A routine maintenance and inspection schedule should be set up on a weekly, quarterly, and annual basis with records kept of these actions.

The following is a breakdown list of maintenance that is recommended to be completed:

WATER PUMP DIAGRAM

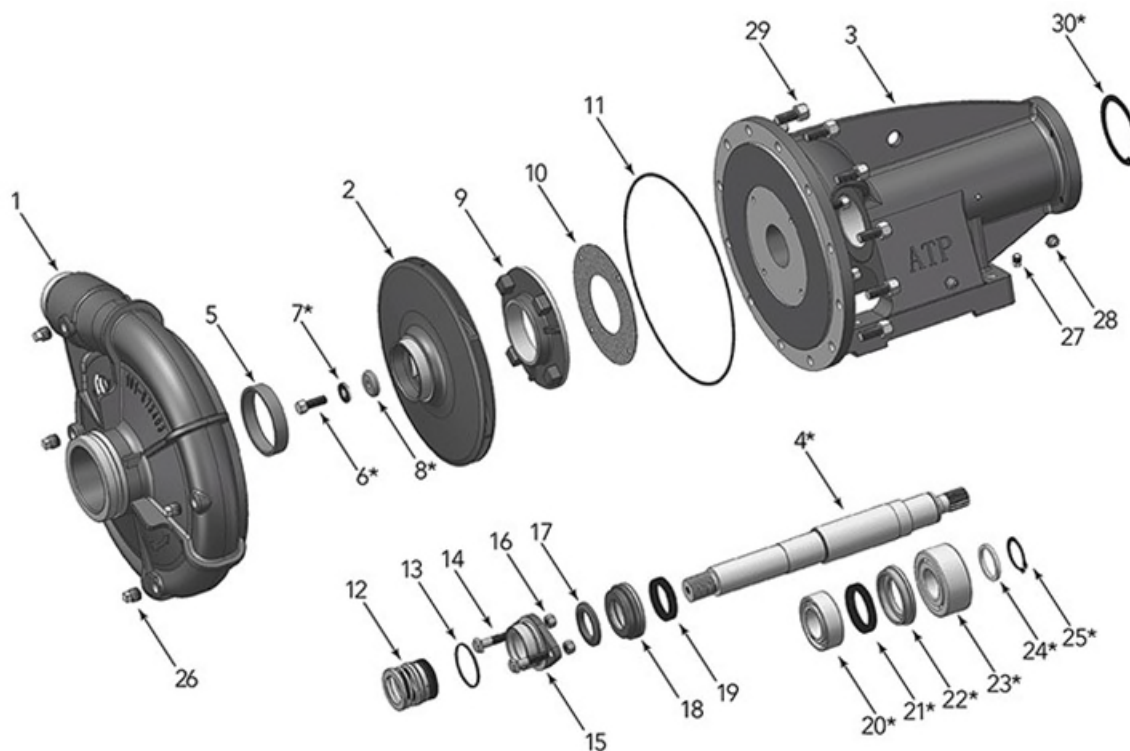

- | | |
|----------------------------|-------------------------|
| 1. Volute | 16. Hex Nut |
| 2. Impeller | 17. Water Slinger |
| 3. Hydraulic Bearing Frame | 18. Inner bearing Cap |
| 4. Splined Shaft Kit | 19. Oil Seal |
| 5. Wearing Ring | 20. Ball Bearing |
| 6. Cap Screw | 21. Oil Seal |
| 7. Lock Washer | 22. Outer Bearing Cap |
| 8. Impeller Washer | 23. Ball Bearing |
| 9. Balance Ring | 24. Shaft Thrust Ring |
| 10. Balance Ring Gasket | 25. Pump Retaining Ring |
| 11. Volute Gasket | 26. 1/2" Pipe Plug |
| 12. Mechanical pump Seal | 27. 1/4" Pipe Plug |
| 13. O Ring | 28. Grease Fitting |
| 14. Gland bolt | 29. Hex Cap Screw |
| 15. Shaft Seal Retainer | 30. Retaining Ring |

WEEKLY MAINTENANCE (~250 miles)

Vibration: All rotating machines can be expected to produce some vibration. However, excessive vibration can reduce the life of the unit. If the vibration seems excessive, discontinue operation, determine the cause, and correct the issue.

Noise: When the unit is operating under load, listen closely for unusual sounds that might indicate the unit is in distress. Determine the cause and correct the issue.

Operating Temperature: During operation, heat is dissipated from the pump bearings and the driver. After a brief period of time, the surface of the pump bracket will be quite warm (as high as 150° degrees F), which is normal. If the surface temperature of the pump bracket or driver is excessive, discontinue operation, determine the cause of the temperature rise, and correct the issue. Bearings will run hotter for a brief run-in period after packing which is normal. However, worn bearings will cause excessive temperatures and need to be replaced. The pump unit is cooled by the water following through it and will normally be at the temperature of the pumping liquid.

Rope Packing: After a brief period of operation, verify that the stuffing box area and gland are not hot. If heating is detected, loosen the gland nuts evenly until water is just running out of stuffing box in a DROPLET form. Water must not be streaming or spraying out (water drops should be 40–60 drops a minute). Verify cool operation periodically. Adjust gland nuts **EVENLY** as necessary for lubrication and cooling of the packing. If packing has been tightened to the limit of the packing gland travel, additional packing is necessary.

CAUTION

IF THE UNIT IS EQUIPPED WITH A ROPE SEAL WATER PUMP THAT REQUIRES A MINIMUM DRIP.
DO NOT OVER TIGHTEN THE SEAL. MECHANICAL SEALS WILL NOT DRIP

Mechanical Seal: Inspect seal for leakage. There should be no leakage from mechanical seal.

Suction Line: Inspect line and screen for flow obstruction.

QUARTERLY (~3,000 miles)

Pump and Piping Connections: Inspect all system piping connections for leakage or misalignment. Misalignment of pipe connections to the pump will put excessive strain on the pump case and can cause damage to internal components of both the pump and motor. If stress on the pump case is suspected, adjust pipe supports to correct. For flange connections, misalignment can be checked by shutting down the pump, and removing the pipe flange bolts on the pump connections. If the mating flanges come apart or shift, there is pressure at the connection(s) and adjustments should be made to the piping supports until flanges mate without force. This procedure can be done throughout the piping system.

- Check pump foundation for soundness and see that all hold-down bolts are secure.
- Inspect packing or mechanical seal for possible replacement. Examine shaft sleeve, if present, for wear and replace it if necessary.
- Inspect pumping plant panel for signs of wear (i.e.: replace pitted contactors, etc., as needed).
- Check pump and/or motor bearings for signs of wear. Repack or replace as required.

ANNUALLY (~12,000 miles)

- Inspect the pump and entire pumping system for signs of wear.
- Inspect system valves and screens.
- Check electric motor windings for degradation, rewind if necessary.
- Inspect impeller, volute case, and seal chamber for signs or excessive wear or corrosion.
- Liquid End of pump requires no lubrication.
- Drain compressor to reduce condensation.

Wear rings, packing rings, and models using a mechanical shaft seal, are lubricated by the liquid being pumped.

CAUTION

DO NOT RUN DRY! LUBRICATION IS NEEDED TO AVOID DAMAGE.

BEARING FRAME: Add approximately 2 ounces of a lithium based NGLI No. 2 extra pressure ball bearing grease to each bearing during quarterly inspection.

NOTE

GREASE FITTING IN PACKING AREA IS FOR PRIMING

HOSE REEL: Grease hose reel quarterly to avoid friction and rust build up.

WATER CANNON (If Installed)

The complete monitor and control system should be inspected during each apparatus check. Careful inspection for damage to the monitor and nozzle is especially important after each use.

Visually inspect each system component including the Monitor, Nozzle, Joystick, Valve and Wire Harnesses.

- Operate each function (left-right, up-down, jet-fog) from each control point.
- Flow water to check the nozzle pattern. If the pattern is disrupted, use the nozzle flush feature to clear the debris. To flush the nozzle, while spraying water from the cannon, open the spray pattern the full way, then close it to the tightest pattern, and repeat again. If the obstruction remains, remove the nozzle, and check for debris lodged between the nozzle stem and body.
- During nozzle flow test, inspect monitor swivel joints for leaks.
- Inspect all exposed wiring for signs of damage.

Drain water cannon after use by opening installed petcock valve. Stagnant water may cause rust, corrosion, or cracks when frozen.

WINTERIZING/FREEZE PREVENTION

Frozen water inside of the system can lead to considerable damage. To prevent damage please consider the following:

- Water Tank – Drain the water tank as much as possible, parking on an incline with the drain at the lowest point.
- Drain Valves – Open any drain valves installed on the spray system.
- Water Cannon – Open the drain valve on the cannon and open the nozzle to allow air flow.
- Hose – Remove hose reel supply hose and leave ball valve open. Open the hose nozzle and leave it open to drain.
- Fill Tube – Open valve to release any water that may be trapped.

SPARE PARTS

The number and type of spare parts kept on hand at any pump site is dictated by the severity of the service in which the pump is used. It is recommended that the following spare parts be kept on-site as a minimum back-up to service pump and reduce down-time. Parts shown do not apply to all models. Check your model/style when selecting spare parts.

- Mechanical shaft seal
- Packing set and packing hooks
- Shaft sleeve(s)
- Impeller wear ring
- All gaskets and O-Rings that are required for one entire pump assembly.
- Retaining rings
- Additional diaphragms for the air valves

If having a pump non-operational has severe consequences, a back-up pump should be considered. Otherwise, a backup impeller, volute case, bearings, and shaft, would be prudent.

LONG TERM STORAGE

If pump is to be out of service for an extended period, such as the winter months, the following storage procedures should be followed:

- Remove exterior dirt and grime or any substance that may trap moisture. Exposed metal is subject to oxidation, prime and repaint if necessary.
- Flush suction and discharge lines. Check for leaks and replace any worn gaskets.
- Remove the lowest plug in the pump, drain the pump casing, and suction and discharge lines.
- Lubricate the bearings.
- If possible, keep the unit clean and dry during storage period to guard against corrosion.
- Seal all open ports to keep out foreign objects such as insects, rodents, dust, and dirt.
- Rotate driver shaft periodically to prevent freeze-up of internal components.
- Shelter the pump from the elements when possible.

BOLT TORQUE SPECIFICATION CHART

Coarse Thread, Grade (8) Bolt Torque Specs

Normal Diameter	Clamp load (lbs)	Tightening Torque	
		Lubricated Threads	Dry Threads
1/4	2864	107 in-lbs	143 in-lbs
5/16	4719	221 in-lbs	295 in-lbs
3/8	6974	33 ft-lbs	44 ft-lbs
7/16	9568	52 ft-lbs	70 ft-lbs
1/2	12771	80 ft-lbs	106 ft-lbs
9/16	16375	115 ft-lbs	154 ft-lbs
5/8	20340	159 ft-lbs	212 ft-lbs
3/4	30101	282 ft-lbs	376 ft-lbs
7/8	41556	455 ft-lbs	606 ft-lbs
1	54517	681 ft-lbs	909 ft-lbs
1 1/4	87220	1363 ft-lbs	1817 ft-lbs
1 3/8	103939	1768 ft-lbs	2382 ft-lbs
1 1/2	126473	2371 ft-lbs	3162 ft-lbs
Tie Down Spring Tension	5/8" Grade 8	5/8" of spring compression	

NOTE

ALL TORQUED BOLTS ARE TO BE MARKED AFTER BEING TIGHTENED TO SPECIFICATIONS.

CAUTION

ALL BOLTS SHOULD BE RECHECKED TO MEET TORQUE SPECS EVERY 500 MILES



Coarse Thread, Grade (5) Bolt Torque Specs

Normal Diameter	Clamp load (lbs)	Tightening Torque	
		Lubricated Threads	Dry Threads
1/4	2029	76 in-lbs	101 in-lbs
5/16	3342	157 in-lbs	209 in-lbs
3/8	4940	23 ft-lbs	31 ft-lbs
7/16	6777	37 ft-lbs	49 ft-lbs
1/2	9046	57 ft-lbs	75 ft-lbs
9/16	11599	82 ft-lbs	109 ft-lbs
5/8	14408	113 ft-lbs	150 ft-lbs
3/4	21322	200 ft-lbs	267 ft-lbs
7/8	29436	322 ft-lbs	429 ft-lbs
1	38616	483 ft-lbs	644 ft-lbs
1 1/4	53786	840 ft-lbs	1121 ft-lbs
1 3/8	64096	1102 ft-lbs	1469 ft-lbs
1 1/2	77991	1462 ft-lbs	1950 ft-lbs

NOTE

ALL TORQUED BOLTS ARE TO BE MARKED AFTER BEING TIGHTENED TO SPECIFICATIONS.

CAUTION

ALL BOLTS SHOULD BE RECHECKED TO MEET TORQUE SPECS EVERY 500 MILES



SECTION 5

Schematics

- [Hydraulic Box Open Picture](#) [Page 24](#)
- [Hydraulic Valve System](#) [Page 25](#)
- [Hydraulic Valve System 2 sides, 3 rear, 2 Front spray heads & Level Sensor](#) [Page 26](#)
- [Hydraulic Valve System 2 side, 3 rear, and Level Sensor](#) [Page 27](#)
- [2 Line Dump Cylinder Connections](#) [Page 28](#)
- [4 Line Dump Cylinder Connections](#) [Page 29](#)
- [Chassis Harness Connection Overview](#) [Page 30](#)
- [Wire Harness Diagram](#) [Page 31](#)
- [Wire Harness Diagram 2](#) [Page 32](#)
- [Rear Wiring ID Picture](#) [Page 33](#)
- [Hale Primer Wiring](#) [Page 34](#)
- [Elkhart Nitro Water Canon Layout](#) [Page 35](#)
- [Hydrema 24v Hoist Circuit Hydraulic Box](#) [Page 36](#)
- [Hitachi wiring diagram](#) [Page 37](#)
- [Hitachi hose connection diagram](#) [Page 38](#)

HYDRAULIC BOX OPEN VIEW

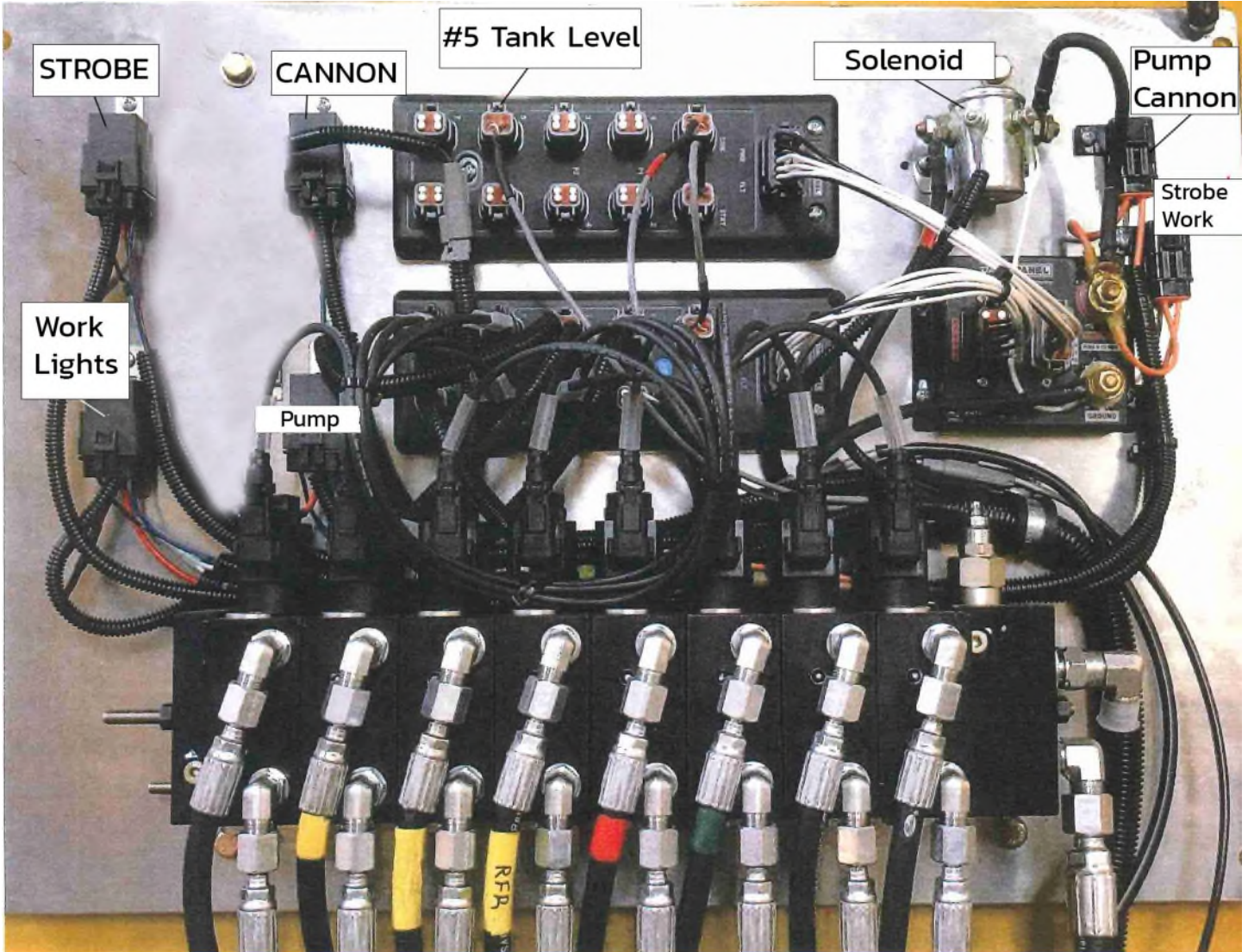

ITEM NO.	QTY.	PART NO.	STOCK DESC.
1	5	805314219	VALVE, SOLENOID, SV10-24-01-00-00-B-00
2	5	171149519	24V DE COIL, M16-24D-26W-DE
3	5	11189108	VALVE, CHECK, RPOC6-5-00 PO
4	5	92000619	PLUG, CAVITY, NCS060
5	5	11195193	MVB10-W-LH-6S
6	10	6801-4-6	FITTING, 1/4" JIC - 3/8" MOR, 90 DEG, STEEL
7	1	11187937	MVB10-E
8	1	1123610	INLET W/CAVITY FOR REDUCING VALVE
9	1	83020488	VALVE, REDUCING, PRMP PRMP 064-EN-1-00-35
10	1	DP-34044-5-100	OUTPUT BLOCK (COMPUTER)
11	1	DP-34044-1	INPUT/OUTPUT COMBO BLOCK
12	2	5400-8	FITTING, 1/2" MJ - 1/2" MB
13	1	6401-6-4	FITTING, 3/8" MB - 1/4" MP - STEEL
14	1	H2F2	FITTING, PLUG, 1/4" COUPLING - FP
15	1	DP-37055-2	2 CONNECTOR POWER SPLITTER
16	2	G25179-0808X	FITTING, 1/2" HOSE - 1/2" FJ SWIVEL, 90 DEG SHORT, STEEL
17	2	H41388541	RELAY, 24V, WATER PROOF, 10/20A
18	1	784623	FUSE HOLDER, IN-LINE, ATO/ATC
19	1	1594-3300	OFF ROAD HYD. VALVE BOX
20	10	G25170-0404X	SPRAY HEAD HOSE CONNECTIONS
20	20	4857-0120	FITTING, 1/4" HOSE - 1/4" FJ SWIVEL, STEEL
23	1	PST-DC20903-W	HOSE, 1/4", HYDRAULIC, MEDIUM PRESSURE CONVERTER, 12/24V - 9V DC
24	2	52MU8	SOCKET, WATER PROOF RELAY, WITH LEADS

ITEMS NOT SHOWN			
QTY.	PART NO.	STOCK DESC.	NOTES
1	DP-33026-3-002	KEYPAD/DISPLAY, 24V DC	LOCATED ON THE BACK OF THE CONTROL PAD.
1	DP-34042-402	TERMINAL RESISTOR	
2	M-D185-XDBKIT	18 PIN CONNECTOR KIT	
1	DP-38022-400	PST-2 CONNECTOR KIT	
1	RAM-202U	RAM MOUNT, 2.5" BASE	
1	RAM-107BU	RAM MOUNT, 1.5" RUGGED BASE	
1	RAM-201U	RAM MOUNT, DOUBLE SOCKET ARM	
1	7072-77501-7540060	PVAS ASSEMBLY KIT	ROD CONNECTOR KIT PART NUMBERS DIFFER BASED ON THE AMOUNT OF VALVES USED.
3		Y-CABLE, 2' LENGTH	

COMBO OUTPUT BLOCK IS USED WITH A TANK FILL INDICATOR. WHEN A TANK IS EQUIPPED WITH A DIGITAL LEVEL INDICATOR, TOGGLE THE BOTTOM RIGHT BUTTON ON THE CONTROL PANEL BRINGS UP THE FILL DISPLAY ON THE CONTROLLER IN THE CAB.

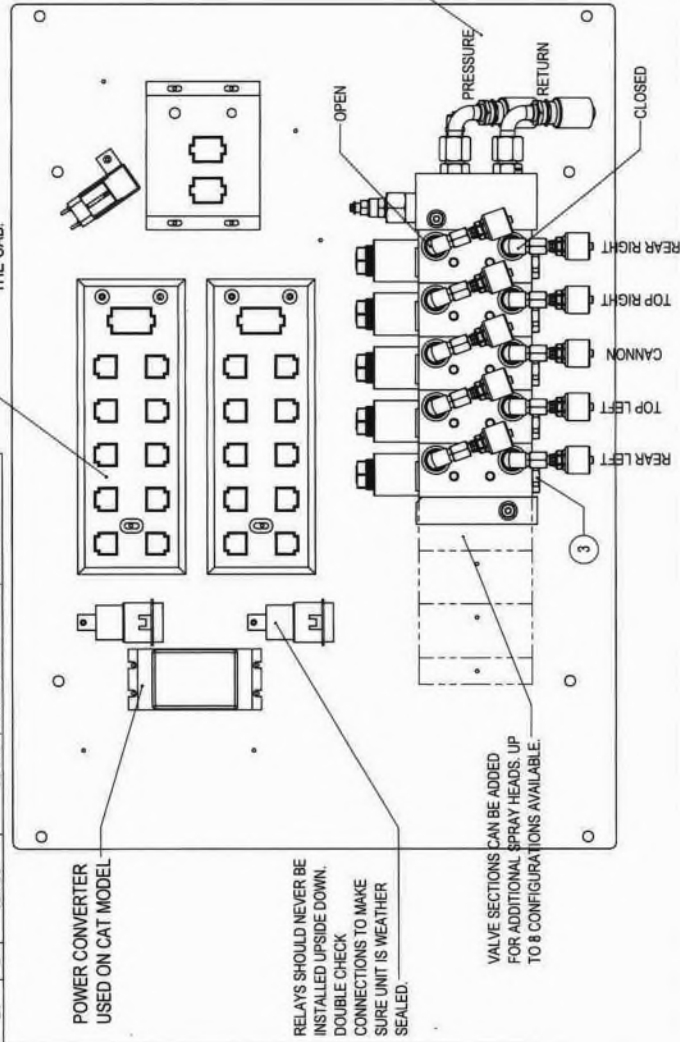

ITEMS 1,2,3,4,5,6, 7, & 8 ARE TIED TO THE SPRAY HEAD COUNT. THIS ASSEMBLY MAKES UP THE CONTROL SYSTEM FOR (1) SPRAY HEAD UNIT.

OPEN CIRCUIT ALLOWS THE SPRAY HEAD TO BE OPEN AND PUSH WATER. CLOSED CIRCUIT HOLDS HYDRAULIC PRESSURE TO KEEP THE SPRAY HEAD CLOSED. CHECK VALVE (3) KEEPS THE SYSTEM PRESSURE FROM BLEEDING OFF WHEN VALVE IS CLOSED.

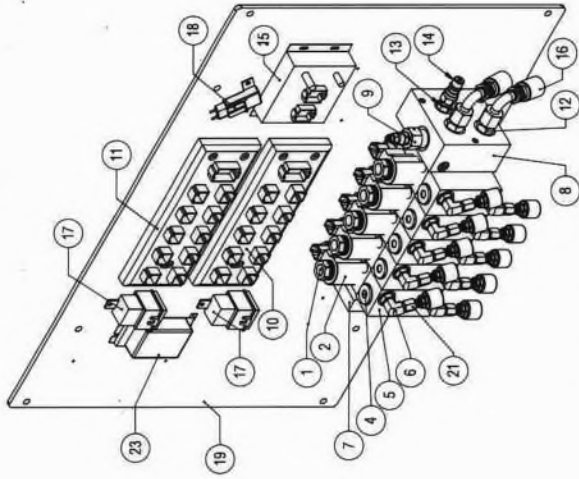



Curry Supply Co.

PART NO.	1634-7800	DATE	10/02/20
TOLERANCES:	UNLESS OTHERWISE SPECIFIED:	NAME	MLC
	FRACTIONAL: ± 1/8"	MODEL BY:	MLC
	ANGULAR: ± 1°	DRAWN BY:	MLC
	TWO PLACE DECIMAL: ± 0.01"	MATERIAL	ASM
	THREE PLACE DECIMAL: ± 0.005"	PROCESS	A
		THICKNESS	
PROPRIETARY AND CONFIDENTIAL		UNITS	In
THIS DRAWING IS THE SOLE PROPERTY OF CURRY SUPPLY COMPANY. ANY REPRODUCTION IN PART OR AS A WHOLE WITHOUT THE WRITTEN PERMISSION OF CURRY SUPPLY COMPANY IS PROHIBITED.		DO NOT SCALE DRAWING	
TITLE:	HYDRAULIC VALVE SYSTEM, OFF ROAD WATER, 5 VALVE	SIZE	B
DRAWING NO.	1634-7800	REV	0
WEIGHT:			

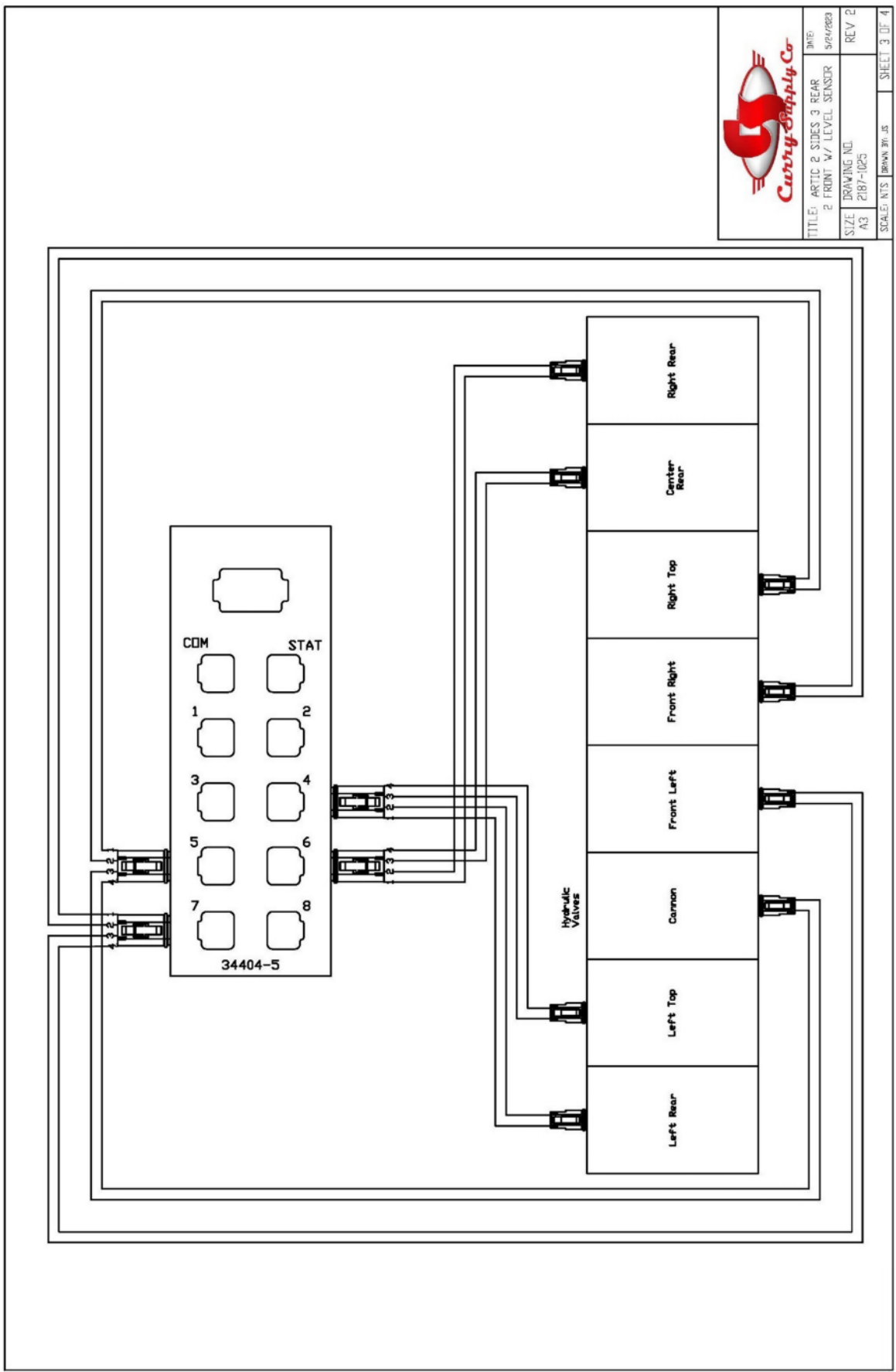

TITLE: ARTIC 2 SIDES 3 REAR 2 FRONT W/ LEVEL SENSOR	DATE: 9/17/2023
SIZE: DRAWING NO. A3 2187-1025	REV: 2
SCALE: NTS	DRAWN BY: JS
SHEET 3 OF 4	





TITLE: ARTIC 2 SIDES 3 REAR W/ LEVEL SENSOR		DATE: 5/24/2023
SIZE A3	DRAWING NO. 2187-1025	REV 2
SCALE: NTS	DRAWN BY: JS	SHEET 2 OF 4

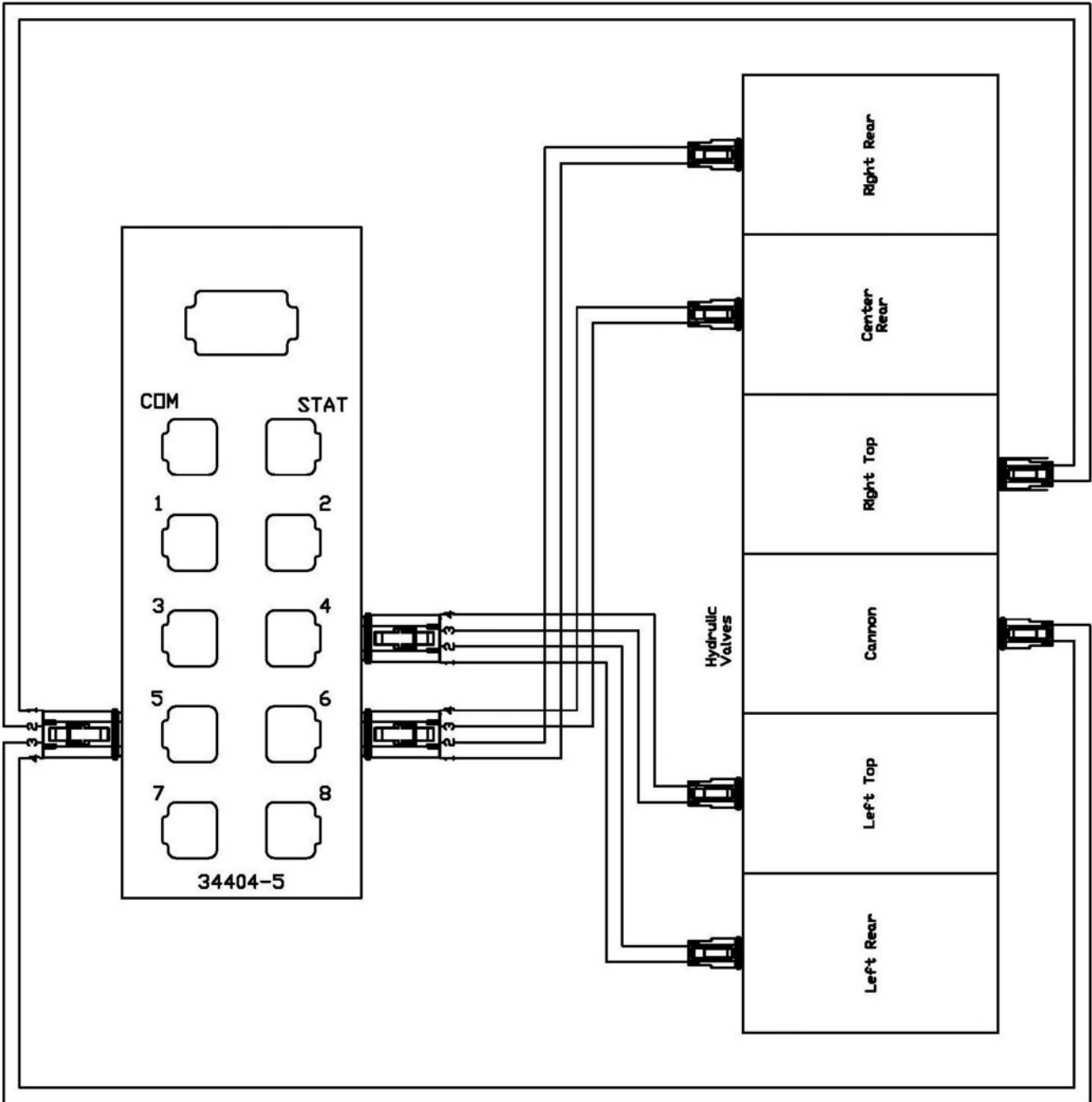

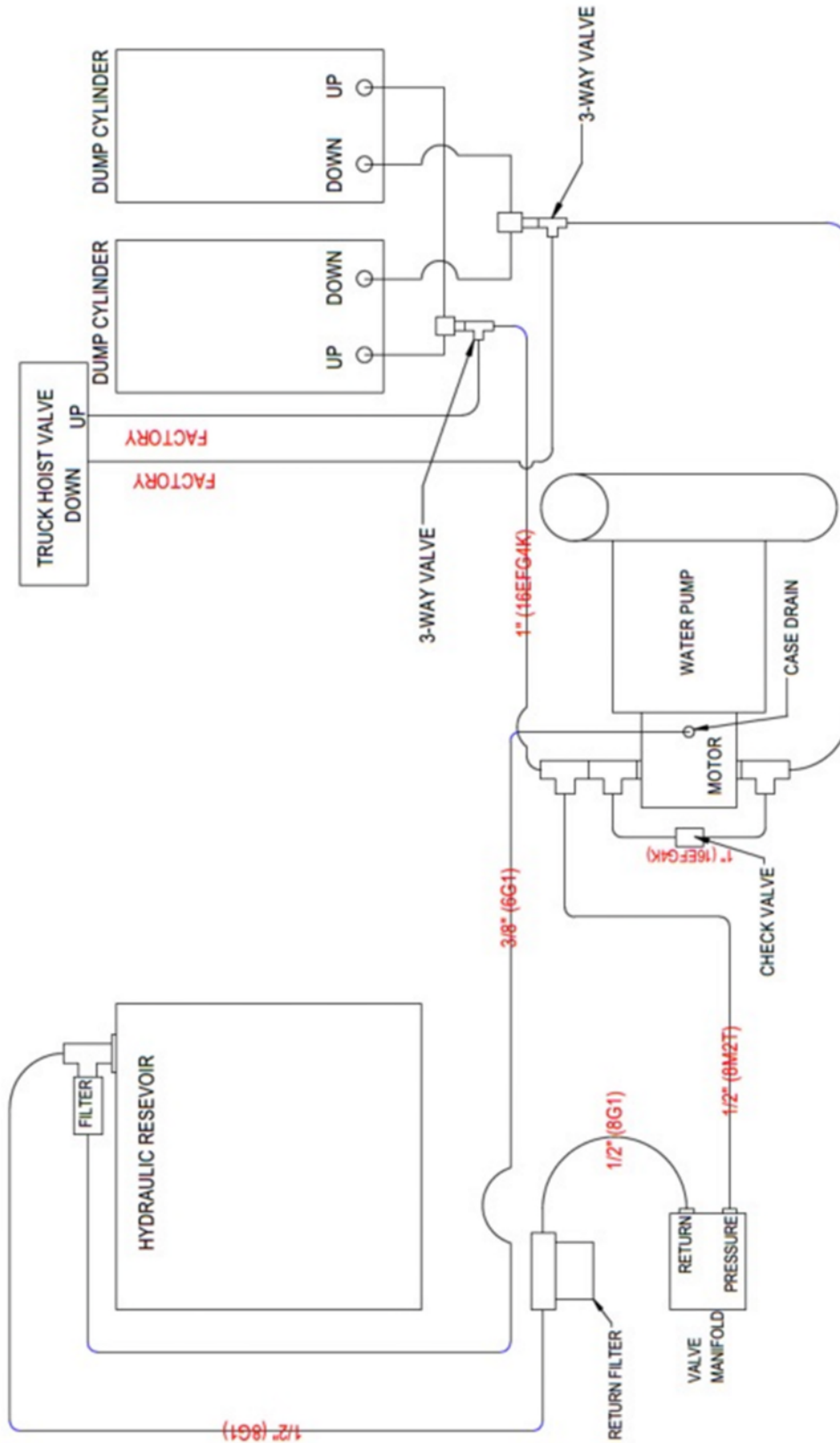

Curry Supply Co. TITLE: 2-LINE DUMP CYLINDER CONNECTIONS		NAME	DATE	MODEL BY:	DATE	SIZE	PART NO.	REV
		MILC	3/22/17	MILC		A	1630-1100	
UNLESS OTHERWISE SPECIFIED: DIMENSIONS ARE IN INCHES TOLERANCES: FRACTIONAL ± 1/8" ANGULAR: MACH ± 1° TWO PLACE DECIMAL ± 0.01 THREE PLACE DECIMAL ± 0.005 ALL TOLERANCES ARE ± 1/8" UNLESS NOTED. MATERIAL PROCESS		JOB NUMBER DRAWING NO. QUANTITY CUSTOMER DESIGN STATUS THICKNESS UNITS	COMMENTS: NO MODEL - DRAWING ONLY	DO NOT SCALE DRAWING		SHEET 2 OF 2		
PROPRIETARY AND CONFIDENTIAL THE INFORMATION CONTAINED IN THIS DRAWING IS THE SOLE PROPERTY OF CURRY SUPPLY COMPANY. ANY REPRODUCTION IN PART OR AS A WHOLE WITHOUT THE WRITTEN PERMISSION OF CURRY SUPPLY COMPANY IS PROHIBITED.								



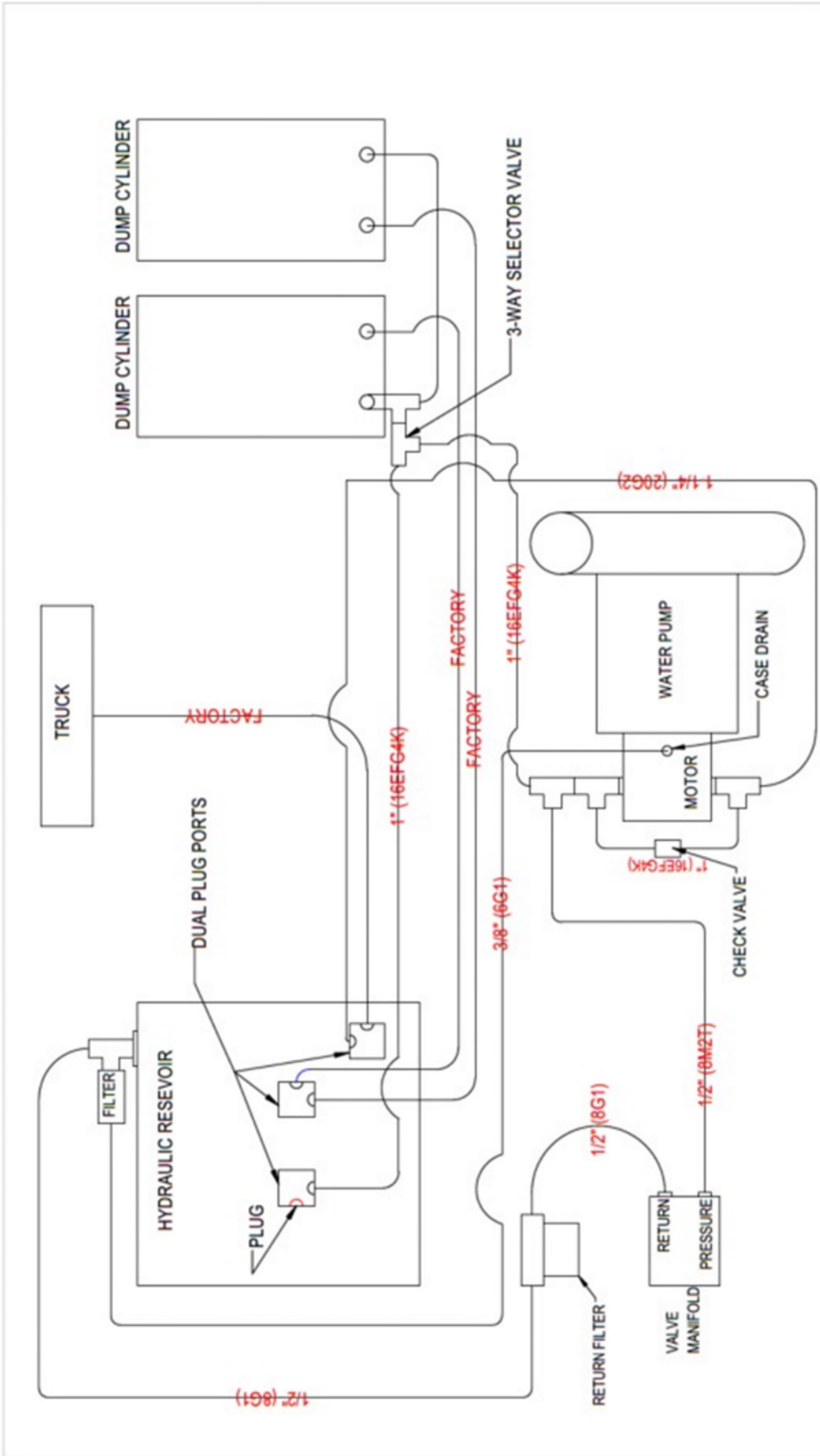

Curry Supply Co.		NAME: MLC DATE: 3/22/17	MODEL BY: DRAWN BY: ENG APPR: MFG APPR:	SIZE: A PART NO.: 1630-1000 REV:
TITLE: 4-LINE DUMP CYLINDER CONNECTIONS		COMMENTS: NO MODEL - DRAWING ONLY		
UNLESS OTHERWISE SPECIFIED: DIMENSIONS ARE IN INCHES TOLERANCES: FRACTIONAL: $\pm 1/8"$ ANGULAR: MACH: \pm BEND: $\pm 1"$ TWO PLACE DECIMAL: ± 0.01 THREE PLACE DECIMAL: ± 0.005 ALL TOLERANCES ARE $\pm 1/8"$ UNLESS NOTED. MATERIAL: PROCESS:		DO NOT SCALE DRAWING		
JOB NUMBER: DRAWING NO.: QUANTITY: CUSTOMER: DESIGN STATUS: THICKNESS: UNITS:	APPLICATION:			
PROPRIETARY AND CONFIDENTIAL THE INFORMATION CONTAINED IN THIS DRAWING IS THE SOLE PROPERTY OF CURRY SUPPLY COMPANY. ANY REPRODUCTION IN PART OR AS A WHOLE WITHOUT THE WRITTEN PERMISSION OF CURRY SUPPLY COMPANY IS PROHIBITED.				



800.345.2829

www.CurrySupply.com



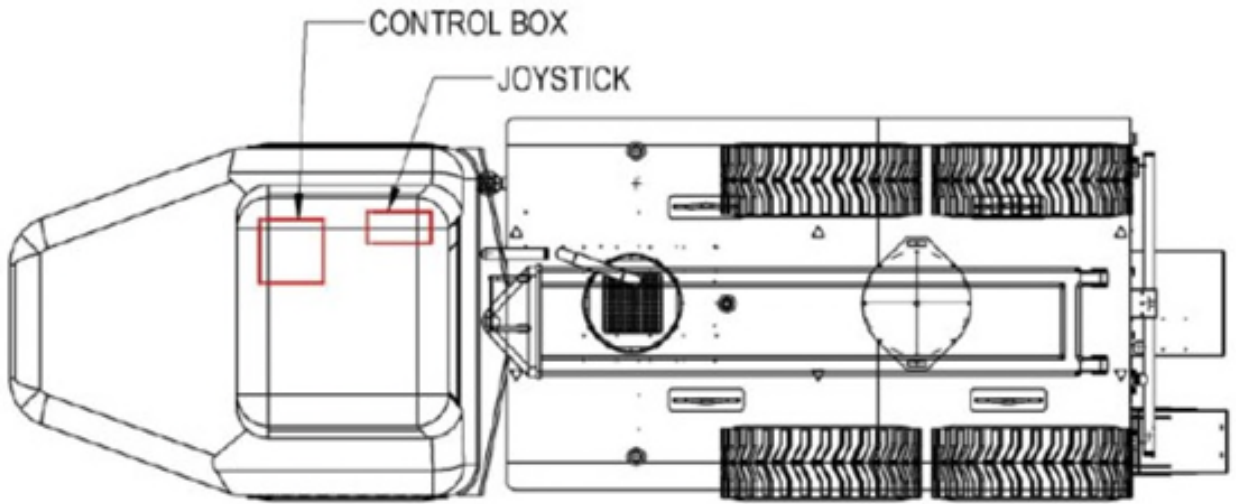

Drawing for Reference

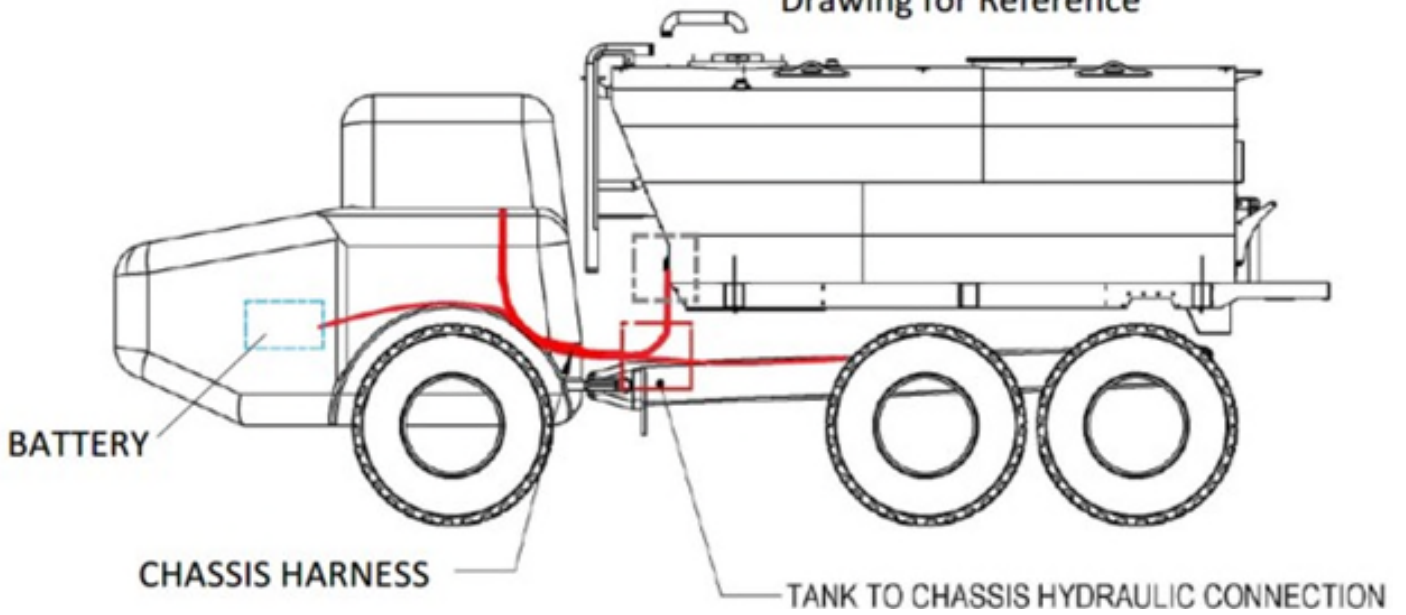

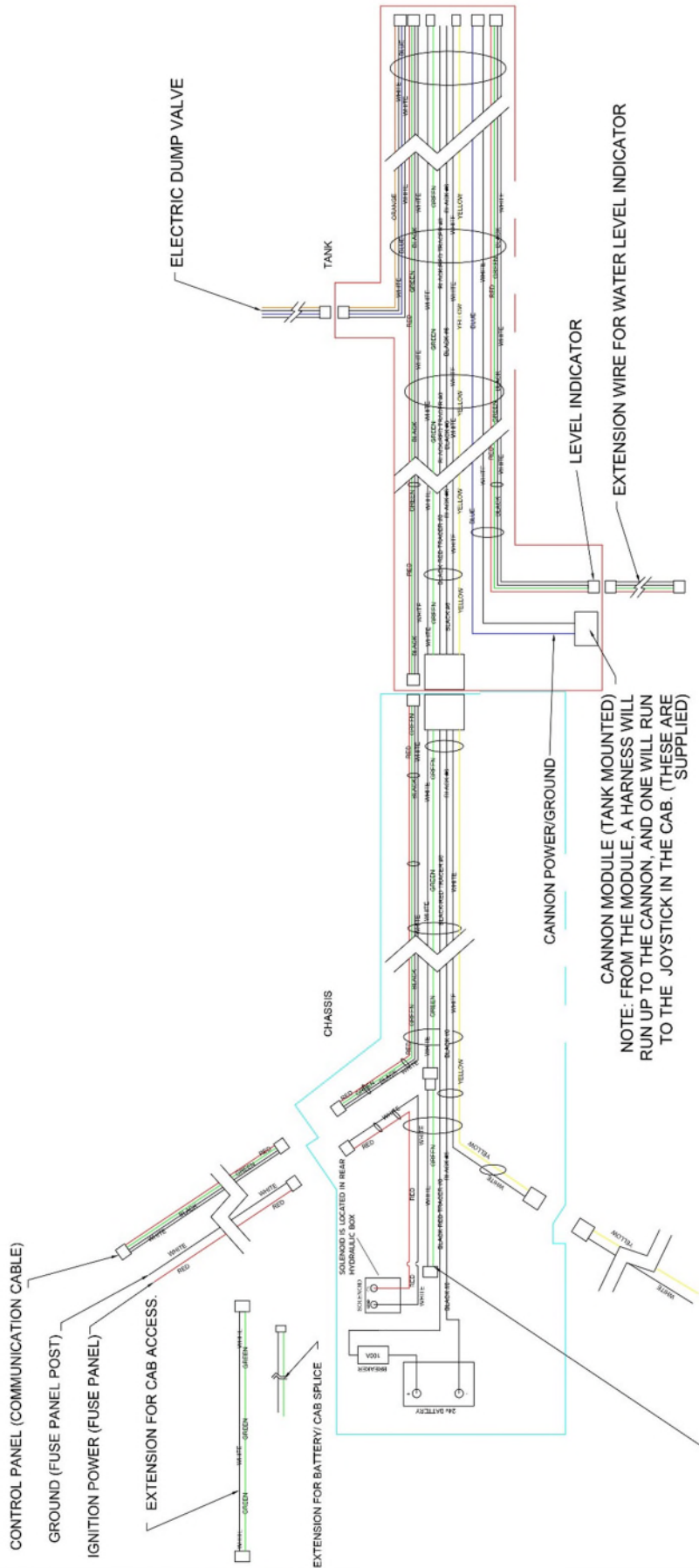

NOTE:
 GREEN/WHITE WIRE IS PRIMARILY USED FOR VOLVO 12V POWER TO HOIST. POWER IS PULLED FROM 12V SIDE OF BATTERIES OR (USING THE EXTENSION) THE CAB. ON ADDITIONAL MODELS, WIRES MAY BE USED FOR STANDARD INSTALLS REQUIRING GENERAL POWER (WIRE SPEC. 14GA)

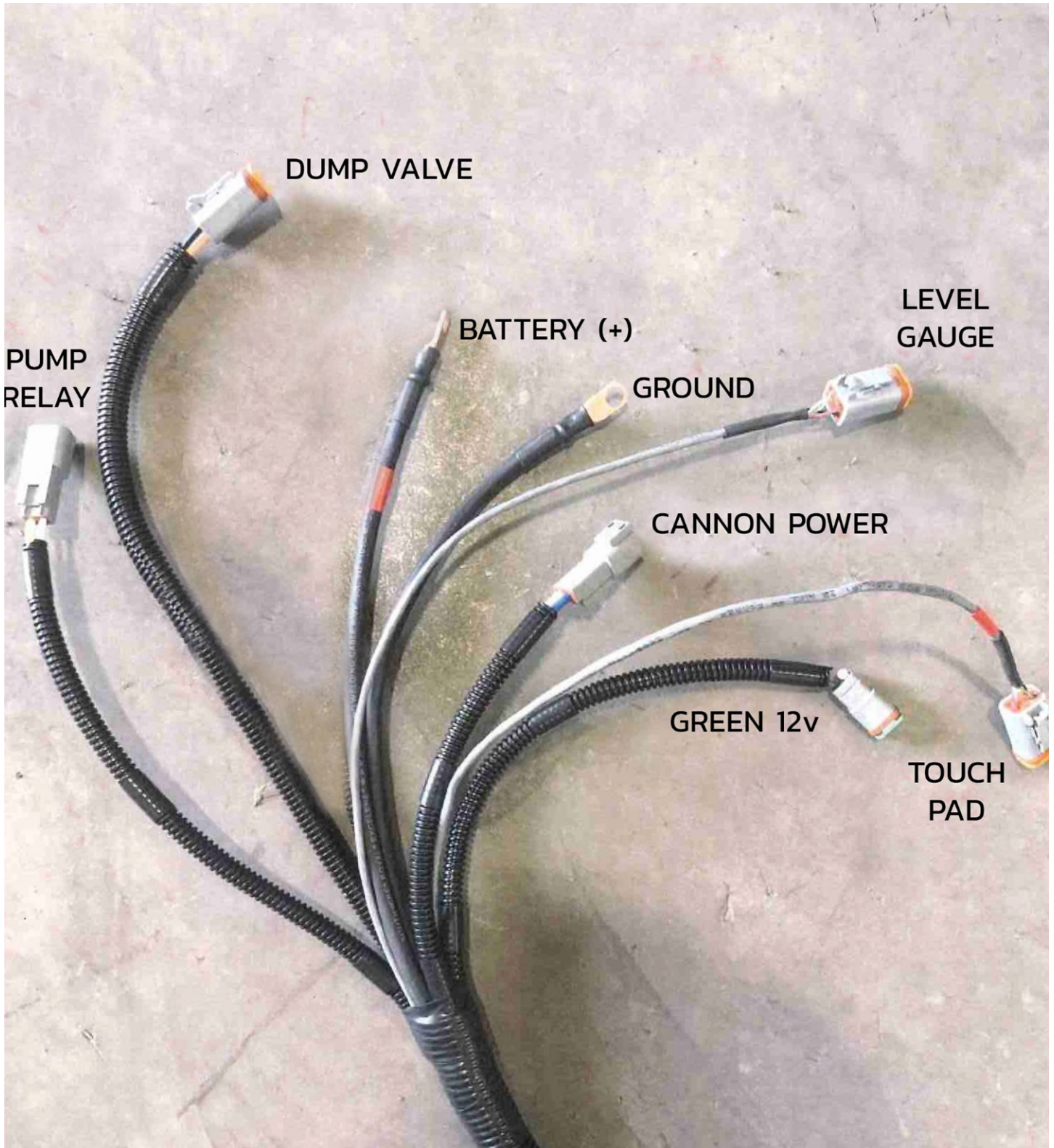

NOTE:
 4AWG MUST BE RATED
 HIGHER THAN THE
 CIRCUIT BREAKER
 USED

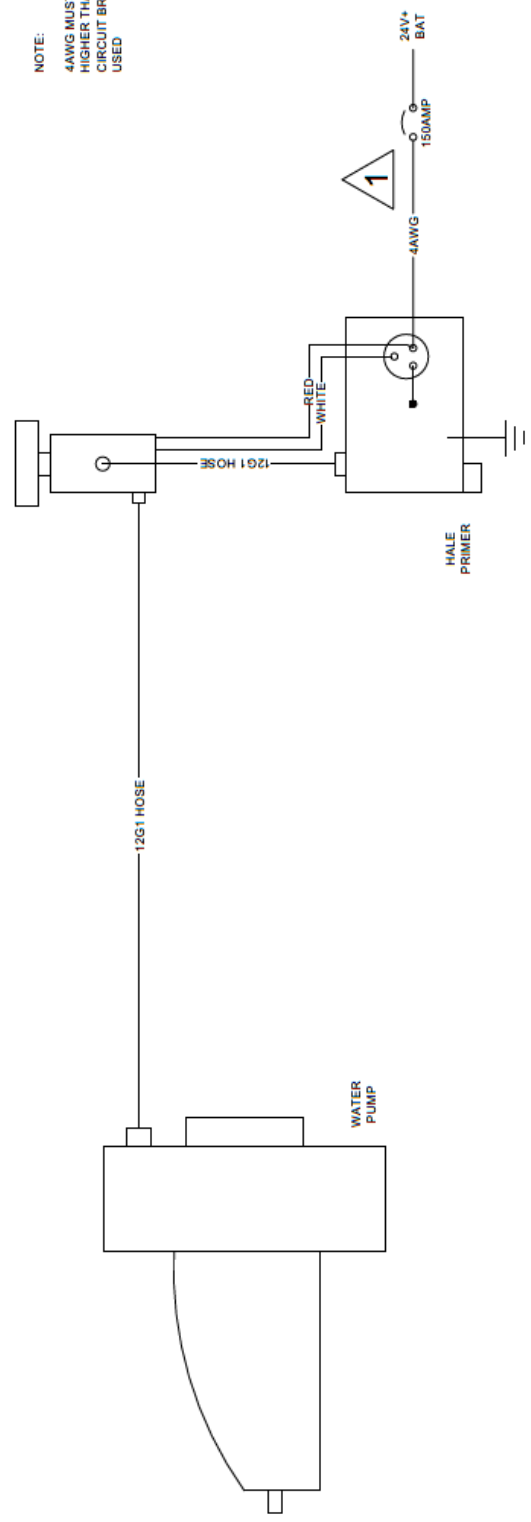

TITLE: HALE PRIMER INSTALL HYDREMA	DWG: 5/6/24
SIZE: DRAWING NO. 2387-1030	REV: 1
SCALE: NTS	DRAWN BY: JS
SHEET 2 OF 2	



NOTES:
DRAWING NOT TO SCALE.
FOR REFERENCE ONLY.

NITRO HD JOYSTICK
P/N 41067000

OPTIONAL: EXTEND LENGTH BETWEEN
MODULE AND JOYSTICK UP TO 75
FEET BY ADDING UP TO 5 EXTENSION
HARNESSES, P/N 37527000 HERE.

OPTIONAL: REMOVE JOYSTICK
FROM ENCLOSURE AND
USE AS PANEL MOUNT

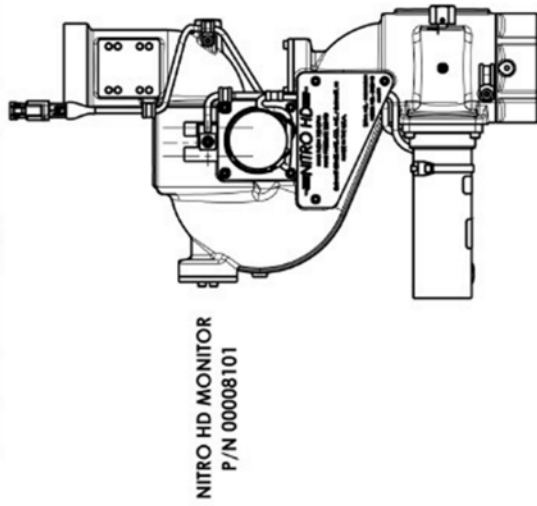

NITRO HD MONITOR
P/N 00008101

NITRO HD MODULE
P/N 81824001

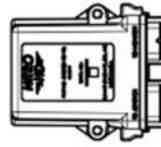

MODULE TO JOYSTICK HARNESS
P/N 37523000

MODULE TO MONITOR HARNESS
P/N 37522000

15' HARNESS SUPPLIED
BY ELKHART BRASS

POWER & GROUND LEADS
TO BE CONNECTED BY CUSTOMER,
1' LENGTH, HEAT SHRINKABLE SPLICES

8' HARNESS SUPPLIED
BY ELKHART BRASS

NITRO HD LAYOUT DRAWING, KIT #1

REV: B	ZONE: C7, C8	DESCRIPTION: ADDRESS AND JOYSTICK EXTENSION HARNESS 37527000 BEING USED BETWEEN THE JOYSTICK AND MODULE	BY: KAP	ECN NUMBER: 170512
DATE: 12/01/2016	DRAWN BY: KAP	ELKHART BRASS MFG. CO., INC. #1302 West Beersberry Ave, Elkhart, IN 46514, USA We warrant our products to be free of defects in material and workmanship for a period of 12 months from the date of purchase. This warranty does not cover damage caused by misuse, neglect, or accidents. The user must be notified in writing within 30 days of the date of purchase. Copyright © 2012 by Elkhart Brass Mfg. Co., Inc.	DATE: 12/01/2016	DESCRIPTION: NITRO HD (KIT #1)
WEIGHT (LBS): 13.3	CHECKED BY:	MATERIAL: N/A	ASSEMBLY	SIZE: B
UNLESS OTHERWISE SPECIFIED DIMENSIONS ARE IN INCHES DO NOT SCALE PRINT	1 PLACE DEC.: ±.12'	TOLERANCE UNLESS OTHERWISE SPECIFIED	INTERPRET DIMENSIONS AND TOLERANCES PER ASME Y14.5M 1994	CATALOG NO.: 8100 HD
2 PLACE DEC.: REF	ANGLES: ±1°	CAD MODEL: 8100 HD	THIRD ANGLE PROJECTION	CAD SCALE: 1:1
			REV.:	B
			SHEET	1 OF 1

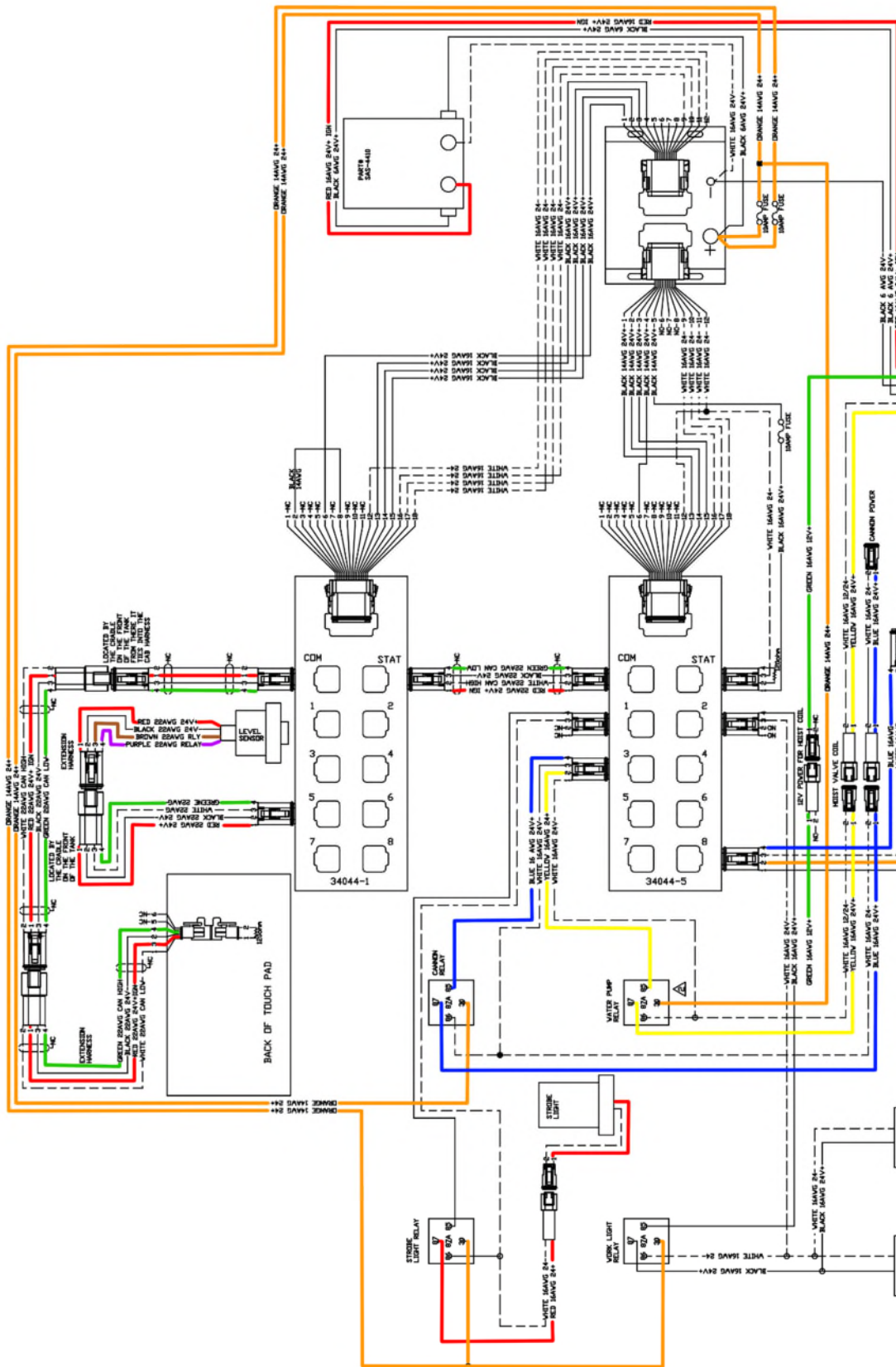

TITLE: 24V HOIST CIRCUIT
HYDRAULIC BOX

DATE: 5/24/23
REV 5

SIZE DRAWING NO 2187-1025
A3

SCALE: NTS | DRAWN BY: JS | SHEET 2 OF 9

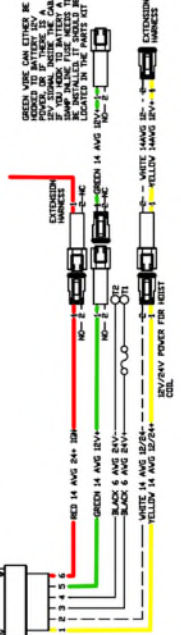

— Black
 - - - White

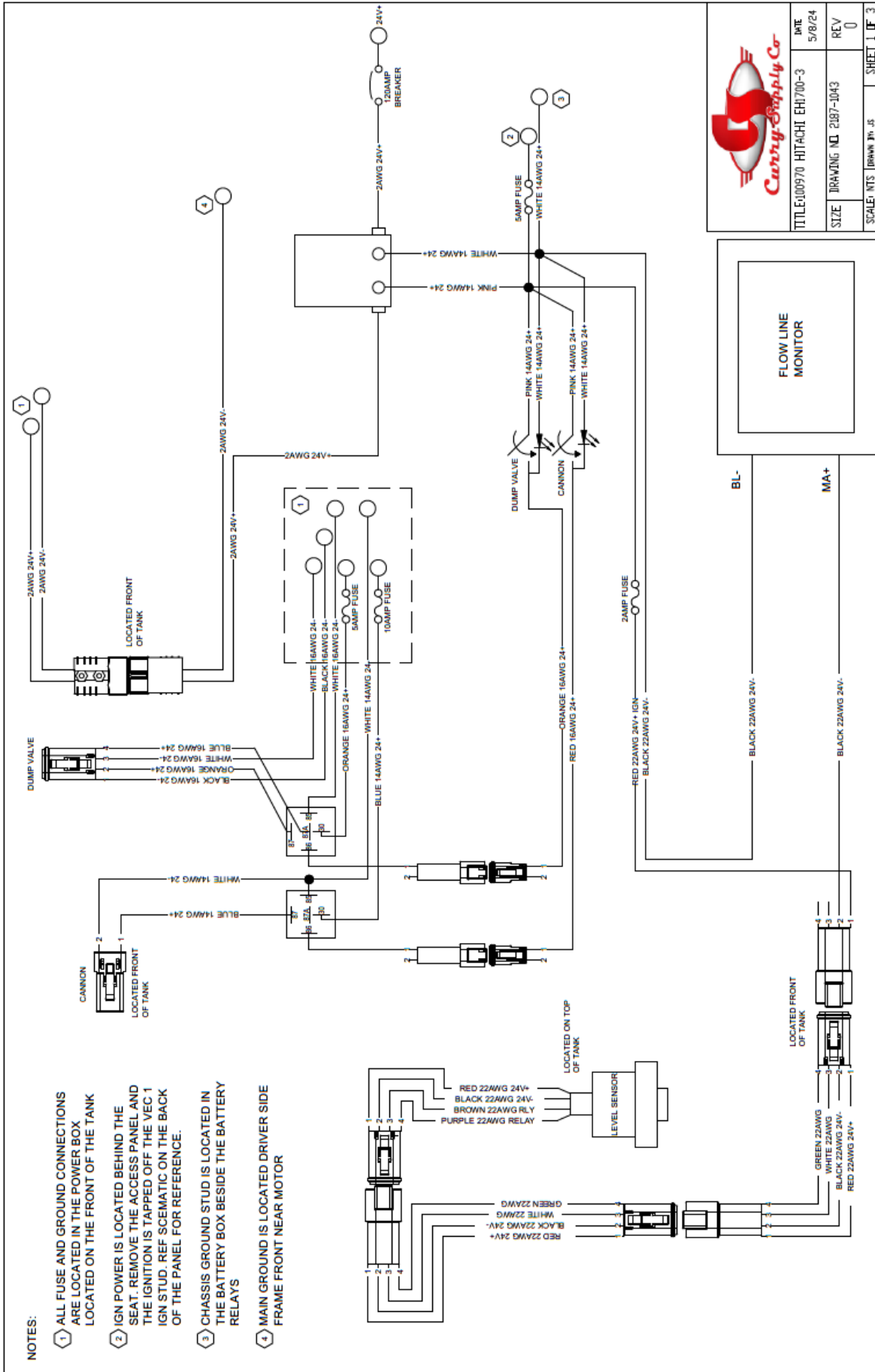

		TITLE: 00970 HITACHI EHI700-3	DATE: 5/8/24
		SIZE: DRAWING NO. 2187-1043	REV: 0
SCALE: NTS		DRAWN BY: JS	SHEET 1 OF 3

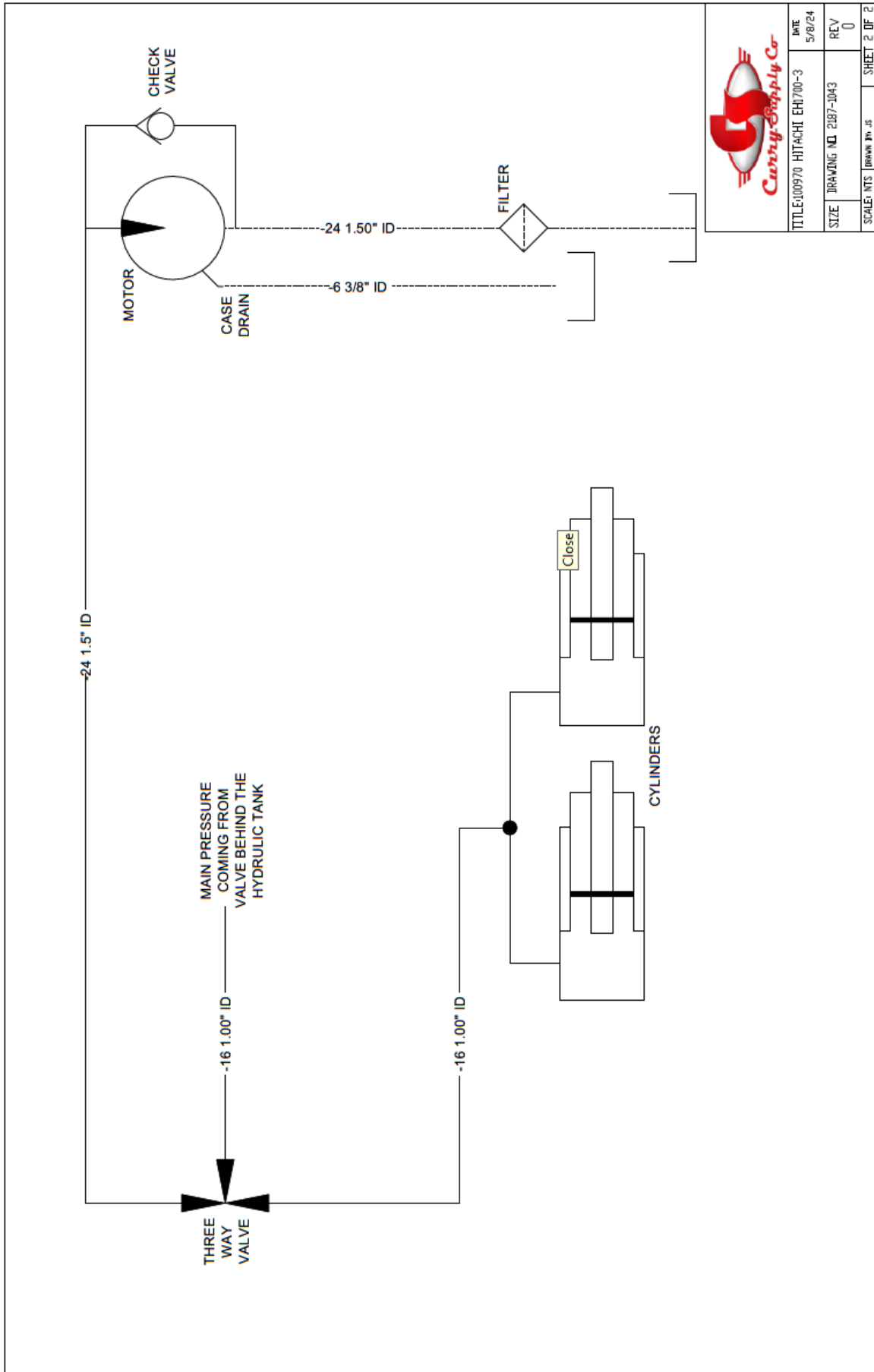

TITLE: 00970 HITACHI EH700-3		DATE: 5/8/24
SIZE: DRAWING NO. 2887-1043	REV: 0	SCALE: NTS
DRAWN BY: JS		SHEET 2 OF 2



SECTION 6

Troubleshooting

PROBLEM	POSSIBLE CAUSE	REMEDIES
No water pressure	Water pump not working correctly	Check hydraulic flow and pressure from hoist valve
	Truck not turned on	Start the truck ignition.
Water Pump not working	Blown fuse	Review the truck's manual for fuse location and replace blown fuse.
	Defective / Shorted Relay	
Spray head not spraying water	Spray head not open	Make sure spray head is open on tower or control dash.
	Water pump not turned on	Turn on water pump to get power to water pump.
Water Cannon will not function	Water Cannon Power not turned on	Turn on power by pulling up on water cannon power knob.
	Blown fuse	Review the truck's manual for fuse location and replace blown fuse.
Water Cannon will not move, moves intermittently	Debris blocking movement	Check for debris and clear obstruction.
	Monitor wires damaged	Inspect wires for connection or splicing, replace or contact customer service.



For technical help or parts, please have the model number available and call our customer service 800.345.2829



SECTION 7

Warranty & Proprietary Information

Curry Supply Company warrants products designed and manufactured by Curry Supply Company to be free from defects in material and workmanship under proper use and maintenance. Products must be installed and operated in accordance with Curry Supply's written instructions and capacities. All warranty periods will begin on the in-service date as defined in this document. This warranty shall cover the following Curry Supply Products:

	1 Year	2 Years	Variable
On Road Water / Flatbed / Crash Attenuator / Lube Skid			
Curry Manufactured Components		✓	
Paint Coverage on Curry Manufactured Parts	✓		
Parts	✓		
Repair Labor	✓		
Off Road / Dump / Industrial Carrier / Vacuum / Winch / Railroad			
Tank	✓		
Tank Exterior Paint Coverage	✓		
Parts	✓		
Repair Labor	✓		
Mechanics			
Body (Refer to Manufacture Warranty)			✓
Crane (Refer to Manufacture Warranty))			✓
Paint Coverage (Refer to Manufacture Warranty)			✓
Parts (Refer to Manufacture Warranty)			✓
Repair Labor (Refer to Manufacture Warranty)			✓
Lube			
Body (Refer to Manufacture Warranty)	✓		
Tanks (Refer to Manufacture Warranty)			✓
Parts	✓		
Repair Labor	✓		
Paint Coverage	✓		
Utility Lift			
Body (Refer to Manufacture Warranty)			✓
Lift (Axion)			✓
Parts	✓		
Repair Labor	✓		
Body Paint Coverage	✓		



Definitions

Curry Supply Manufactured Components/Structures – Includes any structural weldment or load bearing support structure manufactured by Curry Supply Company.

Rust Through on Curry Supply Components/Structures – Rust Through is defined as a hole in the metal caused by corrosion. Excluded is corrosion caused by external caustics, including but not limited to improper cleaning material, road salt and other chemicals left on the structure for extended periods of time.

Paint Coverage on Curry Supply Manufactured Parts – Curry Supply guarantees that exterior paint will not fail in terms of adhesion, blistering or unreasonable loss of color or gloss for a 1-year period. Excluded is damage such as chips, dents, scratches, tank interior coating, and corrosion due to caustic chemicals (eg. Brine Solution / Leachate) and dirt build-up. Regular cleaning and maintenance of the product to remove external factors is expected to keep this warranty in force.

Vendor Supplied Components/Structures – Products purchased by Curry Supply from outside vendors. These items shall be covered by the warranty offered by the respective manufacturer only. Curry Supply does not obligate itself to any such warranty.

Warranty Process

Curry Supply's obligation under this warranty is limited to, and the sole remedy for any such defect shall be, the repair and/or replacement (at Curry Supply's option) of the unaltered part and/or component in question. Curry Supply after-sales service personnel must be notified by telephone, email, or letter of any warranty applicable damage within fourteen (14) days of its occurrence. If possible, Curry Supply will ship the replacement part within 24-hours of notification by the most economical, yet expedient, means possible. Expedited freight delivery will be at the expense of the owner.

Warranty claims must be submitted and shall be processed in accordance with Curry Supply's established warranty claim procedure. Curry Supply after-sales service personnel must be contacted prior to any warranty claim. A return materials authorization (RMA) may be issued to the claiming party prior to the return of warranty parts. Parts returned without prior authorization will not be recognized for warranty consideration. All damaged parts must be returned to Curry Supply freight prepaid; freight collect returns will be refused. Freight reimbursement of returned parts will be considered as part of the warranty claim.

Warranty Repair

Warranty service will be performed by any Curry Supply factory, Curry Supply mobile technician, Curry Supply authorized service partner, or by the affected owner. At the time of requesting warranty service, Curry Supply after-sales service personnel will verify date of delivery of the product. The owner shall be obligated to pay for any overtime labor requested of the servicing company by the owner, any field service call charges, and any towing and/or transportation charges associated with moving the equipment to the designated repair/service provider.

All obligations of Curry Supply and its service providers shall be voided if someone other than an authorized Curry Supply provider performs other than routine maintenance service without prior written or verbal approval from Curry Supply. In the case repair work is performed on a Curry Supply-manufactured product, original Curry Supply parts must be used to keep the warranty in force. The warranty may also be voided if the product is modified or altered in any way not approved, in writing, by Curry Supply.

Warranty Limitations/Responsibilities

This warranty covers only defective material and workmanship. It does not cover depreciation or damage caused by normal wear and tear, accident, mishap, untrained operators, or improper or unintended use. The owner has the obligation of performing routine care and maintenance duties as stated in Curry Supply's written instructions, recommendations, and specifications. Any damage resulting from owner/operator failure to perform such duties shall void the coverage of this warranty. The owner will pay the cost of labor and supplies associated with routine maintenance.

The only remedies the owner has in connection with the breach or performance of any warranty on the Curry Supply product specified are those set above. In no event will Curry Supply, or any company affiliated with Curry Supply, be liable for business interruptions, costs of delay, or for any special, indirect, incidental, or consequential costs or damages. Such costs may include, but are not limited to, loss of time, loss of revenue, loss of use, wages, salaries, commissions, lodging, meals, towing, hydraulic fluid, or any other incidental cost.

All products purchased by Curry Supply from outside vendors shall be covered by the warranty offered by that respective manufacturer only. Curry Supply does not participate in, or obligate itself to, any such warranty.



Curry Supply reserves the right to make changes in design or improvement upon its products without imposing upon itself the same upon its products theretofore manufactured.

This warranty will apply to all Curry Supply manufactured components/structures and upfit workmanship shipped from Curry Supply's factory. The warranty is for the use of the original owner only and is not transferable without prior written permission from Curry Supply.

Curry Supply After-Sales Contact Information:

Phone: (800) 345-2829

Email: service@currysupply.com

Mailing Address: 1477 DeGol Industrial Drive, Hollidaysburg, PA 16648

THIS WARRANTY IS EXPRESSLY IN LIEU OF ANY OTHER WARRANTIES, EXPRESS OR IMPLIED, INCLUDING ANY WARRANTY OF MERCHANTABILITY OR FITNESS FOR A PARTICULAR PURPOSE. REMEDIES UNDER THIS WARRANTY ARE LIMITED TO THE PROVISION OF MATERIAL AND SERVICES, AS SPECIFIED HEREIN. CURRY SUPPLY COMPANY, IS NOT RESPONSIBLE FOR INCIDENTAL OR CONSEQUENTIAL DAMAGES.

EXCEPT AS STATED, THERE IS NO WARRANTY, EXPRESS OR IMPLIED, IN CONNECTION WITH THE DESIGN, MANUFACTURE, SALE OR USE OF THE MACHINERY, ACCESSORIES, EQUIPMENT AND PARTS SOLD BY CURRY SUPPLY CO. CURRY SUPPLY COMPANY'S LIABILITY ON ITS WARRANTY SHALL IN NO EVENT EXCEED THE COST OF THE ITEM OF SALE.

